

# IN Series HMI Installation Manual

## Part 1 General Note

- The communication interfaces of this series of HMI all support RS232, RS485, RS422 communication, which are composite communication ports. When downloading the project, please use the USB download cable, U disk interface to download.
- The power ground must be connected to make the HMI run correctly.
- The communication ground must be connected to make the HMI communicate correctly.

## Part 2 Safety Precautions

Notice following safety precautions at any moment when installing,wiring,operating,vindicate and examine.

### Installation

- Please setup the HMI according to this manual otherwise it may cause device damage.
- It's Forbid to uncover the product in the environment that has water vapor,Corrosive gas or combustible gas,otherwise it may cause short circuit or fire.

### Wiring

- Please connect the grounding terminal with class-3ground,otherwise it may cause short circuit or fire.
- this series HMI use 24-volt power supply.Any connection of non-standard power supply will lead to machine damage.

### Operation

- this series HMI need PISudio software to design project picture. HMI not designed may lead to run abnormally.
- Do not change wiring while the power is ON,otherwise it may cause short circuit or device damage.
- Please do not touch panel with sharp objects,otherwise it may lead to panel depressed,there by make HMI run abnormality.

### Maintenance

- It's forbidden to touch inside HMI,or else it may lead to short circuit or device damage.
- When power,it's forbidden to dismantle HMI panel,otherwise it may lead to short circuit or device damage.
- Do not touch connection terminal in 10 minutes of turning off power,otherwise residual voltage may lead to short circuit or device damage.
- When operating,exhaust vent should not be sealed,otherwise it may lead to failure easily.

### Communication

- Please connect to the communication wire according to this manual.
- The length of communication wire should meet the requirement.
- Use the correct ground loops in order to avoid abnormal communication.

## Part 3 Work Environment

The product must be placed in the pack box before installation,if not used for a while,in order to make the product accord with the warranty of our company and future maintenance, be sure to notice the following items when stored.

- Storage environment must be dry and dust-free.
- Storage ambient temperature must refer to "Specifications".
- Storage humidity must refer to "Specifications".
- Avoid corrosive gases and liquids in the storage environment.
- Avoid placing the product directly on the ground.

## Part 4 Basic Inspection

Please do following basic checking before using this series HMI.

### General

- Check if each screw is loose.
- The vent hole should be protected from oil, water and metal powder, and the chip powder of the drill should be prevented from falling into the HMI.
- If there are harmful gases or dust in the HMI operating environment, please take protective measures.

### Checking before installation (Unpowered)

- Please deal with connection division of wiring terminal insulated.
- Communication wiring should be correct, otherwise abnormal operation may occur.
- Check for foreign matter entering the interior of the HMI, especially for flammable substances and conductive materials such as screws, metal sheets, etc.
- Please regulate instrument to reduce electromagnetism interference.
- Check HMI supply voltage.

### Checking before running (powered)

- Check the status of the power indicator.
- Check if the communication between the HMI and the device is normal.
- If there is any abnormality in the HMI interface, please contact the manufacturer.

## Part 5 Packing List

Sequence number	Component	Quantity
1	this series HMI	1
2	HMI LED	4
3	Power terminal	1

## Part 6 Specifications

Module	IN1071 / IN1072 / IN1073
<b>Content</b>	
<b>Power voltage</b>	DC24V
<b>Power voltage range</b>	DC12V-DC28V
<b>Permissible instantaneous power failure time</b>	<5ms
<b>Power consumption</b>	<8W
<b>Operating ambient temperature</b>	-10°C~+55°C
<b>Storage ambient temperature</b>	-20°C~+70°C
<b>Operating ambient humidity</b>	10%~90%RH (Non-condensing)
<b>Storage ambient humidity</b>	10%~90%RH (Non-condensing)
<b>Vibration resistance</b>	Conforms to IEC61131-2 standard: Continuous vibration:10Hz~57Hz 0.0755mm,57Hz~150Hz 9.8m/s <sup>2</sup> Intermittent vibration:10Hz~57Hz 0.0035mm,57Hz~150Hz 4.9 m/s <sup>2</sup> in each X, Y, Z direction 10 times (80 miunuties)
<b>Corrosion resistance</b>	Avoid corrosive gas
<b>Cooling method</b>	Natural air cooling

### Part7 Parts And Function

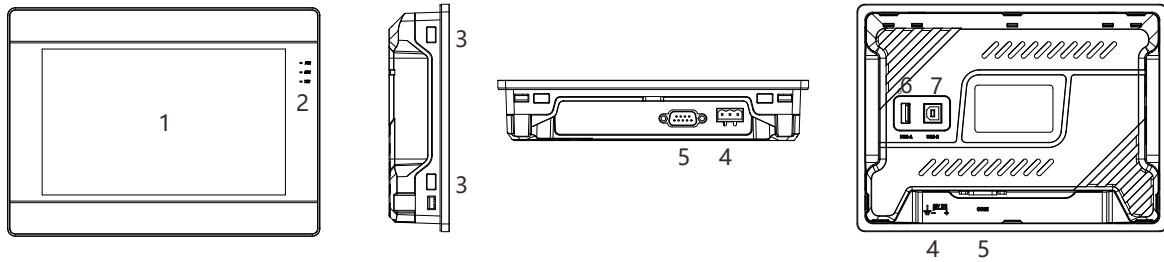

IN1071 Components description

1	LCD and touch screen	2	LED	3	Fixed buckle	4	Power terminal
5	COM	6	USB-A	7	USB-B		

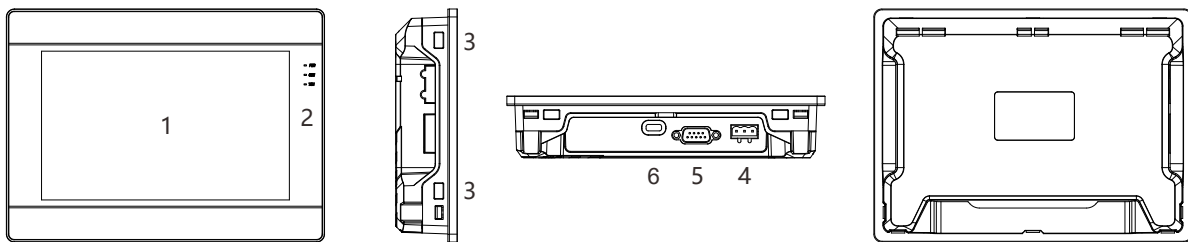

IN1072 / IN1073 Components description

1	LCD and touch screen	2	LED	3	Fixed buckle	4	Power terminal
5	COM	6	TYPE-C				

The power interface is defined as follows (from left to right):

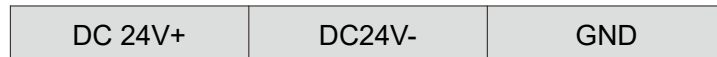
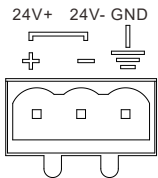

### Part8 The Size Of Product

Unit : mm , error range : ±0.5mm

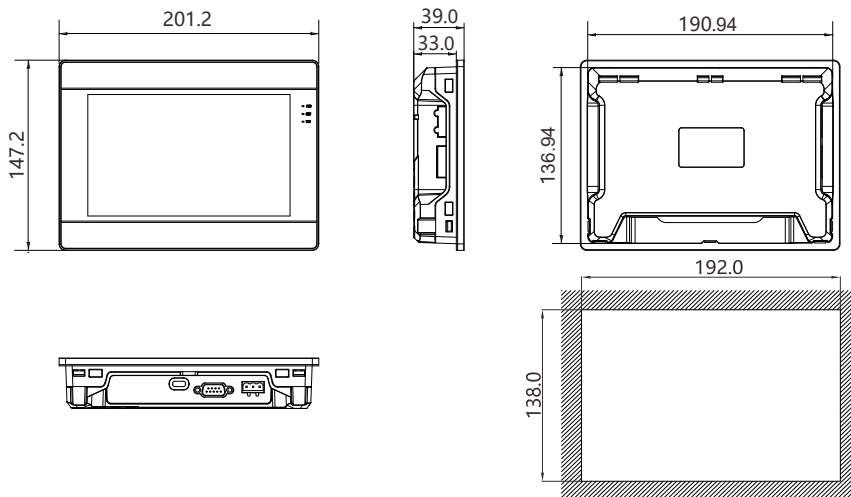

IN1071 /IN1072 /IN1073 installation size

## Part 9 Touch Screen Calibration

After starting HMI, keep on pressing top left corner of screen about 3 to 5 seconds, an interface will appear as following :

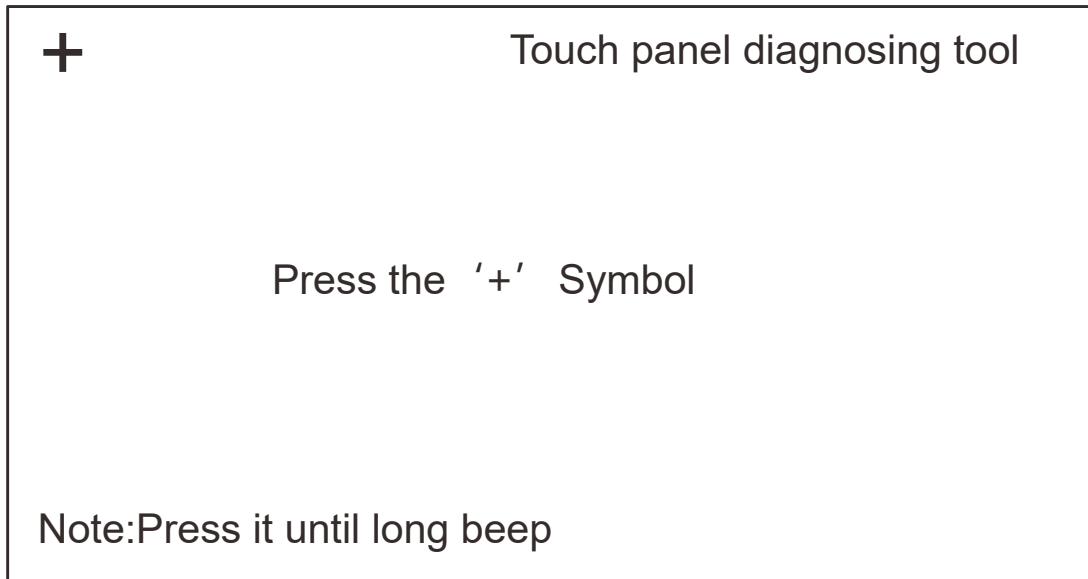

Click top left corner, top right corner, bottom right corner, bottom left corner and the center of '+' in turn and restart.

## Part 10 Parameters Setting

Keep on pressing top right corner of screen about 3 to 5 seconds,an interface will appear as following:

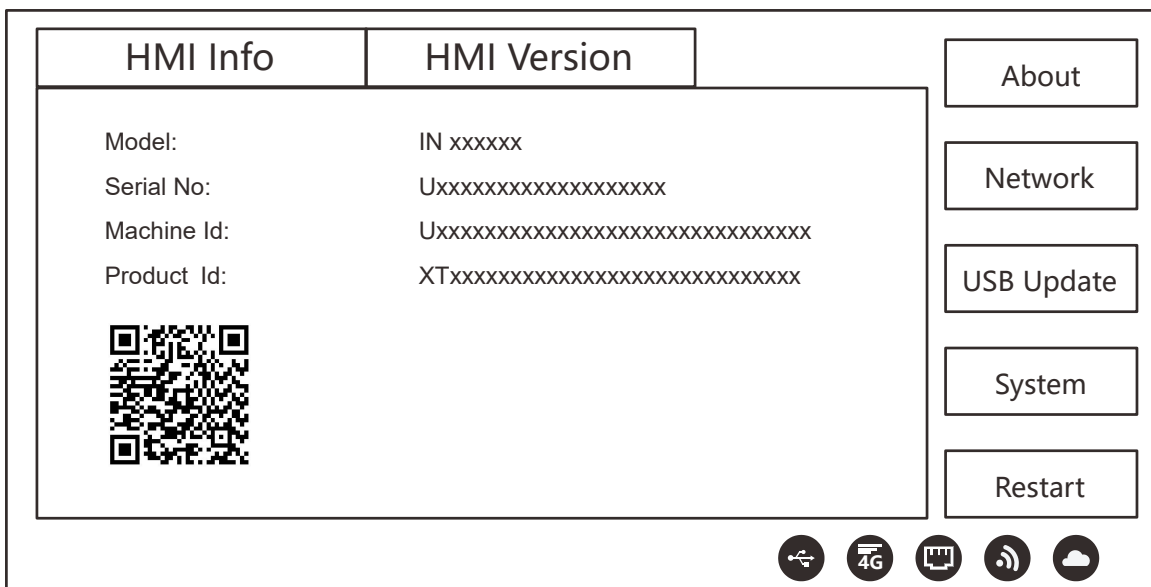

## Part 11 Product installation

### Notes:

- The installation direction must be in accordance,Otherwise it may lead to fault.
- In order to make circle effect greatly,adjacent objects and baffle should be kept on enough space when installation,otherwise it will cause bad cooling.
- Used in crust plane of Type 4X indoor grade.

### Installation steps:

- Make sure the waterproof gasket is cased,and then install HMI to the adaptive crust.
- Make sure the fixed piece screw is cased,and then hitch front cover screw to withstand inside control box .
- Please tight screws aptly and remember not too strength,otherwise it will lead to crustaceous damage. Torque:6.17lb-inch(0.7N-M)

## Part 12 Interface Definition

### IN1071 / IN1072 / IN1073 series interfaces

COM1 definition:

Pin	Definition	Pin	Definition
1	RS422 TX +/RS485 A +	2	RS232 RXD
3	RS232 TXD	5	GND
6	RS422 TX-/RS485 B-	8	RS422 RX-
9	RS422 RX+		

▲ Note:RS422 and RS485 can not be used in COM1 port of IN1071 / IN1072 / IN1073 series HMI at the same time.

## Notice

**The contents of this manual are subject to change without notice.**



**Wecon Technology Fu Zhou**

Address: 10 Building, E area, Fuzhou  
Software park, Fujian, P. R. China;  
Tel: 0086-591-87868869;  
Email: sales@we-con.com.cn;  
Web: www.we-con.com.cn/en;

WECON\_IN\_20230701