

VNZ200 Series

User Manual



Thank you for choosing VNZ200 series inverter.

Before installing, operating, maintaining or checking the driver, please read this manual carefully to give full play to the function of the driver and ensure the safety of users.

In this instruction manual, safety is divided into two categories: danger and attention. Please pay special attention to the "⚡Warning", "⚠Caution" symbols and related contents.

"⚡ WARNING" Incorrect or incorrect operation can cause hazards that may result in death or serious injury.

"⚠ Caution" of the harm caused by incorrect or wrong operation, which may lead to personal injury or failure of the drive and mechanical system. Depending on the situation, the precautions may also cause serious consequences.

The diagrams in this instruction manual are for the convenience of explanation, and may be slightly different from the production crystals. Due to product upgrades, there may be slight differences. Please refer to the actual product.

Please pay attention to hand this instruction manual to the end user and keep it proper for use in future inspection and maintenance.

If you have any questions, please contact the company or our agent in time, and we will serve you wholeheartedly.

1 Safety Precautions

Read this manual carefully before installation, operation, maintenance or inspection.

Precautions for safe operation in the manual are classified as "WARNING" or "CAUTION".



Indicates a potentially hazardous situation which, if not avoided, could result in personal injury or death.



Indicates a potentially critical situation that, if not identified, could result in minor or moderate personal injury and equipment damage.

This can also be used to alert on unsafe operations.

In some cases, even what is stated in the **caution** can lead to major accidents. So, in any case observe these important precautions.

Note:

**The steps taken to ensure proper operation.
Warning markings appear on the front cover of the drive.
Follow these guidelines when using the drive.**



- Risk of injury and electric shock.
- Read the manual and follow the safety instruction before use.
- Isolate from supply and wait 10 minutes before removing its cover.
- Ensure proper earth connection.
- Mount the inverter on a non-combustible surface.

2 Unpacking and inspection



- Do not install or operate any drive that is damaged or has outdated parts, otherwise there is a risk of injury.

When taking the drive out after unpacking, check the following items.

1. Check that there is no injury (damage or chip on the body) of the drive during transportation.
2. Check that there are instructions and warranty cards in the box.
3. Check the drive nameplate and confirm that it is the product you ordered.
4. Please confirm that the optional accessories you received are what you need, if you ordered optional accessories for the drive.

If you find a damaged drive or optional accessories, please contact your local dealer immediately.

3 Removal and Installation Warnings



The design, installation, commissioning and operation of the equipment must be carried out by trained and qualified professionals; during the work, all the regulations in "Warning" must be followed, otherwise serious personal injury or heavy property damage may be caused.

The input power cord is only allowed to be permanently connected, and the equipment must be grounded reliably.

Even if the drive is not in operation, the following terminals may still carry dangerous voltages:

- Power terminals R, S, T
- Connect the terminals U, V, W of the motor

After the power switch is turned off, you must wait for more than 10 minutes and the drive has been discharged before starting the installation work.

The minimum cross-sectional area of the grounding conductor is at least 10mm², or corresponding to the data in the table below, the maximum value of the two is required to be selected as the area of the grounding conductor:

Power line conductor cross-sectional area S mm² Ground conductor cross-sectional area.

$S \leq 6$	S
$16 < S \leq 35$	16
$35 < S$	$S/2$



Lift the cabinet by the base, do not hold the panel to lift when moving the drive, otherwise the main unit may fall, which may cause personal injury.

The driver should be installed on flame-retardant materials such as metal, away from heat sources and flammable objects to avoid fire.

When more than two drives are installed in a cabinet, a cooling fan should be installed and the air temperature should be controlled below 40 °C, otherwise overheating will cause fire or damage to the device.

VNZ200 Series User Manual

Chapter 1 Overview

1.1 Nameplate

Model:



VNZ200 - 3R7/5R5 G/P - 4

① ② ③ ④

No.	Identification	Description
①	VNZ200	Series name
②	3R7/5R5	3R7: 3.7kW 5R5: 5.5kW
③	G/P	G: Constant torque P: Variable torque
④	2/4	2: 1PH AC220V INPUT 4: 3PH AC380V INPUT

1.2 Specifications

Items		Specifications
Basic control functions	Control method	Open loop vector control (Without PG), V/F control
	Highest frequency	Vector control: 0 to 600 Hz V/F control: 0 to 320 0Hz
	Carrier frequency setting	0.5kHz to 16kHz The carrier frequency can be automatically adjusted according to the load characteristics.
	Input frequency resolution	Digital setting: 0.01Hz Analog setting: maximum frequency × 0.025%
	Starting torque	Model G: 0.5 Hz/150% (Without PG) P-type machine: 0.5 Hz/100%
	Speed range	1:100 (Without PG)
	Steady speed accuracy	± 0.5 % (Without PG)
	Overload capacity	G type machine: 150% rated current 60s; 180% rated current 3s. P type machine: 120% rated current 60s; 150% rated current 3s.
	Torque boost	Automatic torque boost; manual torque boost 0.1%-30.0%
	V/F curve	Three ways: linear type; multi-point type; N-th power V/F curve (1.2 power, 1.4 power, 1.6 power, 1.8 power, 2 power)
	V/F separation	2 ways: full separation, half separation
	Acceleration and deceleration curve	Linear or S-curve acceleration and deceleration methods. Four kinds of acceleration and deceleration time, the acceleration and deceleration time range is 0.0-6500.0s
	DC braking	DC braking frequency: 0.00Hz-maximum frequency Braking time: 0.0s-36.0s Braking current value: 0.0%-100.0%
	Jog control	Jog frequency range: 0.00Hz-50.00Hz. The jog acceleration and deceleration time is 0.0s-6500.0s.
	PLC, multi-speed operation	Realize up to 16-speed operation through built-in PLC or control terminals
	Built-in PID	Process control closed-loop control system can be easily realized.
	Automatic Voltage Adjustment (AVR)	When the grid voltage changes, it can automatically keep the output voltage constant.
	Overvoltage and overcurrent stall control	Automatically limit current and voltage during operation to prevent frequent overcurrent and overvoltage tripping
	Fast current limiting function	Minimize overcurrent faults and protect the normal operation of the inverter
Torque Limiting and Control	" Excavator " feature, which automatically limits the torque during operation to prevent frequent overcurrent tripping	

Personalization	Great performance	Asynchronous or synchronous motor control with high performance current vector control technology
	Instantaneous power failure	In the event of an instantaneous power failure, the voltage reduction is compensated by the load feedback energy, and the inverter continues to run for a short time.
	Fast current limiting	Avoid frequent overcurrent faults of the inverter
	Timing function	Timing control function: set the time range from 0.0 minutes to 6500.0 minutes
	Communication method	RS-485
Running	Run command channel	Operation panel given, control terminal given, serial communication port given. Switchable in a variety of ways
	Frequency source	Multiple frequency sources: digital given, analog voltage given, analog current given, serial port given. Switchable in a variety of ways
	Auxiliary frequency source	10 auxiliary frequency sources. Auxiliary frequency fine-tuning and frequency synthesis can be flexibly realized
	Input terminal	37KW and below: 4 digital input terminals; 1 analog input terminal, support 0-10V voltage input or 4-20mA current input (AVI) 45KW and above: 6 digital input terminals, one of which supports high-speed pulse input up to 100kHz (S3 optional); 2 analog input terminals, 1 only supports 0-10V voltage input (FIV), 1 support 0-10V voltage input or 4-20mA current input (FIC)
	Output terminal	37KW and below: 1 relay output terminal (RA, RC); 45KW and above: 1 digital output terminal (MO1) 1 relay output terminal (RA, RB, RC) 1 analog output terminal, support 0-20mA current output or 0-10V voltage output (FOV)
Keyboard display	LED display	Display parameters
	Key lock and function selection	Part or all of the keys can be locked, and the scope of action of some keys can be defined. to prevent misuse
	Protective function	Power-on motor short circuit detection, output phase loss protection, overcurrent protection, overvoltage protection, undervoltage protection, overheat protection, overload protection, etc.

Environment	Place of use	Indoor, no direct sunlight, no dust, corrosive gas, flammable gas, oil Fog, water vapor, dripping water or salt, etc.
	Altitude	Below 1000m (Above 1000m need to downshift)
	Ambient temperature	- 10 °C - + 40 °C (Ambient temperature is 40 °C - 50 °C, please downshift to use)
	Humidity	Less than 95%RH, no condensation
	Vibration	Less than 5.9m/s ² (0.6g)
	Storage temperature	- 20 °C - + 60 °C
	Protection class	IP20

1.3 Models

Inverter model	Input voltage	Rated output power (KW)	Rated input current (A)	Rated output current (A)	Applicable motor (KW)
VNZ200-0R4G -2	1PH AC 220V ±15%	0.4	5.4	2.5	0.4
VNZ200-0R75G -2		0.75	7.2	5.0	0.75
VNZ200-1R5G -2		1.5	10.0	7.0	1.5
VNZ200-2R2G -2		2.2	16	11	2.2
VNZ200-3R7G -2		3.7	24	16.5	3.7
VNZ200-0R4G -4	3PH AC 380V ±15%	0.4	3.4	1.2	0.4
VNZ200-0R75G -4		0.75	3.8	2.5	0.75
VNZ200-1R5G -4		1.5	5.0	3.7	1.5
VNZ200-2R2G -4		2.2	5.8	5.0	2.2
VNZ200-3R7G /5R5P-4		3.7 /5.5	10/15	9/13	3.7 /5.5
VNZ200-5R5G /7R5P-4		5.5 /7.5	15/20	13/27	5.5 /7.5
VNZ200-7R5G /11P-4		7.5 / 11	20/26	17/25	7.5/11
VNZ200-11G /15P-4		11/15	26/35	25/32	11/15
VNZ200 -15G/18.5P-4		15/18.5	3 5/38	32/37	15/18.5
VNZ200 -18.5G/22P-4		18.5/22	3 8/46	37/45	18.5/22
VNZ200-22G/30P-4		22/30	46/62	45/60	22/30
VNZ200-30G/37P-4		30/37	62/76	60/75	30/37
VNZ200-37G/45P-4		37/45	76/90	75/90	37/45
VNZ200-45G/55P-4		45/55	90/105	90/110	45/55
VNZ200-55G-4		55	105	110	55
VNZ200-75P-4		75	140	150	75
VNZ200-75G/90P-4		75/90	140/160	150/176	75/90
VNZ200-90G/110P-4		90/110	160/210	176/210	90/110
VNZ200-110G/132P-4		110/132	210/240	210/253	110/132
VNZ200-132G/160P-4		132/160	240/290	253/300	132/160
VNZ200-160G/185P-4	160/185	290/330	300/340	160/185	
VNZ200-185G/200P-4	185/200	330/370	340/380	185/200	
VNZ200-200G/220P-4	200/220	370/410	380/420	200/220	

VNZ200-220G/250P-4		220/250	410/460	420/470	220/250
VNZ200-250G/280P-4		250/280	460/500	470/520	250/280
VNZ200-280G/315P-4		280/315	500/580	520/600	280/315
VNZ200-315G/350P-4		315/350	580/620	600/640	315/350
VNZ200-350G/400P-4		350/400	620/670	640/690	350/400
VNZ200-400G/450P-4		400/450	670/790	690/790	400/450
VNZ200-450G/500P-4		450/500	790/835	790/860	450/500

1.4 The appearance and installation dimensions of the inverter

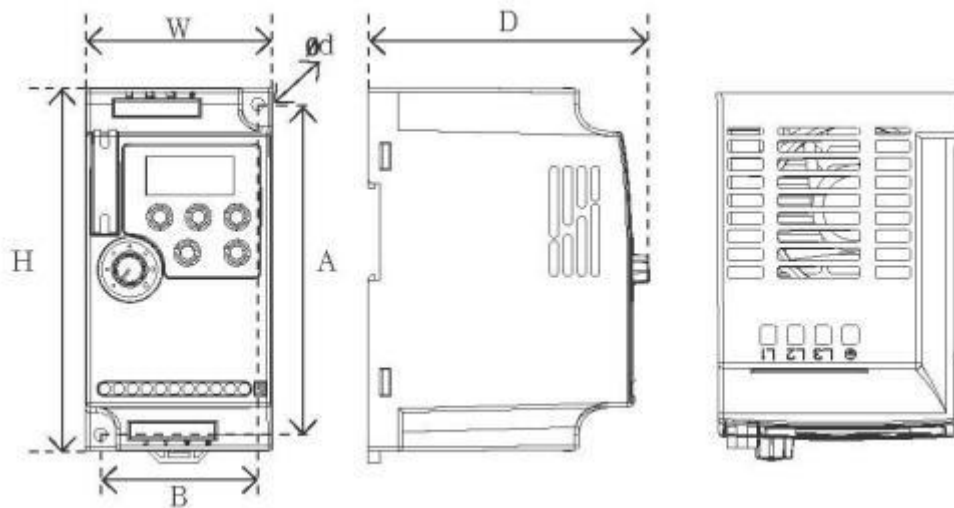

Note: Standard 35mm rail installation is supported below 5.5KW. Unit: mm

Model	Dimensions			Installation size		
	W	H	D	A	B	Ød
VNZ200-0R4G-2 VNZ200- 1R5G-2 VNZ200-0R4G-4 VNZ200-2R2G-4	72	142	112.2	130	61	4.5
VNZ200-2R2G-2 VNZ200-3R7G-2 VNZ200-3R7G/5R5P-4 VNZ200-5R5G/7R5P-4	85	180	116	167	72	5.5
VNZ200-7R5G/ 11P-4 VNZ200- 11G/ 15P-4	106	240	153	230	96	4.5
VNZ200- 15G/ 18.5P-4 VNZ200-22G/30P-4	151	332	165.5	318	137	7
VNZ200-30G/37P-4 VNZ200-37G/45P-4	217	400	201	385	202	7

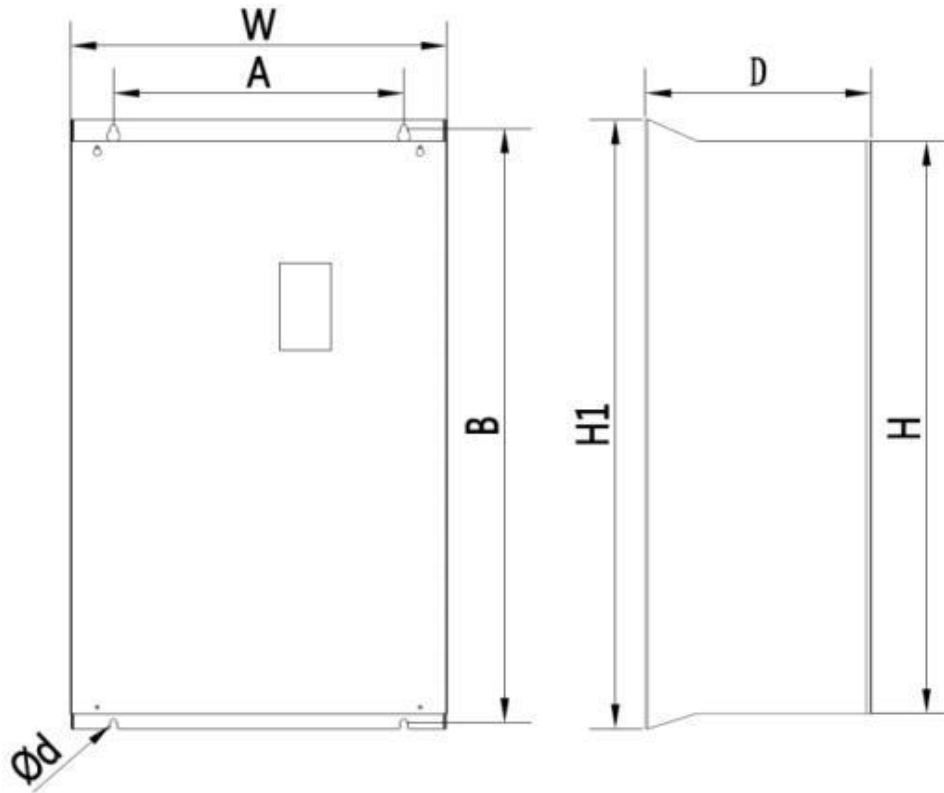

Unit: mm

Model	Dimensions				Installation size		
	W	H	H1	D	A	B	Ød
VNZ200-45G/55P-4 VNZ200-55G/75P-4	300	440	470	240	200	455	9
VNZ200-75G/90P-4 VNZ200-110G/132P-4	275	590	630	310	200	612	9
VNZ200-132G/160P-4 VNZ200-160G/185P-4	400	675	715	310	320	695	11
VNZ200-185G/200P-4 VNZ200-220G/250P-4	400	790	830	320	160+160	810	11
VNZ200-250G/280P-4 VNZ200-315G/350P-4	530	920	970	350	215+215	950	11
VNZ200-350G/400P-4 VNZ200-450G/500P-4	550	1120	1180	400	230+230	1150	13

Chapter 2 Wiring

2.1 Definition of Control Board Terminals

1. 37KW and below



2. 45KW and above

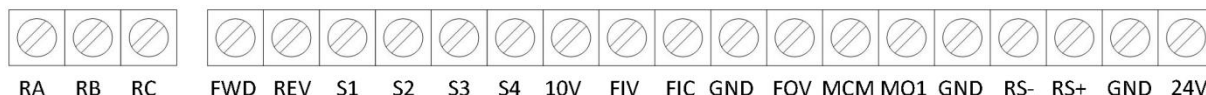

3. Control terminal description

Terminal name	Function Definition Description	Remarks
FWD	Forward command input terminal (multi-function input terminal)	Multi-function input terminal S1-S4, FWD, REV terminal can be Number P5.00-P5.05 specific set, set the terminal and valid when GND is closed
REV	Reverse command input terminal (multi-function input terminal)	
S1	fault reset	
S2	Multi-step speed command 1	
S3	Multi-step speed command 2 (high-speed pulse input)	
S4	Multi-step speed command 3	
FOV	Analog voltage output terminal	0-10V
10V	Power supply for frequency setting	
24V	Auxiliary power	
FIV	Analog voltage command input terminal	0-10V
FIC	Analog current command input terminal	0-20mA
GND	Input signal common terminal	
MCM	Optical coupling output common terminal	
MO1	Multifunctional optocoupler output contact	
RA	Relay output contact (normally open)	
RB	Relay wheel out contact (normally closed)	
RC	Common terminals of relay output contacts RA and RB	

2.2 Basic Wiring Diagramm

1. 0.75KW-37KW

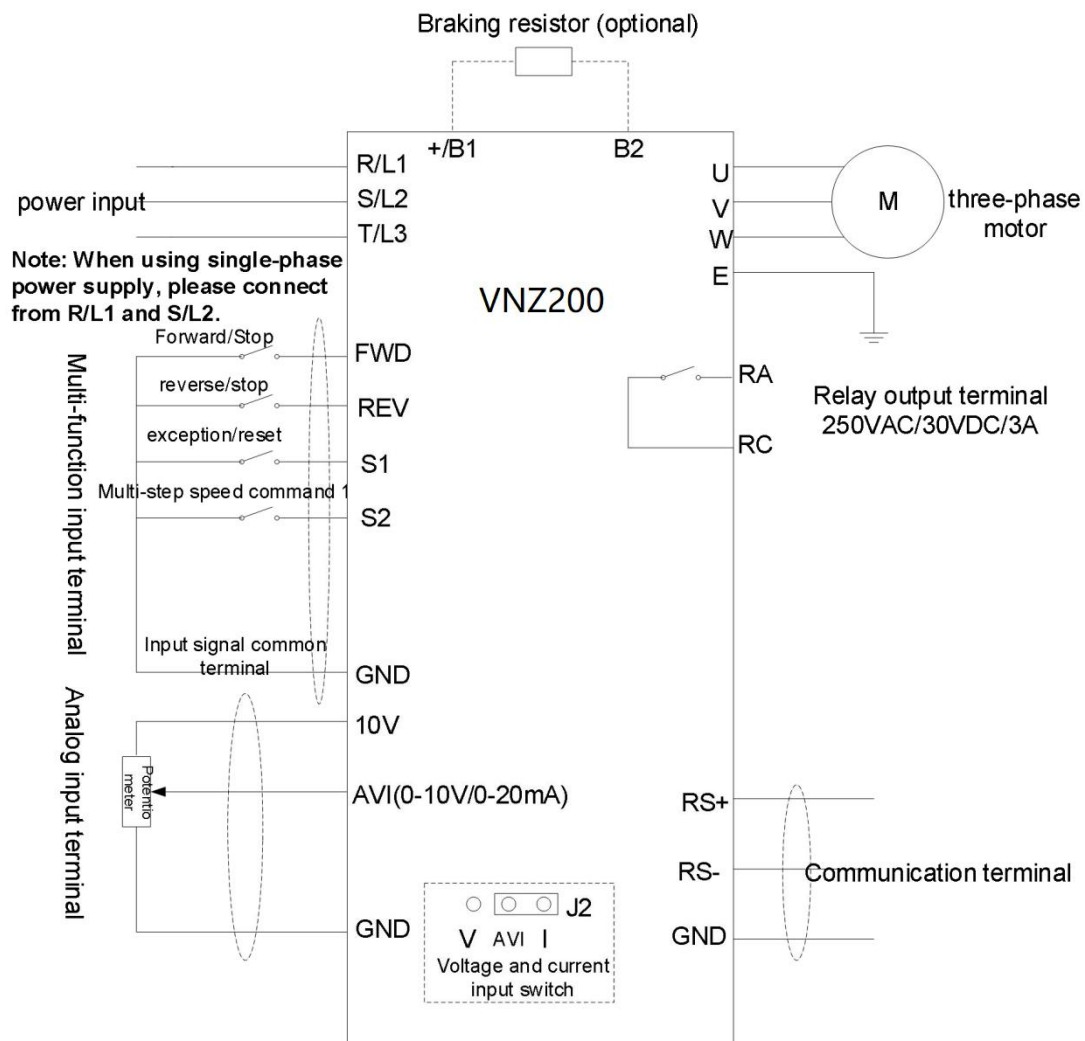

2. 45KW-450KW

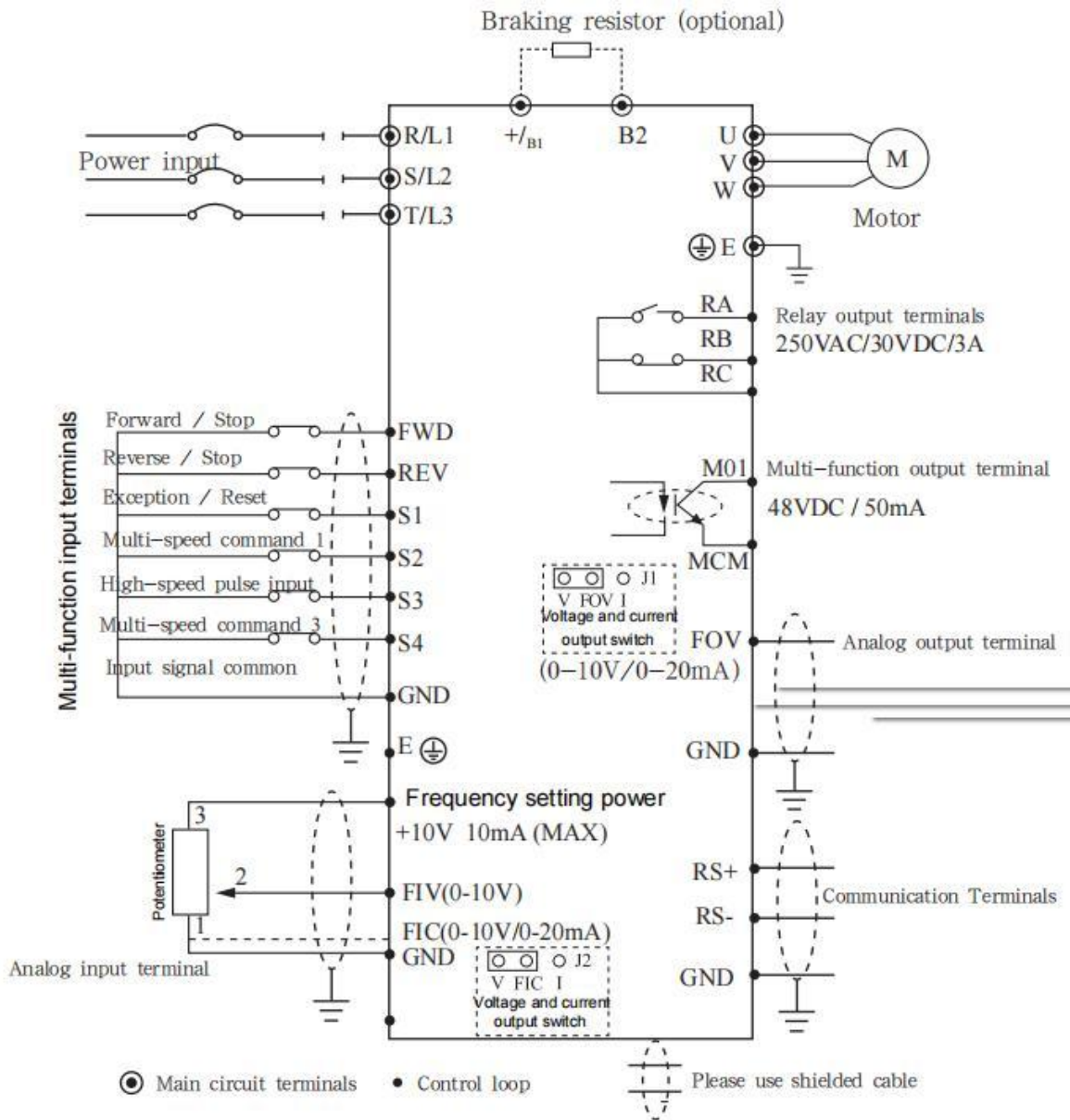

Chapter 3 Function Parameters

If PP.00 is set to a non-zero number, Parameter protection is enabled. You must enter the correct user password to enter the menu. To cancel the password protection function, enter with password and set PP.00 to 0.

Parameters menu the user customizes are not protected by password. Group P is the basic function Parameters, Group D is to monitor the function Parameters. The symbols in the function code.

"☆": The Parameter can be modified when the AC drive is in either stop or running state.

"★": The Parameter cannot be modified when the AC drive is in the running state.

"●": The Parameter is the actually measured value and cannot be modified.

"*": The Parameter is factory Parameter and can be set only by the manufacturer.

Standard Function Parameters

Function Code	Parameter Name	Setting Range	Default	Property
Group P0: Standard Function Parameters				
P0.00	G/P type display	1: G type (constant torque load) 2: P type (variable torque load, e.g. fan and pump)	Model dependent	★
P0.01	Control mode selection	0: Voltage/Frequency(V/F) control 1: Sensorless flux vector control (SFVC)	0	★
P0.02	Command source selection	0: Operation panel control (LED off) 1: Terminal control (LED on) 2: Communication control (LED blinking)	0	☆

Function Code	Parameter Name	Setting Range	Default	Property
P0.03	Frequency source superposition selection	One's digit: Selection of frequency source 0: Main frequency source X 1: Main and auxiliary calculation results 2: Switchover between X and Y 3: Switchover between X and main (X) & auxiliary(Y) calculation 4: Switchover between Y and main (X) & auxiliary(Y) calculation Ten's digit: X and Y calculation relationship 0: X+Y 1: X -Y 2: Maximum (X, Y) 3: Minimum (X, Y)	00	☆
P0.04	Main frequency source X selection	0: Digital setting (P01.0 preset frequency, can modify the UP/DOWN, non-retentive at power failure) 1: Digital setting (P0.10 preset frequency, can modify the UP/ DOWN, retentive at power failure) 2: FIV/keyboard potentiometer 3: FIC/AVI 4: Reserved 5: Pulse setting(S3) 6: Multistage instruction 7: Simple PLC 8: PID 9: Communications given	2	★
P0.05	Auxiliary frequency source Y selection	The same as P0.04 (Main frequency source X selection)	0	★
P0.06	Auxiliary frequency source superposition Y range selection	0: Relative to the maximum frequency 1: Relative to the main frequency source X	0	☆
P0.07	Auxiliary frequency source superposition Y range	0%-150%	100%	☆

Function Code	Parameter Name	Setting Range	Default	Property
P0.08	Acceleration time 1	0.00s-6500.0s	Model dependent	☆
P0.09	Deceleration time 1	0.00s-6500.0s	Model dependent	☆
P0.10	Frequency preset	0.00Hz-maximum frequency (P0.12)	50.00Hz	☆
P0.11	Running direction	0: Forward direction 1: Reverse direction	0	☆
P0.12	Maximum frequency	50.00Hz-320.00Hz	50.00Hz	★
P0.13	Upper limit frequency source	0: P0.12 1: FIV 2: FIC/AVI 3: Reserved 4: PULSE settings 5: Communication settings	0	★
P0.14	Upper limit frequency	Frequency lower limit P0.16 - Maximum frequency P0.12	50.00Hz	☆
P0.15	Upper limit frequency offset	0.00Hz-Maximum frequency P0.12	0.00Hz	☆
P0.16	Frequency lower limit	0.00Hz-Upper limit frequency P0.14	0.00Hz	☆
P0.17	Carrier frequency	1.0kHz-16.0kHz	Model dependent	☆
P0.18	Carrier frequency adjustment with temperature	0: No 1: Yes	1	☆
P0.19	Acceleration/Deceleration time unit	0: 1s 1: 0.1s 2: 0.01s	1	★
P0.21	Frequency offset of auxiliary frequency source for X and Y operation	0.00Hz-Maximum frequency P0.12	0.00Hz	☆
P0.22	Frequency reference	1: 0.1Hz 2: 0.01Hz	2	★

Function Code	Parameter Name	Setting Range	Default	Property
P0.23	Retentive of digital setting frequency upon power	0: Non-retentive 1: Retentive	0	☆
P0.24	Acceleration/Deceleration time base frequency	0: Maximum frequency (P0.12) 1: Set frequency 2: 100Hz	0	★
P0.25	Base frequency for UP/DOWN modification during running	0: Running frequency 1: Set frequency	0	★
P0.26	Binding command source to frequency source	Unit's digit: Binding operation panel command to frequency source 0: No binding 1: Frequency source by digital setting 2: FIV 3: FIC/AVI 4: Reserved 5: Pulse setting (S3) 6: Multi-reference 7: Simple PLC 8: PID 9: Communication setting Ten's digit: Binding terminal command to frequency source (0-9, same as unit's digit) Hundred's digit: Binding communication command to frequency source (0-9, same as unit's digit)	000	☆
P0.27	Communication type	0: Modbus	0	☆
Group P1: Start/Stop Control				
P1.00	Start mode	0: Start directly 1: Speed tracing and start 2: Pre-excitation start (Asynchronous motor)	0	☆

Function Code	Parameter Name	Setting Range	Default	Property
P1.01	Rotational speed tracking mode	0: Start with the frequency of input power failure 1: Start at zero speed 2: Start at the maximum frequency	0	★
P1.02	Rotational speed tracking speed	1-100	20	☆
P1.03	Startup frequency	0.00Hz-10.00Hz	0.00Hz	☆
P1.04	Startup frequency holding time	0.0s-100.0s	0.0s	★
P1.05	Startup DC braking current/ Pre-excited current	0%-100%	0%	★
P1.06	Startup DC braking time/ Pre-excited time	0.0s-100.0s	0.0s	★
P1.07	Acceleration/ Deceleration mode	0: Linear acceleration/ deceleration 1: S-curve acceleration/ deceleration A 2: S-curve acceleration/ deceleration B	0	★
P1.08	Time proportion of S-curve start	0.0%-(100.0%-P1.09)	30.0%	★
P1.09	Time proportion of S-curve end	0.0%-(100.0%-P1.08)	30.0%	★
P1.10	Stop mode	0: Decelerate to stop 1: Free stopping	0	☆
P1.11	Trigging frequency of DC braking at stop	0.00Hz-maximum frequency	0.00Hz	☆
P1.12	Waiting time of DC braking at stop	0.0s-100.0s	0.0s	☆
P1.13	The current of DC braking at stop	0%-100%	0%	☆
P1.14	The time of DC braking at stop	0.0s-100.0s	0.0s	☆
P1.15	Brake use rate	0%-100%	100%	☆

Function Code	Parameter Name	Setting Range	Default	Property
Group P2: Motor Parameters				
P2.00	Motor type selection	0: Common asynchronous motor 1: Variable frequency asynchronous motor	0	★
P2.01	Rated motor power	0.1kW-30.0kW	Model dependent	★
P2.02	Rated motor voltage	1V-2000V	Model dependent	★
P2.03	Rated motor current	0.01A-655.35A	Model dependent	★
P2.04	Rated motor frequency	0.01Hz-maximum frequency	Model dependent	★
P2.05	Rated motor rotational speed	1rpm-65535rpm	Model dependent	★
P2.06	Stator resistance (Asynchronous motor)	0.0012-65.535Q	Model dependent	★
P2.07	Rotor resistance (Asynchronous motor)	0.001Q-65.535Q	Model dependent	★
P2.08	Leakage inductive reactance (Asynchronous motor)	0.01mH-655.35mH	Model dependent	★
P2.09	Mutual inductive reactance	0.1mH-6553.5mH	Model dependent	★
P2.10	No-load current (Asynchronous motor)	0.01A-P2.03	Model dependent	★
P2.11-P2.36 Reserved				
P2.37	Tuning selection	0: No operation 1: Asynchronous motor static tuning 2: Asynchronous motor complete tuning	0	★
Group P3: Vector Control Parameters				
P3.00	Speed loop proportional gain 1	1-100	30	☆

Function Code	Parameter Name	Setting Range	Default	Property
P3.01	Speed loop integral time 1	0.01s-10.00s	0.50s	☆
P3.02	Switchover frequency 1	0.00-P3.05	5.00Hz	☆
P3.03	Speed loop	1-100	20	☆
P3.04	Speed loop integral time 2	0.01s-10.00s	1.00s	☆
P3.05	Switchover frequency 2	P3.02-maximum output frequency	10.00Hz	☆
P3.06	Vector control slip gain	50%-200%	100%	☆
P3.07	Time constant of speed loop filter	0.000s-0.100s	0.000s	☆
P3.08	Vector control over-excitation gain	0-200	64	☆
P3.09	Torque upper limit source in speed control mode	0: P3.10 1: FIV 2: FIC/AVI 3: Reserved 4: Pulse setting 5: Communication setting 6: MIN (FIV, FIC) 7: MAX (FIV, FIC)	0	☆
P3.10	Digital setting of torque upper limit in speed control mode	0.0%-200.0%	150.0%	☆
P3.13	Excitation adjustment proportional gain	0-60000	2000	☆
P3.14	Excitation adjustment	0-60000	1300	☆
P3.15	Torque adjustment proportional gain	0-60000	2000	☆
P3.16	Torque adjustment	0-60000	1300	☆

Function Code	Parameter Name	Setting Range	Default	Property
P3.17	Speed loop	Unit's digit: integral separation	0	☆
P3.18 Reserved				
P3.19 Reserved				
P3.20 Reserved				
P3.21 Reserved				
P3.22 Reserved				
Group P4: V/F Control Parameters				
P4.00	V/F curve setting	0: Linear V/F 1: Multi-point V/F 2: Square V/F 3: 1.2-power V/F 4: 1.4-power V/F 6: 1.6-power V/F 8: 1.8-power V/F 9: Reserved 10: V/F complete separation 11: V/F half separation	0	★
P4.01	Torque boost	0.0%: (Automatic torque boost) 0.1%-30.0%	Model dependent	☆
P4.02	Cut-off frequency of torque boost	0.00Hz-maximum output frequency	10.00Hz	★
P4.03	Multi-point V/F	0.00Hz-P4.05	0.00Hz	★
P4.04	Multi-point V/F	0.0%-100.0%	0.0%	★
P4.05	Multi-point V/F	P4.03-P4.07	0.00Hz	★
P4.06	Multi-point V/F	0.0%-100.0%	0.0%	★
P4.07	Multi-point V/F	P4.05-rated motor frequency (P1.04)	0.00Hz	★
P4.08	Multi-point V/F	0.0%-100.0%	0.0%	★
P4.09	V/F slip compensation gain	0.0%-200.0%	0.0%	☆
P4.10	V/F over-excitation gain	0-200	10	☆

Function Code	Parameter Name	Setting Range	Default	Property
P4.11	V/F oscillation suppression gain	0-100	Model dependent	☆
P4.13	Voltage source for V/F separation	0: digital setting (P4.14) 1: FIV 2: FIC 3: Reserved 4: PULSE setting(S3) 5: Multi-reference 6: Simple PLC 7: PID 8: Communication setting 100.0% corresponds to the rated motor voltage.	0	☆
P4.14	Voltage digital setting for V/F separation	0V-rated motor voltage	0V	☆
P4.15	Voltage rising time of V/F separation	0.0s-1000.0s It indicates the time for the voltage rising from 0 V to rated motor voltage.	0.0s	☆
P4.16	Voltage decline time of V/F separation	0.0s-1000.0s It indicates the time for the voltage to decline from rated motor voltage to 0 V.	0.0s	☆

Function Code	Parameter Name	Setting Range	Default	Property
Group P5: Input Terminals				
P5.00	FWD function selection	0: No function 1: Forward RUN(FWD)	1	★
P5.01	REV function selection	2: Reverse RUN(REV) 3: Three-line control 4: Forward JOG(FJOG) 5: Reverse JOG(RJOG) 6: Terminal UP 7: Terminal DOWN	2	★
P5.02	S1 function selection	8: Coast to stop 9: Reset Faults 10: RUN pause 11: Normally open (NO) input of external fault 12: Multi-reference terminal 1 13: Multi-reference terminal 2 14: Multi-reference terminal 3 15: Multi-reference terminal 4 16: Terminal 1 for acceleration/ deceleration time selection 17: Terminal 2 for acceleration/ deceleration time selection	9	★
P5.03	S2 function selection	18: Frequency source Switchover 19: UP and DOWN setting clear (terminal, operation panel) 20: Command source switchover terminal 1 21: Acceleration/Deceleration prohibited 22: PID pause 23: PLC status reset 24: Swing pause 25: Counter input 26: Counter reset 27: Length count input 28: Length reset 29: Torque control prohibited 30: Pulse input (Enabled only for S3) 31: Reserved 32: Immediate DC braking 33: Normally closed (NC) input of external fault	9	★

Function Code	Parameter Name	Setting Range	Default	Property
P5.04	S3 function selection	34: Frequency modification forbidden 35: Reverse PID action direction	0	★
P5.05	S4 function selection	36: External STOP terminal 1 37: Command source switchover terminal 2 38: PID integral pause 39: Switchover between main frequency source X and preset frequency 40: Switchover between auxiliary frequency source Y and preset frequency 41: Motor selection terminal 1 42: Motor selection terminal 2 43: PID Parameter switchover 44: Reserved 45: Reserved 46: Speed control/Torque control switchover 47: Emergency stop 48: External STOP terminal 2 49: Deceleration DC braking 50: Clear the current running time 51-59: Reserved	0	★
P5.10	S filter time	0.000s-1.000s	0.010s	☆
P5.11	Terminal command mode	0: Two-line mode 1 1: Two-line mode 2 2: Three-line mode 1 3: Three-line mode 2	0	★
P5.12	Terminal UP/ DOWN rate	0.001Hz/s-65.535Hz/s	1.00Hz/s	☆
P5.13	Fl curve 1 minimum input	0.00V-P5.15	0.00V	☆
P5.14	Corresponding setting of Fl curve 1 minimum input	-100.0%~+100.0%	0.0%	☆
P5.15	Fl curve 1 maximum input	P5.13~+10.00V	10.00V	☆

Function Code	Parameter Name	Setting Range	Default	Property
P5.16	Corresponding setting of Fl curve 1 maximum input	-100.0%~+100.0%	100.0%	☆
P5.17	Curve 1 filter time	0.00s-10.00s	0.10s	☆
P5.18	Fl curve 2 minimum input	0.00V-P5.20	0.00V	☆
P5.19	Corresponding setting of Fl curve 2 minimum input	-100.0%~+100.0%	0.0%	☆
P5.20	Fl curve 2 maximum input	P5.18~+10.00V	10.00V	☆
P5.21	Corresponding setting of Fl curve 2 maximum input	-100.0%~+100.0%	100.0%	☆
P5.22	Fl curve 2 filter time	0.00s-10.00s	0.10s	☆
P5.23	Fl curve 3 minimum input	-10.00V-P5.25	0.3V	☆
P5.24	Corresponding setting of Fl curve 3 minimum input	-100.0%~+100.0%	0.0%	☆
P5.25	Fl curve 3 maximum input	P5.23~+10.00V	10.00V	☆
P5.26	Corresponding setting of Fl curve 3 maximum input	-100.0%~+100.0%	100.0%	☆
P5.27	Curve 3 filter time	0.00s-10.00s	0.10s	☆
P5.28	PULSE minimum input	0.00kHz-P5.30	0.00kHz	☆
P5.29	Corresponding setting of pulse minimum input	-100.0%-100.0%	0.0%	☆
P5.30	PULSE maximum input	P5.28-100.00kHz	50.00kHz	☆
P5.31	Corresponding setting of pulse maximum input	-100.0%-100.0%	100.0%	☆

Function Code	Parameter Name	Setting Range	Default	Property
P5.32	PULSE filter time	0.00s-10.00s	0.10s	☆
P5.33	FI curve selection	Unit's digit: FIV curve selection 1: Curve 1(2 points, see P5.13-P5.16) 2: Curve 2(2 points, see P5.18-P5.21) 3: Curve 3(2 points, see P5.23-P5.26) 4: Curve 4(4 points, see C6.00-C6.07) 5: Curve 5(4 points, see C6.08-C6.15) Ten's digit: FIC curve selection (1-5, same as FIV) Hundred's digit: FIA curve selection (1-5, same as FIV)	321	☆
P5.34	Setting for FI less than minimum input	Unit's digit: Setting for FIV less than minimum input 0: Minimum value 1: 0.0% Ten's digit: Setting for FIC less than minimum input (0-1, same as FIV) Hundred's digit: Setting for FIA less than minimum input (0-1, same as FIV)	000	☆
P5.35	FWD delay time	0.0s-3600.0s	0.0s	★
P5.36	REV delay time	0.0s-3600.0s	0.0s	★
P5.37	S1 delay time	0.0s-3600.0s	0.0s	★
P5.38	S valid mode selection 1	0: High level valid 1: Low level valid Unit's digit: FWD Ten's digit: REV Hundred's digit: S1 Thousand's digit: S2 Ten thousand's digit: S3	00000	★
P5.39	S valid mode selection 2	0: High level valid 1: Low level valid Unit's digit: S4	0	★
Group P6: Output Terminals				
P6.00	M01 terminal output mode	1: Switch signal output(M01)	0	☆

Function Code	Parameter Name	Setting Range	Default	Property
P6.01	M01 function	0: No output 1: AC drive running 2: Fault output (stop) 3: Frequency-level detection FDT1 output 4: Frequency reached 5: Zero-speed running (no output at stop) 6: Motor overload pre-warning 7: AC drive overload pre-warning 8: Set count value Reached 9: Designated count value reached 10: Length reached 11: PLC cycle complete 12: Accumulative running time reached 13: Frequency limited 14: Torque limited 15: Ready for RUN 16: FIV>FIC 17: Frequency upper limit reached 18: Frequency lower limit reached (no output at stop) 19: Under voltage state output 20: Communication setting 21: Reserved 22: Reserved 23: Zero-speed running 2 (having output at stop) 24: Accumulative power-on time reached 25: Frequency level detection FDT2 output 26: Frequency 1 reached 27: Frequency 2 reached 28: Current 1 reached 29: Current 2 reached 30: Timing reached 31: FIV input limit exceeded 32: Load becoming 0 33: Reverse running 34: Zero current state 35: Module temperature reached 36: Software current limit exceeded	0	☆

Function Code	Parameter Name	Setting Range	Default	Property
P6.02	Relay output function (RA-RC/RA-RB-RC)	37: Frequency lower limit reached (having output at stop) 38: Alarm output 39: Reserved 40: Current running time reached	2	☆
P6.07	FOV function selection	0: Running frequency 1: Set frequency	0	☆
P6.08	Reserved	2: Output current 3: Output torque 4: Output power 5: Output voltage 6: Pulse input (100.0% for 100.0kHz) 7: FIV 8: FIC 9: Reserved 10: Length 11: Count value 12: Communication setting 13: Motor rotational speed 14: Output current (100.0% for 1000.0A) 15: Output voltage (100.0% for 1000.0V) 16: Reserved	-	-
P6.09	Reserved			
P6.10	FOV offset coefficient	-100.0%~+100.0%	0.0%	☆
P6.11	FOV gain	-10.00~+10.00	1.00	☆
P6.12	Reserved			
P6.13	Reserved			
P6.17	M01 output delay time	0.0s~3600.0s	0.0s	☆
P6.18	RA-RC/RA-RB-RC output delay time	0.0s~3600.0s	0.0s	☆
P6.19	Reserved			
P6.20	Reserved			
P6.21	Reserved			
P6.22	Output terminal valid mode selection	0: Positive logic 1: Negative logic Unit's digit: M01 Ten's digit: RA-RB-RC	00	☆

Function Code	Parameter Name	Setting Range	Default	Property
Group P7: Operation Panel and Display				
P7.00	Output power correction factor	0.0-200.0	100.0	☆
P7.01	JOG Function selection	0: Disabled 1: Switchover between keypad control and remote command control (terminal or communication) 2: Switchover between forward rotation and reverse rotation 3: Forward JOG 4: Reverse JOG 5: Menu mode switching		★
P7.02	STOP/RESET key function	0: STOP/RESET key enabled only in operation panel control 1: STOP/RESET key enabled in any operation mode	1	☆
P7.03	LED display running Parameters 1	0000-FFFF Bit00: Running frequency 1 (Hz) Bit01: Set frequency (Hz) Bit02: Bus voltage (V) Bit03: Output voltage(V) Bit04: Output current (A) Bit05: Output power(kW) Bit06: Output torque (%) Bit07: S input status Bit08: M01 output status Bit09: FIV voltage (V) Bit10: FIC voltage(V) Bit11: Reserved Bit12: Count value Bit13: Length value Bit14: Load speed display Bit15: PID setting	1F	☆

Function Code	Parameter Name	Setting Range	Default	Property
P7.04	LED display running parameters 2	0000-FFFF Bit00: PID feedback Bit01: PLC stage Bit02: Pulse setting frequency(kHz) Bit03: Running frequency 2 (Hz) Bit04: Remaining running time Bit05: FIV voltage before correction (V) Bit06: FIC voltage before correction (V) Bit07: Reserved Bit08: Linear speed Bit09: Current power-on time (Hour) Bit10: Current running time (Min) Bit11: Pulse setting frequency (Hz) Bit12: Communication setting value Bit13: Reserved Bit14: Main frequency X display (Hz) Bit15: Auxiliary frequency Y display (Hz)	0	☆
P7.05	LED display stop parameters	0000-FFFF Bit00: Set frequency (Hz) Bit01: Bus voltage (V) Bit02: S input status Bit03: M01 output status Bit04: FIV voltage(V) Bit05: FIC voltage(V) Bit06: Reserved Bit07: Count value Bit08: Length value Bit09: PLC stage Bit10: Load speed Bit11: PID setting Bit12: Pulse setting frequency(kHz) Bit13: PID feedback value	33	☆
P7.06	Load speed display coefficient	0.0001-6.5000	1.0000	☆
P7.07	Heatsink temperature of inverter	0.0°C-150.0°C	-	-
P7.08	Temporary	0.0°C-150.0°C	-	-
P7.09	Accumulative running	0h-65535h	-	-
P7.10	Reserved			
P7.11	Software version	-	-	-

P7.12	Numbers of decimal places for load speed display	0: 0 decimal place 1: 1 decimal place 2: 2 decimal places 3: 3 decimal places	1	☆
P7.13	Accumulative	0h-65535h	-	-
P7.14	Accumulative	0kW-65535kWh	-	-
Group P8: Auxiliary Functions				
P8.00	JOG running	0.00Hz-maximum frequency	2.00Hz	☆
P8.01	JOG acceleration	0.0s-6500.0s	20.0s	☆
P8.02	JOG deceleration time	0.0s-6500.0s	20.0s	☆
P8.03	Acceleration time 2	0.0s-6500.0s	Model dependent	☆
P8.04	Deceleration time 2	0.0s-6500.0s	Model dependent	☆
P8.05	Acceleration time 3	0.0s-6500.0s	Model dependent	☆
P8.06	Deceleration time 3	0.0s-6500.0s	Model dependent	☆
P8.07	Acceleration time 4	0.0s-6500.0s	Model dependent	☆
P8.08	Deceleration time 4	0.0s-6500.0s	Model dependent	☆
P8.09	Jump frequency 1	0.00Hz-maximum frequency	0.00Hz	☆

Function Code	Parameter Name	Setting Range	Default	Property
P8.10	Jump frequency 2	0.00Hz-maximum frequency	0.00Hz	☆
P8.11	Frequency jump amplitude	0.00Hz-maximum frequency	0.01Hz	☆
P8.12	Forward/Reverse rotation dead-zone	0.0s-3000.0s	0.0s	☆
P8.13	Reverse control	0: Enabled 1: Disabled	0	☆
P8.14	Running mode when set frequency lower than frequency lower limit	0: Run at frequency lower limit 1: Stop 2: Run at zero speed	0	☆
P8.15	Droop control	0.00Hz-10.00Hz	0.00Hz	☆
P8.16	Accumulative power-on time threshold	0h-65000h	0h	☆
P8.17	Accumulative running time threshold	0h-65000h	0h	☆
P8.18	Startup protection	0: No 1: Yes	0	☆
P8.19	Frequency detection value (FDT1)	0.00Hz-maximum frequency	50.00Hz	☆
P8.20	Frequency detection hysteresis (FDT1)	0.0%-100.0% (FDT1 level)	5.0%	☆
P8.21	Detection range of frequency reached	0.0%-100.0% (maximum frequency)	0.0%	☆
P8.22	Jump frequency during acceleration/ deceleration	0: Disabled 1: Enabled	0	☆
P8.25	Frequency switchover point between acceleration time 1 and acceleration time 2	0.00Hz-maximum frequency	0.00Hz	☆

Function Code	Parameter Name	Setting Range	Default	Property
P8.26	Frequency switchover point between deceleration time 1 and deceleration time 2	0.00Hz-maximum frequency	0.00Hz	☆
P8.27	Terminal JOG preferred	0: Disabled 1: Enabled	0	☆
P8.28	Frequency detection value (FDT2)	0.00Hz-maximum frequency	50.00Hz	☆
P8.29	Frequency detection hysteresis (FDT2)	0.0%-100.0% (FDT2 level)	5.0%	☆
P8.30	Any frequency reaching detection value 1	0.00Hz-maximum frequency	50.00Hz	☆
P8.31	Any frequency reaching detection amplitude 1	0.0%-100.0% (maximum frequency)	0.0%	☆
P8.32	Any frequency reaching detection value 2	0.00Hz-maximum frequency	50.00Hz	☆
P8.33	Any frequency reaching detection amplitude 2	0.0%-100.0% (maximum frequency)	0.0%	☆
P8.34	Zero current detection level	0.0%-300.0% 100.0% for rated motor current	5.0%	☆
P8.35	Zero current detection delay time	0.01s-600.00s	0.10s	☆
P8.36	Output over current threshold	0.0% (no detection) 0.1%-300.0% (rated motor current)	200.0%	☆
P8.37	Output over current detection delay time	0.00s-600.00s	0.00s	☆

Function Code	Parameter Name	Setting Range	Default	Property
P8.38	Any current reaching 1	0.0%-300.0% (rated motor current)	100.0%	☆
P8.39	Any current reaching 1 amplitude	0.0%-300.0% (rated motor current)	0.0%	☆
P8.40	Any current reaching 2	0.0%-300.0% (rated motor current)	100.0%	☆
P8.41	Any current reaching 2 amplitudes	0.0%-300.0% (rated motor current)	0.0%	☆
P8.42	Timing function	0: Disabled 1: Enabled	0	☆
P8.43	Timing duration source	0: P8.44 1: FIV 2: FIC 3: Reserved 100% of analog input corresponds to the value of P8.44	0	☆
P8.44	Timing duration	0.0Min-6500.0Min	0.0Min	☆
P8.45	FIV input voltage lower limit	0.00V-P8.46	3.10V	☆
P8.46	FIV input voltage upper limit	P8.45-10.00V	6.80V	☆
P8.47	Module temperature threshold	0°C-150°C	100°C	☆
P8.48	Cooling fan control	0: Fan working during running 1: Fan working continuously	0	☆
P8.49	Wakeup frequency	Dormant frequency (P8.51) -maximum frequency (P0.12)	0.00Hz	☆
P8.50	Wakeup delay time	0.0s-6500.0s	0.0s	☆
P8.51	Dormant frequency	0.00Hz-wakeup frequency (P8.49)	0.00Hz	☆
P8.52	Dormant delay time	0.0s-6500.0s	0.0s	☆
P8.53	Current running time reached	0.0Min-6500.0Min	0.0Min	★

Function Code	Parameter Name	Setting Range	Default	Property
Group P9: Fault and Protection				
P9.00	Motor overload protection selection	0: Disabled 1: Enabled	1	☆
P9.01	Motor overload protection gain	0.20-10.00	1.00	☆
P9.02	Motor overload warning coefficient	50%-100%	80%	☆
P9.03	Overvoltage stall gain	0-100	0	☆
P9.04	Overvoltage stall protective voltage	120%-150%	130%	☆
P9.05	Over current stall gain	0-100	20	☆
P9.06	Over current stall protective current	100%-200%	150%	☆
P9.07	Short-circuit to ground upon power-on	0: Disabled 1: Enabled	1	☆
P9.09	Fault auto reset times	0-20	0	☆
P9.10	M01 action during fault auto reset	0: Not act 1: Act	0	☆
P9.11	Time interval of fault auto reset	0.1s-100.0s	1.0s	☆
P9.12	Reserved			
P9.13	Output phase loss protection selection	0: Disabled 1: Enabled	1	☆

Function Code	Parameter Name	Setting Range	Default	Property
P9.14	1st fault type	0: No fault 1: Inverter unit protection 2: Overcurrent during acceleration 3: Overcurrent during deceleration 4: Overcurrent at constant speed 5: Overvoltage during acceleration	-	●
P9.15	2nd fault type	6: Overvoltage during deceleration 7: Overvoltage at constant speed 8: Buffer resistance overload 9: Undervoltage 10: AC drive overload 11: Motor overload 12: Reserved 13: Power output phase loss 14: Module overheat 15: External equipment fault 16: Communication fault	-	●
P9.16	3rd (latest) fault type	17: Contactor fault 18: Current detection fault 19: Motor auto-tuning fault 20: Reserved 21: EEPROM read-write fault 22: AC drive hardware fault 23: Short circuit to ground 24: Reserved 25: Reserved 26: Accumulative running time reached 27: Reserved 28: Reserved 29: Accumulative power-on time reached 30: Load becoming 0 31: PID feedback lost during running 40: With-wave current limit fault 41-43: Reserved 51: Reserved	-	●

Function Code	Parameter Name	Setting Range	Default	Property
P9.17	Frequency upon 3rd fault	-	-	●
P9.18	Current upon 3rd fault	-	-	●
P9.19	Bus voltage upon 3rd fault	-	-	●
P9.20	Input terminal status upon 3rd fault	-	-	●
P9.21	Output terminal status upon 3rd fault	-	-	●
P9.22	AC drive status upon 3rd fault	-	-	●
P9.23	Power-on time upon 3rd fault	-	-	●
P9.24	Running time upon 3rd fault	-	-	●
P9.27	Frequency upon 2nd fault	-	-	●
P9.28	Current upon 2nd fault	-	-	●
P9.29	Bus voltage upon 2nd fault	-	-	●
P9.30	Input terminal status upon 2nd fault	-	-	●
P9.31	Output terminal status upon 2nd fault	-	-	●
P9.32	Frequency upon 2nd fault	-	-	●
P9.33	Current upon 2nd fault	-	-	●
P9.34	Bus voltage upon 2nd fault	-	-	●
P9.37	Input terminal status upon 1st fault	-	-	●
P9.38	Output terminal status upon 1st fault	-	-	●

Function Code	Parameter Name	Setting Range	Default	Property
P9.39	Frequency upon 1st fault	-	-	●
P9.40	Current upon 1st fault	-	-	●
P9.41	Bus voltage upon 3rd fault	-	-	●
P9.42	Input terminal status upon 1st fault	-	-	●
P9.43	Output terminal status upon 1st fault	-	-	●
P9.44	Frequency upon 1st fault	-	-	●
P9.47	Fault protection action selection 1	Unit's digit: Motor overload (OL1) 0: Coast to stop 1: Stop according to the stop mode 2: Continue to run Ten's digit: Reserved Hundred's digit: Power output phase loss (LO) Thousand's digit: External equipment fault (EF) Ten thousand's digit: Communication fault (CE)	00000	☆
P9.48	Fault protection action selection 2	Unit's digit Reserved 0: Coast to stop Ten's digit: EEPROM read-write fault (EEP) 0: Coast to stop 1: Stop according to the stop mode Hundred's digit: Reserved Thousand's digit: Reserved Ten thousand's digit: Accumulative running time reached (END1)	00000	☆

Function Code	Parameter Name	Setting Range	Default	Property
P9.49	Fault protection action selection 3	Unit's digit: Reserved 0: Coast to stop 1: Stop according to the stop mode 2: Continue to run Ten's digit: Reserved 0: Coast to stop 1: Stop according to the stop mode 2: Continue to run Hundred's digit: Accumulative power-on time reached (END2) 0: Coast to stop 1: Stop according to the stop mode 2: Continue to run Thousand's digit: Load becoming 0 0: Coast to stop 1: Stop according to the stop mode 2: Continue to run at 7% of rated motor frequency and resume to the set frequency if the load recovers Ten thousand's digit: PID feedback loss of running 0: Coast to stop 1: Stop according to the stop mode 2: Continue to run	00000	☆
P9.50	Reserved			
P9.54	Frequency selection for continuing to run	0: Current running frequency 1: Set frequency 2: Frequency upper limit 3: Frequency lower limit 4: Backup frequency upon abnormality	0	☆
P9.55	Backup frequency upon abnormality	60.0%-100.0%	100.0%	☆
P9.56	Reserved			
P9.57	Reserved			
P9.58	Reserved			

Function Code	Parameter Name	Setting Range	Default	Property
P9.59	Action selection at instantaneous power failure	0: Invalid 1: Decelerate 2: Decelerate to stop	0	☆
P9.60	Action pause judging voltage at instantaneous power failure	0.0%-100.0%	100.0%	☆
P9.61	Voltage rally judging time at instantaneous power failure	0.00s-100.00s	0.50s	☆
P9.62	Action judging voltage at instantaneous power failure	60.0%-100.0% (standard bus voltage)	80.0%	☆
P9.63	Protection upon load becoming 0	0: Disabled 1: Enabled	0	☆
P9.64	Detection level of load becoming 0	0.0-100.0%	10.0%	☆
P9.65	Detection time of load becoming 0	0.0-60.0s	1.0s	☆
P9.67	Reserved			
P9.68	Reserved			
P9.69	Reserved			
P9.70	Reserved			
Group PA: Process Control PID Function				
PA.00	PID setting source	0: PA.01 1: FIV 2: FIC/AVI 3: Reserved 4: PULSE setting(S3) 5: Communication setting 6: Multi-reference	0	☆
PA.01	PID digital setting	0.0%-100.0%	50.0%	☆

Function Code	Parameter Name	Setting Range	Default	Property
PA.02	PID feedback source	0: FIV 1: FIC/AVI 2: Reserved 3: FIV-FIC 4: PULSE setting(S3) 5: Communication setting 6: FIV+FIC 7: MAX (FIV , FIC) 8: MIN (FIV , FIC)	0	☆
PA.03	PID action direction	0: Forward action 1: Reverse action	0	☆
PA.04	PID setting feedback range	0-65535	1000	☆
PA.05	Proportional gain Kp1	0.0-100.0	20.0	☆
PA.06	Integral time T11	0.01s-10.00s	2.00s	☆
PA.07	Differential time Td1	0.000s-10.000s	0.000s	☆
PA.08	Cut-off frequency of PID reverse rotation	0.00-maximum frequency	2.00Hz	☆
PA.09	PID deviation limit	0.0%-100.0%	0.0%	☆
PA.10	PID differential limit	0.00%-100.00%	0.10%	☆
PA.11	PID setting change time	0.00-650.00s	0.00s	☆
PA.12	PID feedback filter time	0.00-60.00s	0.00s	☆
PA.13	PID output filter time	0.00-60.00s	0.00s	☆
PA.14	Reserved			
PA.15	Proportional gain Kp2	0.0-100.0	20.0	☆
PA.16	Integral time T2	0.01s-10.00s	2.00s	☆
PA.17	Differential time Td2	0.000s-10.000s	0.000s	☆
PA.18	PJD parameter switchover condition	0: No switchover 1: Switchover via S 2: Automatic switchover based on deviation	0	☆

Function Code	Parameter Name	Setting Range	Default	Property
PA.19	PID parameter switchover deviation 1	0.0%-PA.20	20.0%	☆
PA.20	PID parameter switchover deviation 2	PA.19-100.0%	80.0%	☆
PA.21	PID initial value	0.0%-100.0%	0.0%	☆
PA.22	PID initial value holding time	0.00-650.00s	0.00s	☆
PA.23	Maximum deviation between two PID outputs in forward	0.00%-100.00%	1.00%	☆
PA.24	Maximum deviation between two PID outputs in reverse	0.00%-100.00%	1.00%	☆
PA.25	PID integral property	Unit's digit: Integral separated 0: Invalid 1: Valid Ten's digit: Whether to stop integral operation when the output reaches 0: Continue integral operation 1: Stop integral operation	00	☆
PA.26	Detection value of PID feedback loss	0.0%: Not judging feedback loss 0.1%-100.0%	0.0%	☆
PA.27	Detection time of PID feedback loss	0.0s-20.0s	0.0s	☆
PA.28	PID operation at stop	0: No PID operation at stop 1: PID operation at stop	0	☆
Group Pb: Swing Frequency, Fixed Length and Count				
Pb.00	Swing frequency setting mode	0: Relative to the central frequency 1: Relative to the maximum frequency	0	☆
Pb.01	Swing frequency amplitude	0.0%-100.0%	0.0%	☆
Pb.02	Jump frequency amplitude	0.0%-50.0%	0.0%	☆

Function Code	Parameter Name	Setting Range	Default	Property
Pb.03	Swing frequency cycle	0.1s-3000.0s	10.0s	☆
Pb.04	Triangular wave rising time coefficient	0.1%-100.0%	50.0%	☆
Pb.05	Set length	0m-65535m	1000m	☆
Pb.06	Actual length	0m-65535m	0m	☆
Pb.07	Number of pulses per meter	0.1-6553.5	100.0	☆
Pb.08	Set count value	1-65535	1000	☆
Pb.09	Designated count value	1-65535	1000	☆
Group PC: Multi-Reference and Simple PLC Function				
PC.00	Reference 0	-100.0%-100.0%	0.0%	☆
PC.01	Reference 1	-100.0%-100.0%	0.0%	☆
PC.02	Reference 2	-100.0%-100.0%	0.0%	☆
PC.03	Reference 3	-100.0%-100.0%	0.0%	☆
PC.04	Reference 4	-100.0%-100.0%	0.0%	☆
PC.05	Reference 5	-100.0%-100.0%	0.0%	☆
PC.06	Reference 6	-100.0%-100.0%	0.0%	☆
PC.07	Reference 7	-100.0%-100.0%	0.0%	☆
PC.08	Reference 8	-100.0%-100.0%	0.0%	☆
PC.09	Reference 9	-100.0%-100.0%	0.0%	☆
PC.10	Reference10	-100.0%-100.0%	0.0%	☆
PC.11	Reference11	-100.0%-100.0%	0.0%	☆
PC.12	Reference12	-100.0%-100.0%	0.0%	☆
PC.13	Reference13	-100.0%-100.0%	0.0%	☆
PC.14	Reference14	-100.0%-100.0%	0.0%	☆
PC.15	Reference15	-100.0%-100.0%	0.0%	☆
PC.16	Simple PLC running mode	0: Stop after the AC drive runs one cycle 1: Keep final values after the AC drive runs one cycle 2: Repeat after the AC drive runs one cycle	0	☆

Function Code	Parameter Name	Setting Range	Default	Property
PC.17	Simple PLC retentive selection	Unit's digit: Retentive upon power failure 0: No 1: Yes Ten's digit: Retentive upon stop 0: No 1: Yes	00	☆
PC.18	Running time of simple PLC reference 0	0.0s(h)-6553.5s(h)	0.0s(h)	
PC.19	Acceleration/deceleration time of simple PLC reference 0	0-3	0	
PC.20	Running time of simple PLC reference 1	0.0s(h)-6553.5s(h)	0.0s(h)	☆
PC.21	Acceleration/deceleration time of simple PLC reference 1	0-3	0	☆
PC.22	Running time of simple PLC reference 2	0.0s(h)-6553.5s(h)	0.0s(h)	☆
PC.23	Acceleration/deceleration time of simple PLC reference 2	0-3	0	☆
PC.24	Running time of simple PLC reference 3	0.0s(h)-6553.5s(h)	0.0s(h)	☆
PC.25	Acceleration/deceleration time of simple PLC reference 3	0-3	0	☆
PC.26	Running time of simple PLC reference 4	0.0s(h)-6553.5s(h)	0.0s(h)	☆
PC.27	Acceleration/deceleration time of simple PLC reference 4	0-3	0	☆

Function Code	Parameter Name	Setting Range	Default	Property
PC.28	Running time of simple PLC reference 5	0.0s(h)-6553.5s(h)	0.0s(h)	☆
PC.29	Acceleration/deceleration time of simple PLC reference 5	0-3	0	☆
PC.30	Running time of simple PLC reference 6	0.0s(h)-6553.5s(h)	0.0s(h)	☆
PC.31	Acceleration/deceleration time of simple PLC reference 6	0-3	0	☆
PC.32	Running time of simple PLC reference 7	0.0s(h)-6553.5s(h)	0.0s(h)	☆
PC.33	Acceleration/deceleration time of simple PLC reference 7	0-3	0	☆
PC.34	Running time of simple PLC reference 8	0.0s(h)-6553.5s(h)	0.0s(h)	☆
PC.35	Acceleration/deceleration time of simple PLC reference 8	0-3	0	☆
PC.36	Running time of simple PLC reference 9	0.0s(h)-6553.5s(h)	0.0s(h)	☆
PC.37	Acceleration/deceleration time of simple PLC reference 9	0-3	0	☆
PC.38	Running time of simple PLC reference 10	0.0s(h)-6553.5s(h)	0.0s(h)	☆
PC.39	Acceleration/deceleration time of simple PLC reference 10	0-3	0	☆

Function Code	Parameter Name	Setting Range	Default	Property
PC.40	Running time of simple PLC reference 11	0.0s(h)-6500.0s(h)	0.0s(h)	☆
PC.41	Acceleration/deceleration time of simple PLC reference 11	0-3	0	☆
PC.42	Running time of simple PLC reference 12	0.0s(h)-6500.0s(h)	0.0s(h)	☆
PC.43	Acceleration/deceleration time of simple PLC reference 12	0-3	0	☆
PC.44	Running time of simple PLC reference 13	0.0s (h)-6500.0s(h)	0.0s(h)	☆
PC.45	Acceleration/deceleration time of simple PLC reference 13	0-3	0	☆
PC.46	Running time of simple PLC reference 14	0.0s (h)-6500.0s(h)	0.0s(h)	☆
PC.47	Acceleration/deceleration time of simple PLC Reference 14	0-3	0	☆
PC.48	Running time of simple PLC reference 15	0.0s(h)-6500.0s(h)	0.0s(h)	☆
PC.49	Acceleration/deceleration time of simple PLC reference 15	0-3	0	☆
PC.50	Time unit of simple PLC running	0: s(second) 1: h(hour)	0	☆

Function Code	Parameter Name	Setting Range	Default	Property
PC.51	Reference 0 source	0: Set by PC.00 1: FIV 2: FIC/AVI 3: reserved 4: PULSE setting 5: PID Set by preset frequency (P010), modified via termina UP/DOWN	0	☆
Group PD: Communication Parameters				
PD.00	Baud rate	Unit's digit: MODBUS 0:300BPS 1:600BPS 2:1200BPS 3:2400BPS 4:4800BPS 5:9600BPS 6:19200BPS 7:38400BPS 8:57600BPS 9:115200BPS Ten's digit: Reserved Hundred's digit: Reserved Thousand's digit: Reserved	0005	☆
PD.01	Data format	0: No check, data format <8, N,2> 1: Even parity check, data format<8, E,1> 2: Odd Parity check, data format<8,0,1> 3: No check, data format <8, N,1> Valid for Modbus	3	☆
PD.02	Local address	1-247, 0: Broadcast address	1	☆
PD.03	Response delay	0ms-20ms	2	☆
PD.04	Communication timeout	0.0(invalid),0.1s-60.0s	0.0	☆
PD.05	Modbus protocol selection	Unit's digit: Modbus protocol 0: Non-standard Modbus protocol 1: Standard Modbus protocol Ten's digit: Reserved	1	☆
PD.06	Communication reading current resolution	0:0.01A 1:0.1A	0	☆
Group PE: Reserved				

Function Code	Parameter Name	Setting Range	Default	Property
Group PP: User-Defined Function Codes				
PP.00	User password	0-65535	0	☆
PP.01	Restore default settings	000: No operation 001: Restore factory settings except motor Parameters	0	★
Group CO: Torque Control and Restricting Parameters				
C0.00	Speed/Torque	0: Speed control	0	★
C0.01	Torque setting source in torque control	0: Digital setting (C0.03) 1: FIV 2: FIC/AVI 3: Reserved 4: PULSE setting 5: Communication setting 6: MIN (FIV, FIC) 7: MAX (FIV, FIC)	0	★
C0.03	Torque digital setting in	200.0%-200.0%	150.0%	☆
C0.05	Forward maximum frequency in torque control	0.00Hz-maximum frequency	50.00Hz	☆
C0.06	Reverse maximum frequency in torque control	0.00Hz-maximum frequency	50.00Hz	☆
C0.07	Acceleration time in torque control	0.00s-650.00s	0.00s	★
C0.08	Deceleration time in torque control	0.00s-650.00s	0.00s	☆
Group C1-C4: reserved				
Group C5: Control Optimization Parameters				
C5.00	PWM switchover frequency upper limit	0.00Hz-15.00Hz	12.00Hz	☆
C5.01	PWM modulation mode	0: Asynchronous modulation 1: Synchronous modulation	0	☆

Function Code	Parameter Name	Setting Range	Default	Property
C5.02	Dead zone compensation mode selection	0: No compensation 1: Compensation mode 1 2: Compensation mode 2	1	☆
C5.03	Random PWM depth	0: Random PWM invalid 1-10: PWM carrier frequency random depth	0	☆
C5.04	Rapid current limit	0: Disabled 1: Enabled	1	☆
C5.05	Current detection compensation	0-100	5	☆
C5.06	Undervoltage threshold	60.0%-140.0%	100.0%	☆
C5.07	SFVC optimization mode selection	0: No optimization 1: Optimization mode 1 2: Optimization mode 2	1	☆
Group C6: FI Curve Setting (FI is FIV or FIC)				
C6.00	FI curve 4 minimum input	-10.00V-C6.02	0.00V	☆
C6.01	Corresponding setting of FI curve 4 minimum input	-100.0%-+100.0%	0.0%	☆
C6.02	FI curve 4 inflection 1 input	C6.00-C6.04	3.00V	☆
C6.03	Corresponding setting of FI curve 4 inflection 1 input	-100.0%-+100.0%	30.0%	☆
C6.04	FI curve 4 inflection 2 input	C6.02-C6.06	6.00V	☆
C6.05	Corresponding setting of FI curve 4 inflection 2 input	-100.0%-+100.0%	60.0%	☆
C6.06	FI curve 4 maximum input	C6.06-+10.00V	10.00V	☆
C6.07	Corresponding setting of FI curve 4 maximum input	-100.0%-+100.0%	100.0%	☆
C6.08	FI curve 5 minimum input	-10.00V-C6.10	0.00V	☆

Function Code	Parameter Name	Setting Range	Default	Property
C6.09	Corresponding setting of FI curve 5 minimum input	-100.0%-+100.0%	-100.0%	☆
C6.10	FI curve 5 inflection 1 input	C6.08-C6.12	3.00V	☆

C6.11	Corresponding setting of FI curve 5 inflection 1 input	-100.0%~+100.0%	-30.0%	☆
C6.12	FI curve 5 inflection 2 input	C6.10-C6.14	6.00V	☆
C6.13	Corresponding setting of FI curve 5 inflection 2 input	-100.0%~+100.0%	30.0%	☆
C6.14	FI curve 5 maximum input	C6.12~+10.00V	10.00V	☆
C6.15	Corresponding setting of FI curve	-100.0%~+100.0%	100.0%	☆
C6.16	Jump point of FIV	-100.0%-100.0%	0.0%	☆
C6.17	Jump amplitude of FIV input	0.0%-100.0%	0.5%	☆
C6.18	Jump point of FIC input	-100.0%-100.0%	0.0%	☆
C6.19	Jump amplitude of FIC input	0.0%-100.0%	0.5%	☆
C9.00	PID Sleep frequency	0-P0.12	00.00 Hz	☆
C9.01	PID Sleep Time	0-5000.0S	10.0 S	☆
C9.02	PID wake-up value	0-100.0%	60.0 %	☆
Group CC: FI/FO Correction				
CC.00	FIV measured voltage 1	0.500V-4.000V	Factory-corrected	☆
CC.01	FIV displayed voltage 1	0.500V-4.000V	Factory-corrected	☆
CC.02	FIV measured voltage 2	6.000V-9.999V	Factory-corrected	☆
CC.03	FIV displayed voltage 2	6.000V-9.999V	Factory-corrected	☆

Function Code	Parameter Name	Setting Range	Default	Property
CC.04	FIC measured voltage 1	0.500V-4.000V	Factory- corrected	☆
CC.05	FIC displayed voltage 1	0.500V-4.000V	Factory- corrected	☆
CC.06	FIC measured voltage 2	6.000V-9.999V	Factory- corrected	☆
CC.07	FIC displayed voltage 2	6.000V-9.999V	Factory- corrected	☆
CC.08	Reserved		Factory- corrected	☆
CC.09	Reserved		Factory- corrected	☆
CC.10	Reserved		Factory- corrected	☆
CC.11	Reserved		Factory- corrected	☆
CC.12	FOV target voltage 1	0.500V-4.000V	Factory- corrected	☆
CC.13	FOV measured voltage 1	0.500V-4.000V	Factory- corrected	☆
CC.14	FOV target voltage 2	6.000V-9.999V	Factory- corrected	☆
CC.15	FOV measured voltage 2	6.000V-9.999V	Factory- corrected	☆
CC.16	Reserved		Factory- corrected	☆
CC.17	Reserved		Factory- corrected	☆
CC.18	Reserved		Factory- corrected	☆
CC.19	Reserved		Factory- corrected	☆

Group D0: Monitoring Parameters

Function Code	Parameter Name	Unit
D0.00	Running frequency (Hz)	0.01Hz
D0.01	Set frequency (Hz)	0.01Hz
D0.02	Bus voltage (V)	0.1V
D0.03	Bus voltage (V)	1V

Function Code	Parameter Name	Unit
D0.04	Output current(A)	0.01A
D0.05	Output power(kW)	0.1kW
D0.06	Output torque (%)	0.1%
D0.07	S input state	1
D0.08	M01 output state	1
D0.09	FIV voltage(V)	0.01V
D0.10	FIC voltage(V)	0.01V
D0.11	Reserved	
D0.12	Count value	1
D0.13	Length	1
D0.14	Load speed	1
D0.15	PID setting	1
D0.16	PID feedback	1
D0.17	PLC stage	1
D0.18	Input pulse frequency	0.01kHz
D0.19	Reserved	
D0.20	Remaining running time	0.1Min
D0.21	FIV voltage before correction	0.001V
D0.22	FIC voltage before correction	0.001V
D0.23	Reserved	
D0.24	Linear speed	1m/Min
D0.25	On the current time	1Min
D0.26	The current running time	0.1Min
D0.27	Pulse input frequency	1Hz
D0.28	Communication setting value	0.01%
D0.29	Reserved	
D0.30	Reserved	
D0.31	Auxiliary frequency Y	0.01Hz
D0.32	View any memory address values	1
D0.33	Reserved	

Function Code	Parameter Name	Unit
D0.34	Motor temperature	1°C
D0.35	Target torque	0.1%
D0.36	Reserved	
D0.37	Power factor angle	0.1
D0.38	Reserved	
D0.39	Target voltage upon V/F separation	1V
D0.40	Output voltage upon V/F separation	1V
D0.41	Reserved	
D0.42	Reserved	
D0.43	Reserved	
D0.44	Reserved	
D0.45	Current fault code	0

Error Code	Name	Error Code	Name
OC1	Over current during acceleration	RAY	Connector error
OC2	Over current during deceleration	IE	Current detection error
OC3	Over current during constant speed	TE	Motor self-learning error
OU1	Over voltage during acceleration	EEP	EEPROM Read/Write error
OU2	Over voltage during deceleration	GND	Short circuit to ground
OU3	Over voltage during constant speed	END1	Cumulative running time reached
POF	Control power	END2	Cumulative power-on time reached
LU	Under voltage	LOAD	Load drop error
OL2	AC drive overload	PIDE	PID feedback loss during the operation
OL1	Motor overload	CBC	Fast current limiting
LI	Input phase loss	ESP	Excessive Speed deviation
LO	Output phase loss	OSP	Motor over speed
OH	Module overheat	CE	Communication error
EF	External device fault		

Chapter 5 Communication Protocol

VNZ200 series inverter provides RS485 communication interface, and support the Modbus communication protocol. Users can achieve central control by computer PLC, through the communication protocol to set inverter running instructions, modify or read function code parameters, and read the inverter working condition and fault information, etc.

5.1 The agreement content

The serial communication protocol defines the serial communication transmission of information content and format. Including: host polling or broadcasting format; Host encoding method, the content includes: the function of the required action code, data transmission and error checking, etc. From the response of machine should be used in the same structure, content including: action confirmation, data return and error checking, etc. If there was an error in receiving information from a machine, or cannot achieve the requirements of the master, it will organize a fault feedback information in response to the master.

5.2 Application methods

Application mode inverter with RS485 bus access to the "Single master and multi slaves" PC/PLC control network.

5.3 Bus structure

(1) The interface is RS485 interface.

(2) Asynchronous serial transmission mode, half-duplex transmission mode. At the same time, for the master and the slaves, the one can only send data from the machine and the other can only receive data.

In the process of serial asynchronous communication, data is sent a frame by a frame in the form of message,.

(3) Topological structure from single master machine system. Slave machine address is set in the range the of 1-247, 0 for broadcast communication address. In the network, the slave machine address must be unique.

5.4 Protocol Description

VNZ200 series inverter is a kind of asynchronous serial port communication protocol of master-slave Modbus communication protocol, the network has only one equipment (master) to establish agreement (called "query/command"). Other equipment (salves) can only provide data response of the main machine "query command", or "query/command" to make the corresponding actions to the master. Master refers to the personal computer (PC), industrial control equipment or programmable logic controller (PLC), etc. Slave machine refers to VNZ200 inverter. The master can communicate to a separate slave machine, also can to all under a broadcast information slave machine released. For access to the master alone "query/command", from the machine to return to an information (called response), for broadcast information from the master, slave machine can have no feedback to the host.

5.5 Communications data structure

Modbus protocol communication data format of VNZ200 series inverter is as follows: using the RTU mode, messages are sent at least begin with 3.5 characters pause time interval.

Network baud rate under varied characters of the time, this is the easiest to implement (below T1, T2, T3, T4).

Equipment address is the first domain.

The transmission character can used is the hex 0...9, A....F. Continuously detect network bus network facilities, including pause interval of time. When the first domain (address domain) to receive, every equipment decodes to determine whether to own. After the last transmission character, a pause of at least 3.5 characters time calibration for the end of the message. A new message can be started after the pause.

The entire message frame must be as a continuous flow of transmission. If there is a pause time with more than 1.5 characters before the frame complete, receiving equipment will refresh incomplete message.

And assume that the next byte is the address domain of a new message. Likewise, if a new message starts in less than 3.5 characters of time and then a message before, receiving equipment will think it is a continuation of the previous message. This will result in an error, because in the final CRC field value can't be right.

RTU frame format:

The frame header START	3.5 characters
Slave address ADR	Communication address:1~247
command code CMD	03: Read the machine parameters; 06: write the machine parameters
Date content DATA (N-1)	Information content: Function code parameter address, function code number of parameters, function code parameter values, etc
Data content DATA (N-2)	
.....	
Data content DATA0	
High-order position of CRC CHK	Estimated value: CRC value
Low-order position of CRC CHK	
END	3.5 characters time

CMD (Command instruction) and DATA (the description of data word)

command code: 03H, read N words (Word) (at most 12 words). For example, slave machine address as 01 of inverter startup F105 continuous read for two consecutive values.

The host command information

ADR	01H
CMD	03H
High-order position of the starting address	F1H
Low-order position of the starting address	05H
High-order position of register	00H
Low-order position of register	02H
Low-order position of CRC CHK	Wait for calculating the CRC CHK values
high-order position of CRC CHK	

Slave machine response information

Set PD.05 to 0:

ADR	01H
CMD	03H
High-order position of bytes	00H
Low-order position of bytes	04H

Data high-order position of F002H	00H
Data low-order position of F002H	00H
Data high-order position of F003H	00H
Data low-order position of F003H	01H
Low-order position of CRC CHK	Wait for calculating the CRC CHK values
High-order position of CRC CHK	

Set PD.05 to 1:

ADR	01H
CMD	03H
The number of bytes	04H
Data high-order position of F002H	00H
Data low-order position of F002H	00H
Data high-order position of F003H	00H
Data low-order position of F003H	01H
Low-order position of CRC CHK	Wait for calculating the CRC CHK values
High-order position of CRC CHK	

The command code:06H write a word (Word)For example, write 000(BB8H) to slave machine.

Address 05H inverter's F00AH address.

The host command information

ADR	05H
CMD	06H
High-order position of data address	FOH
Low-order position of data address	OAH
high-order position of information content	0BH
Low-order position of information content	B8H
Low-order position of CRC CHK	Wait for calculating the CRC CHK values
High-order position of CRC CHK	

In response to information from the slave machine

ADR	02H
CMD	06H
High-order position of data address	FOH
Low-order position of data address	OAH
High-order position of information content	13H
Low-order position of information content	88H
Low-order position of CRC CHK	Wait for calculating the CRC CHK values
High-order position of CRC CHK	

Check method—CRC Check method: CRC (Cyclical Redundancy Check) use RTU frame format, the message includes error detection field based on the method of CRC. CRC domain test the whole content of a message. CRC domain is two bytes, contains a 16-bit binary values. It is calculated by the transmission equipment and added to the message. Received device recalculate CRC which receives message. And compared with the value in the CRC domain, if the two CRC value is not equal, then there is an error in transmission.

CRC is saved in 0xFFFF. Then call a process to continuous 8-bit bytes of the message and the values in the current register for processing. Only 8-bit data in each character of CRC is effective, starting bit and stopping bit and parity bits are invalid.

In the process of CRC, each of the 8-bit characters are separate and dissimilar or register contents (XOR), The results move to the least significant bit direction, set the most significant bit to 0. LSB is extracted to test, if set LSB to 1, Register and preset value dissimilarity or alone, if set LSB to 0, is not to. The whole process will repeat 8 times. when the last time (the eighth time) is completed, next 8-bit bytes and separate and register under the current value of the alien or. The values in the final register, is all bytes in the message is executed after the CRC value.

When CRC added to the messages. The low byte to join first and then high byte. CRC Simple function is as follows:

```
unsigned int crc_cal_value (unsigned char *data_value, unsigned char data_length)
```

```
int i;
```

```
unsigned int crc_value=0xffff;
```

```
while(data_length--)
```

```
    crc_value^=*data_value++;
```

```
    for(i=0;i<8;i++)
```

```
        If(crc_value&0x0001)
```

```
            crc_value=(crc_value>>1)^0xa001;
```

```
        else
```

```
            crc_value=crc_value>>1;
```

```
    }
```

```
    Return(crc_value);
```

Address definition of communication parameters

This part is the content of the communication, used to control the operation of the inverter, inverter status and related parameters setting. Read and write functional code parameter (Some function code which cannot be changed, only for the use of manufacturers or monitoring): function code parameter address label rules:

By function block number and the label for the parameter address representation rules. High byte: F0~FF (P group), A0~AF(C group), 70~7F(D group) Low byte: 00~FF

Such as: P3.12, The address is expressed as F30C; Attention: PF group: Neither read the parameters, and do not change parameters; Group D group: only can read, do not change the parameters.

When some parameters is in inverter operation, can not change; Some parameters of the inverter in any status, cannot be changed; Change function code parameters, but also pay attention to the range of parameters, units, and related instructions.

In addition, because the EEPROM is stored frequently, the service life of the block EEPROM can reduced. Some function codes in the mode of communication do not need to be stored, just changing the value of RAM. If it is parameters of P group, in order to realize the function, as long as putting this function code address high F into 0. If

it is parameters of C group, in order to realize the function, as long as putting the function code the address of high A into 4.

Corresponding function codes are shown as the following address:

the high byte: 00 0F (P group),40 4F (C group) low byte: 00 to FF

Such as:

Function code P3.12 is not stored in the EEPROM, the address is expressed as 030C; Function code C0.05 is not stored in the EEPROM, the address is expressed as 4005. The address representation can only do writing RAM, can't read. When reading, it is an invalid address. For all the parameters, using the command code 7H to realize this function.

Stopping/starting parameters:

Parameter address	Parameter description
1000	Communication Setting value (-10000-10000) (Decimal system)
1001	Operating frequency
1002	Bus voltage
1003	Output voltage
1004	Current output
1005	Output power
1006	Output torque
1007	Running velocity
1008	S Input Flag
1009	MO1 output Flag
100A	FIV voltage
100B	FIC voltage
100C	Reserved
100D	Count value input
100E	The length value input
100F	Load speed
1010	PID setting
1011	PID feedback
1012	PLC steps
1013	PULSE the input pulse frequency, unit 0.01kHz
1014	Reserved
1015	The remaining running time
1016	FIV before correction voltage
1017	FIC before correction voltage
1018	Reserved
1019	Linear velocity
101A	The current access to electricity time
101B	The current running time
101C	PULSE input pulse frequency, unit 1Hz

101D	Communication Setting value
101E	Reserved
101F	The main frequency X show
1020	Auxiliary frequency Y show

Attention:

Communication setting value is relative percentage, 10000 corresponds to 100.00% and -10000 corresponding to -100.00%. The frequency of dimensional data, the percentage is relative to the percentage of maximum frequency (P0.12); Counter rotating torque dimensional data, the percentage is P2.10.

Control command input to the inverter: (Write-only)

The command word address	Command function
2000	0001: Running forward
	0002: Reverse running
	0003: Normal inching turning
	0004: Reverse JOG
	0005: Free downtime
	0006: Slowing down
	0007: Failure reset

Read the inverter status: (Read-only)

Status word address	Status word function
3000	0001: Running forward
	0002: Reverse running
	0003: Shutdown

Parameters lock password check: (if return for 8888H. It indicates that the password checks through)

Password address	The content of the input password
1F00	*****
Command address	Command content
2001	BIT0: (Reserved) BIT1: (Reserved) BIT2: RA-RB-RC output control BIT3: Reserved BIT4: M01 output control

Analog output FOV control: (Write-only)

Command address	Command content
-----------------	-----------------

2002	0-7FFF represent 0%-100%
------	--------------------------

Analog output control:	(Reserved)
Command address	Command content
2003	0-7FFF represent 0%-100%

PULSE (PULSE) output control: (Write-only)

Command address	Command content
2004	0-7FFF represent 0%-100%

Inverter fault description:

Inverter fault address	Inverter fault information
8000	0000: No fault 0001: Inverter unit fault 0002: Accelerate over current 0003: Decelerate over current 0004: Constant speed over current 0005: Accelerate over the voltage 0006: Decelerate over voltage 0007: Constant speed over voltage 0008: Control power fault 0009: Under-voltage fault 000A: The inverter overloads 000B: Motor overload 000C: Reserved 000D: The output phases 000E: Module is overheating 000F: External fault 0010: Abnormal communication

8000	0011: Abnormal contactor 0012: Current detection fault 0013: Motor tuning fault 0014: Reserved 0015: Abnormal parameter read and write 0016: Inverter hardware failure 0017: Motor short circuit fault 0018: Reserved 0019: Reserved 001A: Running time reached 001B: Reserved 001C: Reserved
------	--

	001D: Accumulative power-on time reached 001E: Load becoming 0 001 F: PID feedback lost during running 0028: Rapid current limit fault
Communication fault address	Fault feature description
8001	0000: No fault 0001: Password mistake 0002: The command code error 0003: CRC Checking error 0004: Invalid address 0005: Invalid parameter 0006: Correcting parameter is invalid 0007: System is locked 0008: EEPROM operation

PD group communication parameters

PD.00	Baud rate	The factory value	0005
	Setting range	Units1 digit: MODUBS Baud rate 0: 300BPS 1: 600BPS 2: 1200BPS 3: 2400BPS 4: 4800BPS 5: 9600BPS 6: 19200BPS 7: 38400BPS 8: 57600BPS 9: 115200BPS	

This parameter is used to set data transfer rate between the PC and inverter. Note that setting the baud rate of upper machine and inverter must agree. Otherwise, the communication can't carry on the faster the baud rate, the greater the communication.

PD.01	Data format	Default	0
	Setting range	0: No check: The data format <8,N,2> 1: Even-parity: The data format <8,E,1> 2: Odd parity check: The data format <8,0,1> 3: No check: The data format <8,N,1>	

PC and data format set by the inverter must agree, otherwise, the communication can't carry on.

PD.02	Machine address	Default	1
	Setting range	1-247, 0 is the broadcast address	

When the machine address set to 0, namely for the broadcast address, realize PC broadcasting functions.

The machine address has uniqueness (except the broadcast address), which is to achieve the basis of upper machine and inverter peer-to-peer communications.

PD.03	Response delay	Default	0
-------	----------------	---------	---

	Setting range	0-20ms
--	---------------	--------

Response latency: refers to the inverter data to accept the end up to an upper machine to send data in the middle of the interval of time. If the response time delay is less than the system processing time, the response time delay will be subject to system processing time, processing time, such as response time delay is longer than system after processing the data, the system will delay waiting, until the response delay time to up to an upper machine to send data.

PD.04	Communication timeout	Default	0.0s
	Setting range	0.0s (Invalid) 0.1-60.0s	

When the function code is set to 0.0s, communication timeout parameter is invalid. When the function code set to valid values, if a communication and the interval time of the next communication beyond the communication timeout, system will be submitted to the communication failure error (CE). Usually, it is set into is invalid. If in the continuous communication system parameter set the time, you can monitor the communication status.

PD.05	Communication protocol selection	Default	1
	Setting range	0: Nonstandard Modbus protocol 1: The standard Modbus protocol	

PD.05=1: Choose the standard Modbus protocol

PD.05=0: When reading command. Returns number of bytes from the machine is a byte more than the standard Modbus protocol, detailed in this agreement 5 communication data structures.

PD.06	Read the current resolution	Default	1
	Setting range	0: 0.01A 1: 0.1A	

Used to determine the communication while reading the output current, current value of the output units.

We reserve the right of this manual contained information change without notice in advance.

Wecon Technology Co., Ltd

Factory Address: 10th Building, Area E, Fuzhou Software Park, Gulou District, Fuzhou, Fujian Province, P.R.China

R&D Center: Floor 5-6, Block 6, Area F, Fuzhou Software Park, Gulou District, Fuzhou ,Fujian, Province, P.R. China

Tel: +86-591-87868869 Fax: +86-591-87843899

Website: www.we-con.com.cn/en

Email: sales@we-con.com.cn