



LX3V-1WT-L

User manual



Wecon Technology Co.,Ltd.

Website: <http://www.we-con.com.cn/en>

Technical Support: support@we-con.com.cn

Skype: fcwkkj

Tel: 86-591-87868869

QQ Group: 465230233

Technical forum: <http://wecon.freeforums.net>



1. Weighing module Operating principle

Electrical resistance of metal material changes in proportion to the forces being applied to deform it. The strain gauge measures the deformation as a change in electrical resistance, which is a measure of the strain and hence the applied forces (load).

2. Introduction

- 1) WECON LX3V-1WT-L expansion module's resolution is 18-bit. The module can be used for reading signals from 4- or 6- wire configuration;
- 2) Please read through the manual before powering on the module.
- 3) This manual is only applicable for model number: LX3V-1WT-L. Please double check the mark on your module.
- 4) Using FROM/TO command to read/write data on PLC LX3V.

2.1 Specification

Table 2-1

Item	Description
Channel	Signal channel
A/D converter	18 bit $\Delta\Sigma$ A/D
Resolution	18bit (signed)
Speed	7.5--4800Hz available
Polarity	Unipolar and bipolar
Non-linearity	$\leq 0.01\%$ full scale(25°C)
Zero drift	$\leq 0.2\mu\text{V}/^\circ\text{C}$
Gain drift	$\leq 10\text{ppm}/^\circ\text{C}$
Excitation Voltage/ load	5V, load impedance $\geq 200\Omega$
Sensor sensitivity	1mV/V-15mV/V
Isolation	Transformer (power supply) and the optical coupler (signal)
Lamp	Power supply lamp, communication lamp
Power supply	24V $\pm 20\%$ 2VA
Operating temperature	0~60 °C

Storage temperature	-20~80 °C
Dimension	90(L)x58(W)x80(H) mm

2.2 Valid bits

Refer to sampling frequency in Section 5.2, Chapter 5 of this manual.

3. Dimensions

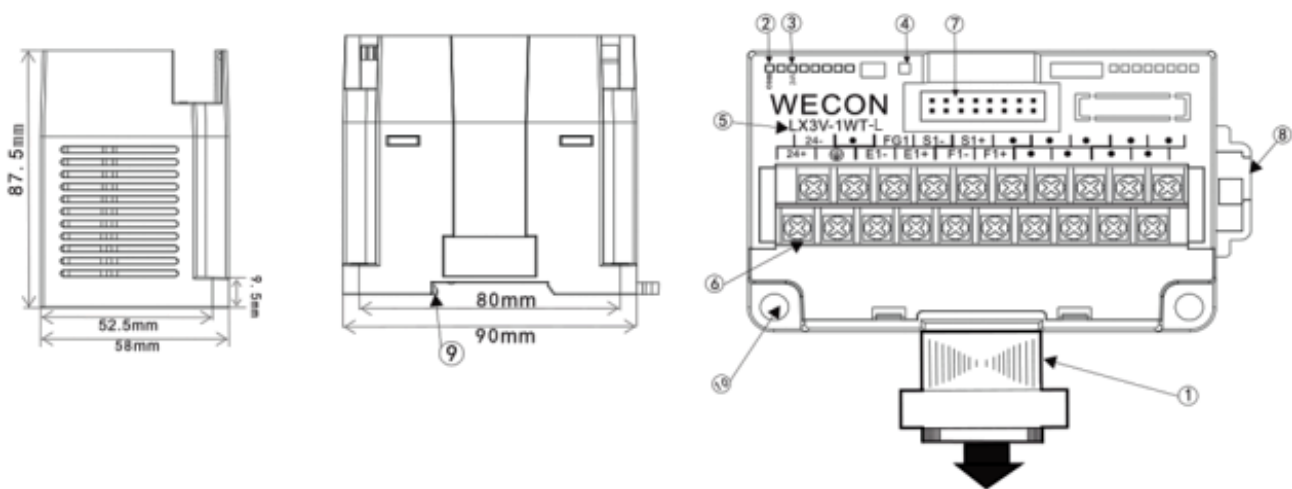

Figure 3-1

- | | |
|-------------------------------------|---------------------------------|
| ① Extension cable and connector | ⑥ Analog signal output terminal |
| ② LED COMM: lit when communicating | ⑦ Extension module interface |
| ③ Power LED: Lit when power present | ⑧ DIN rail mounting slot |
| ④ State LED: Lit when normal | ⑨ DIN rail hook |
| ⑤ Module number | ⑩ Mounting holes ($\phi 4.5$) |

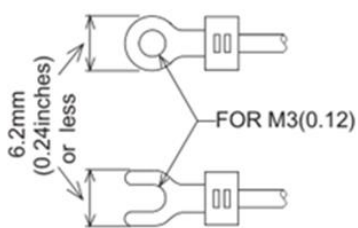

Figure 3-2

- Use the crimp terminals that meet the dimensional requirements showed in the left figure.
- Apply 0.5 to 0.8 N.m (5 to 8 kgf.cm) torque to tighten the terminals against disoperation.

3.1 Terminals instruction

Table 3-1

Terminals	Instruction
24V+	Power supply+
24V-	Power supply-
GND	Grounding
FG1	Sensor grounding
E1-	Power supply- (5V) for sensor
E1+	Power supply+ (5V) for sensor
S1-	Signal output – of sensor
S1+	Signal output + of sensor
F1-	Feedback – of sensor
F1+	Feedback + of sensor
●	

4. Wiring

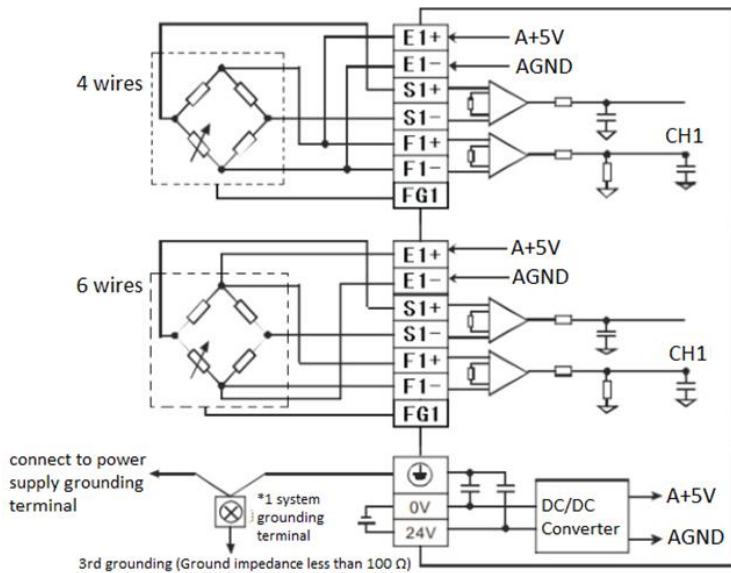

Note:

- 1) Impedance of the weighing sensor is greater than 50 Ω.
- 2) Sensors with 4 wires need to have E1+ and F1+ connected, E1- and F1- connected.

5. BFM instruction

5.1 BFM list

Table 0-1

BFM	Latched	Read/Write	Function	Default	Range	Description
0	0	R	Model	5013		LX3V-1WT-L model number
1	0	R	System version	18041		Software & hardware version
2	0	R/W	Unipolar/ Bipolar	0	0-1	0: bipolar 1: unipolar
3	0	R/W	Frequency	1	0-4800	0: 7.55 Hz; 5: 150 Hz; 1: 10 Hz; 6: 300 Hz; 2: 25 Hz; 7: 600 Hz; 3: 50 Hz; 8: 960 Hz; 4: 60 Hz; 9: 2400 Hz; 10--4800:10--4800HZ
4	X	R	State	0		See the "Buffer register BFM4 description" for details of each status code
5	X	R	Error Code	0		0: No error; 1: Error; b0: Power supply error b1: Hardware error b2: CH1 conversion error b3-b15: Reserved
6	X	R/W	Tare weight Preset	0		Use average weight as tare weight: 0: Disabled 1: Set tare weight then reset to 0;
7	0	R/W	Gross/Net weight	0		Display gross weight or net weight 0: CH1 gross weight; 1: CH1 net weight; Others: CH1 invalid;

8	X	R/W	Weight Calibration	0		Defaulted to 0 0x0001:CH1 set to 0 0x0002:CH1 calibrating:
9	X	R/W	Reset to default	0	1:reset	Reset all BFM values to default
10	O	R/W	Filtering mode	0	0-1	Recalibration required after change
11	O	R/W	Filtering strength	3	0-7	Recalibration required after change
12	O	R/W	Zero tracking interval	0	0-20000	When the zero tracking function is turned on, the most small interval time, unit: 1 Ms.
13	O	R/W	Zero tracking range	0	0-100	0: no limit Others: limit Zero tracking range
14	O	R/W	No load Zeroing at startup	0	0-4	0: Disabled; 1: $\pm 2\%$ MAX; 2: $\pm 5\%$ MAX; 3: $\pm 10\%$ MAX; 4: $\pm 20\%$ MAX;
15	X	R/W	Sensor sensitivity setting	4	0-5	0: $< 1V/V$ 1: $< 125mV/V$ 2: $< 62.5mV/V$ 3: $< 31.25V/V$ 4: $< 15.625mV/V$ 5: $< 7.812 mV/V$ Note: Please recalibrate after setting
16	X	R	CH1 average weight L	0		Average weight of CH1 (Low word)
17			CH1 average weight H			Average weight of CH1 (High word)
18	O	R/W	CH1 sliding average	5	1-50	Setting range: K1~K50; settings outside of this range will be changed to the nearest value in the

						range.
19	0	R/W	CH1 tare weight	0		Range: K-8388608~K8388607 Default value: K0
20						
21	0	R/W	CH1 stable checking time	200	0-20000	The stable inspection time is used in conjunction with the stable inspection range Unit:ms
22	0	R/W	CH1 stable checking range	10	1-10000	If the stable check range is set to 100 and the stable check time is set to 200ms, then the current weight runout range is within 100 and keeps 200ms.this is considered to be numerical stable other conditions are considered unstable, and the stable flag bit is displayed on BFM#4.
23	0	R/W	CH1 weight value calibration (basic point of weight)	1000	-8388608~8388607	#8
24	0					
25	0	R/W	CH1 maximum	32767	-8388608~8388607	User can set the max value, it will record the error code when measured value exceed set value
26	0	R/W				
27	0	R/W	CH1 zero weight detection up limit	10	-8388608~8388607	Zero weight detection function, used to tell if all loads have been removed. Reading of the bit to indicate stable reading becoming 0 means all loads have been removed.
28	0	R/W				
29	0	R/W				
30	0	R/W	CH1 zero weight detection down limit	-10	-8388608~8388607	
31	X	R/W	Additional	0	0~1	0: Default, disable

			function options			additional functions; 1: Enable filter reset function. Other: Reserved
32	X	R/W	Additional function parameters	0	0~100	Enable filter reset function: 0: Default; 0~100: The number of sampling cycles to wait for the filter to restart. The value collected during the accumulation of the average, as the initial value of filtering
33	X	R/W	Number value L	0	-	ADC Number
34	X	R/W	Number value H	0	-	
35	X	R	Internal parameters	-	-	Internal parameters, Only read
36	X	R				
37	X	R				
38	X	R				
39	O	R/W	Set sensor sensitivity	2	0-32767	If Sensor sensitivity is 10 mV/V, then set 10 (this setting is only related to the calibrated flag.)
40	O	R/W	Sensor voltage L	0		Write: 0: not shown; 1: display the current sensor feedback voltage in real time; 2: shows the zero voltage at the time of calibration; 3: shows the voltage when weight calibration Read: Display low bit of voltage value, unit u V.
41	O	R/W	Sensor voltage H	0		Display high bit of voltage value, unit u V.

Note:

- 1) O: yes;
- 2) X: no;
- 3) R: read;
- 4) W: write;

5.2 Buffer (BFM) description

1) BFM0: Module code

LX3V-1WT-L code: 5013

2) BFM1: module version

Module version (decimal)

Example

BFM1=116, means V1.1.6

3) BFM2: Polarity

For bipolar, the signal will go through zero while it is in changing process, but unipolar will not. The result of the conversion from analog value to digital value is signed, so for bipolar signal the value could be minus.

4) BFM3: Sampling frequency

The frequency of input signal reading, the lower the frequency is, the more stable the value it gets, and the higher the precision is, but the lower speed gets.

Table 0-2

Setting	Sample frequency (HZ)	Sample precision (Bits)	Setting	Sample frequency (HZ)	Sample precision (Bits)
0	7.5	17.5	6	300	16
1	10	17.5	7	600	15.5
2	25	17	8	960	15.5
3	50	16.5	9	2400	15
4	60	16.5	4800	4800	14.5
5	150	16			

5) BFM4: State code

Table 0-3

Bit No.	1 Description	0 Description
Bit 0	CH1 no-load	CH1 load
Bit 2	CH1 over-load Note: upper limit weight set by #27, #28	CH1 no over-loaded
Bit 4	CH1 stable	CH1 is not stable
Bit 6	CH1 uncalibrated / calibrated error	CH1 calibrate successfully
Bit8	00:no error	01: No-load Calibration
Bit9	10: the Initial weight is too large	11: uncalibrated
Bit12	CH1 is beyond sensor range Note: it is determined by the sensor feedback voltage	CH1 is in sensor range
Others	reserved	

6) BFM5: Error code

Table 0-4

Bit No.	Value	Error	Bit No.	Value	Error
bit 0	K1(H0001)	Power failure	bit 1	K1(H0001)	Hardware failure
bit 2	K4(H0004)	CH1 conversion error	bit 3-bit 15	Reserved	

Note: Data register used to store all error states.

7) BFM6: Tare weight setting

Set the current weight value (BFM16-17) as a tare (BFM19-20) weight. Every bit represents a different channel, which is set to 1 to mean enabled, reset to 0 after being set.

For example

The current weight is 100, after setting tare weight;

If it displays gross weight (BFM7 = 0) currently, the tare weight (BFM19-20) will become 100, the current weight is still 100;

If it displays net weight (BFM7 = 1), the tare weight (BFM19-20) will be original value + current weight value, the current weight value becomes zero;

8) BFM 8: adjust weight instruction

Adjust to match the load weight value of weighing module with the default value of 0. User adjustment steps: explain with CH1

Step 1: no weight is placed on the load unit;

Step 2: # 8 is written as 0 x 0001;

Step 3: add standard weights to the load cell

Step 4: write the current weight to # 23,

Step 5: # 8 is written as 0 x 0002.

9) BFM11: filtering strength

The higher the filter strength is, the more stable and accurate the weight value is. But the delay time will increase accordingly, and the sensitivity will decrease.

10) BFM12: zero tracking interval

BFM# 12 is used with BFM#13 together. when BFM#13 is not zero, BFM#12 indicates the time between automatic weight clearance and the next automatic zero clearing, to prevent continuous zero clearing.

Note: this function is generally used to correct the temperature drift of the sensor.

11) BFM13: Range of Zero tracking

Accumulated range of zero tracking, stop tracking when out of range

Note: when setting the zero tracking range (absolute value), the tracking must be within the zero tracking range of the current weight and at the numerical stability.

Table 0-5

Setting	Description	Note
0	Disable zero tracking	Default
1-100	Range of weight value	10 means ± 10
Others	Reserved	
Note: This feature can be disabled when high precision is not required.		

Example

Setting value is 100, when the position within ± 100 , it will be read as no-load.

12) BFM15: Set AD chip gain

It can be set according to the sensor range

BFM15	Voltage range	Sensor sensitivity
0	$\pm 5V$	$< 1V/V$
1	$\pm 625mV$	$< 125mV/V$
2	$\pm 312.5 mV$	$< 62.5mV/V$
3	$\pm 156.2 mV$	$< 31.25mV/V$
4	$\pm 78.125 mV$	$< 15.625mV/V$
5	$\pm 39.06 mV$	$< 7.812 mV/V$

13) BFM 21 / BFM 22: stable check time and range: this function is used to determine whether the current weight value is stable.

For example: the stable check range is set to 10, the stable check time is set to 200, then within 200 ms, the current weight changes within ± 10 , the weight value is considered to be stable, and the Bit4 mark position of BFM# 4 is 1.

14) BFM 39: sensor sensitivity

According to the weighing sensor specifications, such as 2 MV/V sensor set to 2. If the sensor exceeds the range, the Bit12 mark position of BFM# 4 is 1.

15) BFM 40 BFM 41: sensor feedback voltage display.

The function is used to detect the feedback voltage in weight sensor, the voltage between the terminal S and S -. The voltage value is not displayed when the default value is 0.

BFM40 Function	Remark
0: Non-display voltage	Voltage is signed double word BFM# 40 is low word, BFM# 41 is high word.
1: Displays the current sensor feedback voltage(uV)	
2: Displays zero voltage(uV) when calibrated	
3: Display the voltage (uV) of the weight when calibrating	

5.3 Function Instructions

1) Net weight measurement

It can be set to measure net weight or gross weight. The Net weight means the weight of the product itself, that is, the actual weight of the product without its external packaging.

The weight of the packaging is called the tare weight. The gross weight is the total weight, namely the net weight plus the tare weight.

- Tare weight: weight of the packaging
- Net weight: the weight of the product, excluding the packaging.
- Gross weight: the net weight plus the tare of the product.
- Gross weight= net weight + tare weight.

For example: A product weighs 10kg and the carton contains it weighs 0.2kg, then its gross weight is 10.2 kg (net weight=10kg, tare weight=0.2kg, gross weight=10.2kg)

Example: Use the measured value at CH1 as the net weight. If you know the weight of the packaging already, you can skip the step of reading tare weight.

- Read the tare weight

Step 1: Write H0000 into BFM7.

Step 2: Place the packaging on the CH1 load cell.

Step 3: Write H0001 into BFM6 to take the weight of the packaging as the tare weight.

- Set BFM7 = H00F1.

2) Standstill check function

When an object is placed on the load cell to measure its weight, you can use the standstill check function to know whether the current reading has been stabilized.

- If the measured value shifts within the range (BFM 22) of standstill check set up by the user, BFM4'bit 4 will be set to "1".
- If the measured value shifts beyond the range for standstill check set up by the user, bit4 will be set to "0". They will be set to "1" again when the range is returned to the set range.

Example

The measuring time is 10ms, the times of standstill check is 10, and the range for standstill check is 1,000. When the range for standstill check exceeds 1,000, the reading is considered unstable, i.e. BFM4'bit4 will be set to 0. When the measuring time is within 100ms (10 × 10ms) and the range returns to be within 1,000, BFM4'bit4 will be set to 1 again. We recommend you check if the measured value is stable enough before operating it.

3) Zero detection function

Users can use this function to know whether the object has been removed from the load cell. If the BFM4'bit4 is 1, and the BFM4'bit0 and bit1 are 1 as well, the object has been removed from the load cell already, and you can proceed to the next step.

4) Filtering

This setting is used to exclude noises from the readings, which are introduced by environmental factors.

6. Example

1) Current state of weight



Read the current state BFM4. More information, please refer to [5.2](#)

2) Get current weight value



Write average weight value (BFM16) to D0

3) Calibrating weight

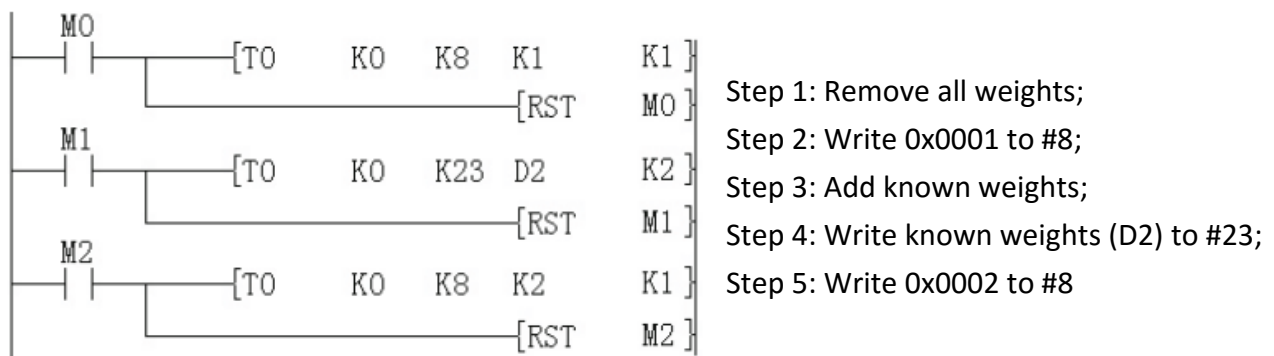

*In the new version, the step 1 can be used for manual reset.

Adjustment and calibration are to make sure the weight values of module and the heavy load units of module to be consistent.

4) Tare weight and gross weight

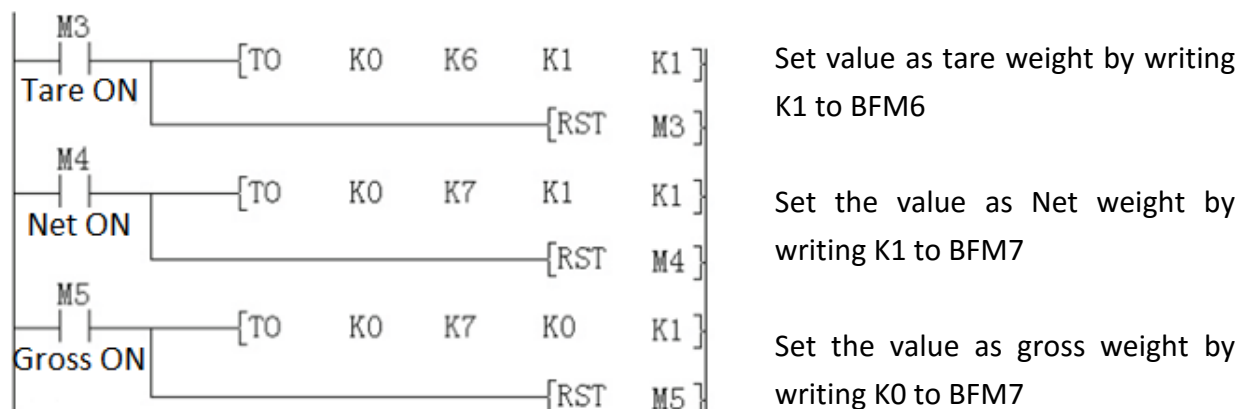

5) Filter method and strength

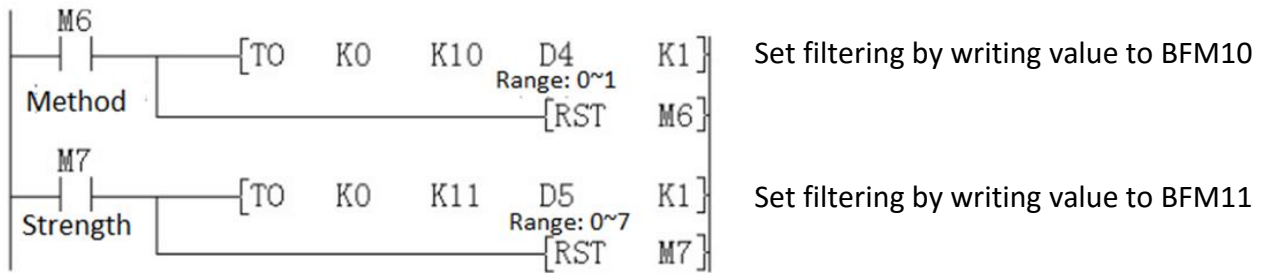

After setting the filtering mode and filtering strength, need to calibrate again.

6) Zero tracking

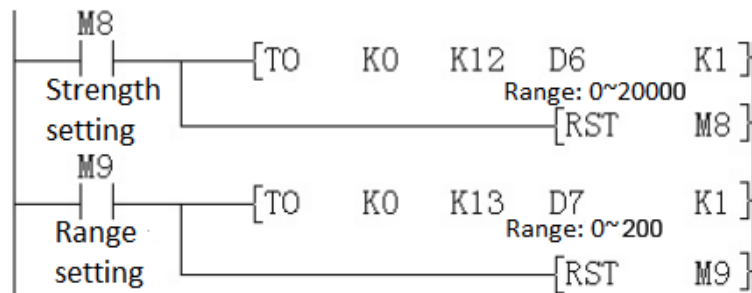

Zero tracking is used to reduce the temperature drift interference;

Set Zero Tracking Intensity to 0 to disable tracking. Set Zero Tracking Range to 0 to make it is unlimited.

7. Diagnosis

7.1 Check

- 1) Make sure all cables are connected properly;
- 2) Make sure all rules regarding LX3V expansion modules are met. Such as expansion modules other than digital inputs and outputs are no more than 8 in total. The total number of digital inputs and outputs are no greater than 256.
- 3) Make sure to select the correct operating range in application;
- 4) Make sure power supply is working properly;
- 5) LX3V CPU unit is in RUN mode;

7.2 Check the error

Check the following items, if LX3V-1WT-L does not work properly:

- 1) Check the LED state of power supply
ON: Expansion cable is properly connected.
OFF: Check the module connection cable
- 2) Check the wiring;
- 3) Check status of the 24 V power indicator lamps (LED) of the LX3V-1WT-L.
On: 24 VDC is supplied;
Off: Supply 24 VDC (+10%) to the LX3V-1WT-L or check power supply
- 4) Check the state of LED "COM"(on the right top corner of LX3V-1WT-L);
ON: communicating
OFF: Check the state of #5(error), any bit (b0 b1 b2) in #5 is ON, means communication failure, refer to [5.2](#) to find out the reason