



Wecon VD2 Series Servo Drive Manual (Full V2.3)

Website: <http://www.we-con.com.cn/en>

Phone: +86-0591-8786886

Date: June 25, 2023



Preface

This manual is applicable to Wecon VD2 Series absolute value servo drives (VD2 SA series). In order to use this series of servo drives correctly, please read this manual carefully in advance and save it for later use.

During use, if you have any doubts about the function and performance of this equipment, please contact our technicians for relevant assistance to use this equipment smoothly.

The company's products are constantly being improved and upgraded, and the contents of this manual are subject to change without notice.

This manual is suitable for introductory and use reference books for elementary and intermediate readers. At the same time, all interpretation rights of this manual belong to our company.

 CAUTION

The danger caused by failure to operate as required may result in serious injuries or even death.

 WARNING
--

The danger caused by failure to operate as required may result in moderate or minor injuries, and equipment damage.

User manual version history

Date	Version	Changes	Applicable models and firmware versions
2021.12	A1.0	First release version	VD2-0□□SA1G model: V1.10, V1.12 VD2F-0□□SA1P model: V1.00
2022.3	A1.1	Chapter 2 Updating the servo driver naming, updating motor model table. Chapter 3 Updating motor dimension drawing and dimension table Chapter 6 Add new section 6.6.4 "Speed Limit in Speed Mode", updating relevant parameter content for firmware upgrade Chapter 11 Add the description of the scope of application of the cable	VD2-0□□SA1G model: Add V1.13 VD2F-0□□SA1P model: Add V1.01 and V1.02
2022.4	A1.2	Chapter 2 Updating section 2.1 "Servo Drive Specifications" Chapter 4 Updating section 4.1 "Main Circuit Wiring", updating section 4.5 "Communication signal wiring" Chapter 5 Updating section 5.3.3 "Restore Factory Settings" process and instructions Chapter 6 Updating section 6.6 "Absolute value system" Chapter 7 Updating section 7.3 "Gain adjustment" renderings Chapter 8 Updating section 8.2.5 "Communication Example" Chapter 10 Updating section 10.2.2 "Fault and Warning Code Table", 10.2.3 add section 10.3 "Troubleshooting" Chapters 9 and 11 adjust relevant parameters for firmware upgrades	VD2-0□□SA1G model: Add V1.14 VD2F-0□□SA1P model: V1.01, V1.02 Add VD2-021TA1G model: V1.01
2022.11	V2.0	Chapter 4 Modify section 4.4.1 "VD2A, VD2F pin wiring diagram" Add section 4.4.1 "VD2-0xxSA1H driver DIDO pin distribution". Add section 4.4.2 "VD2-0xxSA1H mode wiring diagram" Add section 4.4.5 "VD2-0xxSA1H DIDO signal" Chapter 7 Updating section 7.3.4 "Model Tracking Control Function" Updating section 7.3.5 "Gain Switching Function" Updating section 7.4.3 "Low Frequency Vibration Suppression Function" Updating section 7.4.4 "Type A Vibration Suppression Function" Chapters 9 and 11 adjust relevant parameters for new functions such as "model tracking control"	VD2-0□□SA1H model: Add V1.17 firmware
2023.06	V2.1	Chapter 6 Updating section 6.17 "Shutdown deceleration time" setting feature. Updating section 6.63 "P10-6 Multi-turn Absolute Encoder Reset" and "P10-8: Multi-turn Absolute Encoder Origin Offset Compensation" Updating section 6.64 "P00-31 Encoder Read and Write Verification Abnormal Threshold Setting" Chapter 10 add "Er.43 Drive Overload Fail" and parameter content. Add "A80 Drive Overload Alarm" Modify "A91 Parameter Modification too Frequent Warning" trigger condition. Add temporary solution for "A93 encoder read and write verification abnormal frequency is too high" Chapters 9 and 11 adjust relevant parameters for new functions such as "Estop shutdown deceleration time"	Add V1.18 firmware
2024.01	V2.2	Chapter 2 Update 2.1.1 "Servo Drive Model Naming Rules" Add 2.1.1 "VD2L Drive Appearance and Nameplate" and "VD2C Drive Appearance and Nameplate" Add 2.1.2 "Composition of VD2L Drive" and "Composition of	Update V1.20 firmware Add VD2L series model Add VD2-050TA1G model

		<p>VD2C Drive Appearance"</p> <p>Add 2.1.3 "Electrical Specifications for VD2L Drives" and "Electrical Specifications for VD2C Drives"</p> <p>Add 2.2.2 "Motor (Wire Type) Composition Diagram"</p> <p>Chapter 3</p> <p>Add 3.1.1 "VD2L Drive Installation Dimension Diagram" and "VD2C Drive Installation Dimension Diagram"</p> <p>Add 3.1.4 "VD2L Drive Minimum Installation Dimension Diagram" and "VD2C Drive Minimum Installation Dimension Diagram"</p> <p>Add 3.1.4 "VD2L Drive Parallel Installation Dimension Diagram" and "VD2C Drive Parallel Installation Dimension Diagram"</p> <p>Chapter 4</p> <p>Add 4.1.1 "VD2L Servo Drive Main Circuit Terminal Arrangement and VD2C Servo Drive Main Circuit Terminal Arrangement"</p> <p>Add 4.1.2 "VD2L drive single-phase 220V main circuit wiring" and "VD2C drive single-phase 220V main circuit wiring"</p> <p>Add 4.3 "Absolute Encoder Cable Connector (Connector Type) Pin-out and Encoder Cable Pin Connection"</p> <p>Add 4.4.1 "Pin-out of VD2L servo drive control input and output (CN2 interface)"</p> <p>Add 4.4.1 "VD2L drive single phase 220V main circuit wiring"</p> <p>Add 4.4.2 "VD2L drive position pulse mode wiring"</p> <p>Add 4.4.3 "VD2L drive differential method"</p> <p>Add 4.4.3 "VD2L drive collector open circuit method"</p> <p>Add 4.4.5 "VD2L drive digital input circuit"</p> <p>Add 4.4.5 "VD2L drive digital output circuit"</p> <p>Add 4.5.1 "VD2L drive VD2L type and PC connection method"</p> <p>Chapter 6</p> <p>Revise 6.2 "P0-01 Parameter Table 6-11 Control Mode Parameter Details"</p> <p>Revise 6.2 "Table 6-15 Position Pulse Type Selection Parameter Details"</p> <p>Revise 6.2 "Add VD2L P0-14 parameters"</p> <p>Add 6.2.6 "VD2L-0xxSA1P pulse signal DO output function"</p> <p>Revise 6.2.6 "Comments on P6-28, P6-30 and P6-32"</p> <p>Revise 6.3.1 "Comments on supported models of P5-03, P5-04, P5-01 and P5-02"</p> <p>Revise 6.4.1 "Unsupported models for P1-07"</p> <p>Revise 6.4.1 "Table 6-45 AI_1 related parameter detail "</p> <p>Revise 6.4.3 "Comments on P1-14"</p> <p>Revise 6.4.3 "Comments on Table 6-52 Mixed Control Mode Parameters"</p> <p>Revise 6.6.4 "Functions of P0-30"</p> <p>Chapter 7</p> <p>Revise 7.4.3 "Applicable Models for Related Parameters of Low Frequency Vibration Suppression Function"</p> <p>Revise 7.4.4 "Applicable models for Related Parameters of Type A Vibration Suppression Function"</p> <p>Chapter 9</p> <p>Revise the function introduction for P0-30, and add the function of shielding encoder over temperature function, etc.</p> <p>Revise the value range of P10-4 and cancel the shielding overload protection function</p> <p>Add P10-11 function, enabling function of motor stall over temperature protection</p> <p>Add a note about the VD2L model not supporting some parameters.</p>	
--	--	--	--

		Add U0-49 motor overload internal count Chapter 10 Add the function introduction of ER.45 drive stall over temperature protection. Revise ER.27 Not clearable properties;	
--	--	---	--

The following table lists the servo driver models and supported firmware.

	Supported models	Corresponding model	Voltage	Supported firmware	
Wecon VD2SA series servo drives manual	VD2-010SA1G	VD2 A type	220V	V1.10	
	VD2-014SA1G			V1.12	
	VD2-016SA1G			V1.13	
	VD2-019SA1G	VD2 B type		V1.14	
	VD2-021SA1G			V1.15	
	VD2-025SA1GF			V1.16	
	VD2-030SA1G			V1.17	
	VD2F-003SA1P			VD2F	V1.18
	VD2F-010SA1P	V1.19			
	VD2F-014SA1P	V1.20			
		VD2L-010SA1P			VD2L
	VD2L-014SA1P				
	VD2-021TA1G	VD2 B type		380V	V1.01
	VD2-030TA1G	VD2 C type			V1.17
VD2-040TA1G	V1.18				
VD2-0250TA1G	V1.19				
				V1.20	

Contents

1.	Safety reminder	1
1.1	Safety precautions	1
1.2	Precautions for storage and transportation	2
1.3	Precautions during installation	2
1.4	Precautions during wiring	3
1.5	Precautions during operation	3
1.6	Precautions during maintenance and inspection	4
2.	Product Information	5
2.1	Servo drives	5
2.1.1	Servo drive model naming	5
2.1.2	The composition of servo drive	8
2.1.3	Specification of servo drive	12
2.2	Servo motors	15
2.2.1	Servo motor model naming	15
2.2.2	Composition of Servo motor	16
2.2.3	Specification of servo motor	17
3.	Installation of servo drive and motor	18
3.1	Installation of servo drive	18
3.1.1	Dimensions (Unit: mm)	18
3.1.2	Installation site	20
3.1.3	Installation environment	20
3.1.4	Installation matters	21
3.2	Installation of servo motor	26
3.2.1	Installation dimensions (Unit: mm)	26
3.2.2	Installation site	29
3.2.3	Installation environment	29
3.2.4	Installation precautions	30
4.	Wiring	31
4.1	Main circuit wiring	31
4.1.1	Main circuit terminals	31
4.1.2	Power wiring	37
4.1.3	Precautions for main circuit wiring	41
4.2	Power line connection of servo drive and servo motor	42
4.2.1	Power line	42
4.2.2	Brake device cable	42
4.3	Encoder cable connection of servo drive and servo motor	43
4.4	Servo drive control input and output wiring	48
4.4.1	CN2 pin distribution	48
4.4.2	Wiring diagram of each mode	51
4.4.3	Position instruction input signal	55
4.4.4	Analog input signal	57
4.4.5	Digital input and output signals	58
4.4.6	Brake wiring	65
4.5	Communication signal wiring	67

4.5.1	Communication connection with servo host computer (RS422)	68
4.5.2	Communication connection with PLC and other device (RS485)	70
5.	Panel	71
5.1	Panel composition	71
5.2	Panel display	71
5.2.1	Display switching	72
5.2.2	Status display	72
5.2.3	Parameter display	72
5.2.4	Fault display	74
5.2.5	Monitor display	75
5.3	Panel operation	76
5.3.1	Parameter setting	76
5.3.2	Jog operation	77
5.3.3	Factory reset	78
6.	Operation	79
6.1	Basic settings	79
6.1.1	Check before operation	79
6.1.2	Power-on	79
6.1.3	Jog operation	79
6.1.4	Rotation direction selection	80
6.1.5	Braking resistor	80
6.1.6	Servo operation	81
6.1.7	Servo shutdown	82
6.1.8	Brake device	86
6.2	Position control mode	90
6.2.1	Position instruction input setting	90
6.2.2	Electronic gear ratio	101
6.2.3	Position instruction filtering	103
6.2.4	Clearance of position deviation	104
6.2.5	Position-related DO output function	104
6.3	Speed control mode	110
6.3.1	Speed instruction input setting	110
6.3.2	Acceleration and deceleration time setting	114
6.3.3	Speed instruction limit	115
6.3.4	Zero-speed clamp function	116
6.3.5	Speed-related DO output function	116
6.4	Torque control mode	120
6.4.1	Torque instruction input setting	120
6.4.2	Torque instruction filtering	122
6.4.3	Torque instruction limit	122
6.4.4	Speed limit in torque mode	124
6.4.5	Torque-related DO output functions	124
6.5	Mixed control mode	126
6.6	Absolute system	127
6.6.1	Overview	127
6.6.2	Single-turn absolute value system	127

6.6.3	Multi-turn absolute value system	128
6.6.4	Related functions and parameters	129
6.6.5	Absolute value system encoder battery	130
6.7	Other functions	133
6.7.1	VDI	133
6.7.2	Port filtering time	134
6.7.3	VDO	135
6.7.4	Motor overload protection	136
7.	Adjustments	137
7.1	Overview	137
7.2	Inertia recognition	138
7.3	Gain adjustment	140
7.3.1	Automatic gain adjustment	140
7.3.2	Manual gain adjustment	142
7.3.3	Feedforward gain	144
7.3.4	Model Tracking Control Function	145
7.3.5	Gain switching	147
7.4	Mechanical resonance suppression	155
7.4.1	Mechanical resonance suppression methods	155
7.4.2	Notch filter	155
7.4.3	Low frequency vibration suppression	157
7.4.4	Type A vibration suppression	158
8.	Communication	160
8.1	Modbus communication	160
8.1.1	Hardware wiring	160
8.2	Modbus communication protocol analysis	161
8.2.1	Modbus data frame format	161
8.2.2	Description of supported function codes	161
8.2.3	CRC check	162
8.2.4	Error response frame	162
8.2.5	Communication example	162
8.3	Servo communication parameter setting	164
8.4	Modbus communication variable address and value	166
8.4.1	Variable address description	166
8.4.2	Variable value type description	166
8.4.3	Numerical unit description	166
9.	Parameters	168
Group P00	Basic settings	168
Group P01	Control parameters	173
Group P02	Gain adjustment	178
Group P03	Self-adjusting parameters	184
Group P04	Vibration suppression	186
Group P05	Signal input and output	190
Group P06	DI/DO configuration	194
Group P07	multi-segment position	197
Group P10	Accessibility	205

Group P12 Communication parameters	208
Group P13 Communication input and output terminal	209
Group U0 Universal monitoring	212
Group U1 Warning monitoring	219
Group U2 Device monitoring	221
10. Malfunctions	223
10.1 Faults and warnings handling at startup	223
10.1.1 Position control mode	223
10.1.2 Speed control mode	224
10.1.3 Torque control mode	226
10.2 Faults and warnings handling during operation	227
10.2.1 Overview	227
10.2.2 Fault and warning code table	228
10.3 Troubleshooting	231
11. Appendix	256
11.1 Lists of parameters	256
Group P00 Basic settings	257
Group P01 Control parameter	258
Group P02 Gain adjustment	260
Group P03 Self-adjustment parameters	261
Group P04 Vibration suppression	262
Group P05 Signal input and output	263
Group P06 DIDO configuration	264
Group P07 multi-segment position	266
Group P10 Accessibility	270
Group P12 Communication parameters	272
Group P13 Virtual input terminal	272
DI/DO channel function definition	273
Group U0 Monitoring parameters	275
Group U1 Warning monitoring	276
Group U2 Device monitoring	277
11.2 List of fault and warning codes	277
11.3 Wire	278

1. Safety

1.1 Safety precautions

This section describes the important items that users must observe, such as product confirmation, storage, transportation, installation, wiring, operation, inspection, and disposal. Please follow the steps required by this manual for trial operation.

WARNING

- ⚠ After the power is turned off for more than 5 minutes and the power indicator is off, use a multimeter to confirm that the voltage across the high-voltage capacitor has dropped to a safe voltage, and then proceed with the disassembly and assembly of the drive, otherwise the residual voltage may cause electric shock.
- ⚠ Please never touch the inside of the servo drive, otherwise it may cause electric shock.
- ⚠ Please insulate the connection part of the power terminal, otherwise it may cause electric shock.
- ⚠ The grounding terminal of the servo drive must be grounded, otherwise it may cause electric shock.
- ⚠ Please install the servo drive, servo motor, and external braking resistor on non-combustible materials, otherwise it may cause a fire.
- ⚠ Be sure to connect an electromagnetic contactor and a non-fuse circuit breaker between the power supply and the main circuit power supply of the servo drive. Otherwise, when the equipment fails, it may cause fire because it cannot cut off the large current.
- ⚠ In the servo drive and servo motor, please do not mix with oil, grease and other flammable foreign objects and screws, metal pieces and other conductive foreign objects, otherwise it may cause a fire.
- ⚠ When the servo motor is connected to the machine, if an operation error occurs, it will not only cause damage to the machine, but also sometimes cause personal safety accidents.
- ⚠ Do not damage or pull the cable forcefully, do not subject the cable to excessive force, or place heavy objects underneath, otherwise electric shock may occur, causing the product to stop operating or burn out.
- ⚠ Do not use the brake of the brake motor for normal braking, otherwise it may cause a malfunction.
- ⚠ Except for the designated operator, please do not set up, disassemble and repair the equipment, otherwise it may cause electric shock or injury.
- ⚠ Do not remove the cover, cables, connectors and optional accessories while the power is on, otherwise it may cause electric shock.
- ⚠ Please install a stop device on the machine side to ensure safety.
- ⚠ Please take measures to ensure that your personal safety will not be endangered when restarting, otherwise it may cause injury.
- ⚠ Do not modify this product, otherwise it may cause personal injury or mechanical damage.

1.2 Precautions for storage and transportation

CAUTION

- ☞ Please keep and install in the following environment:
- ☞ Places without direct sunlight;
- ☞ Places where the ambient temperature does not exceed product specifications;
- ☞ Places where the relative humidity does not exceed product specifications;
- ☞ Places where condensation will not occur due to rapid changes in temperature;
- ☞ Places free of corrosive gas and flammable gas;
- ☞ Places without combustible materials nearby;
- ☞ Places with less dust, salt and metal powder;
- ☞ Places where there is no splash of water, oil, medicine, etc.;
- ☞ Places where vibration or shock will not affect the product (places that exceed product specifications);
- ☞ Places that will not be exposed to radiation;
- ☞ Storage or installation in environments other than the above may cause product failure or damage:
- ☞ Please use the correct method for handling according to the weight of the product;
- ☞ Do not hold the motor cable or motor shaft for transportation;
- ☞ When operating the servo unit and servo motor, please pay attention to sharp parts such as the corners of the device.

1.3 Precautions during installation

CAUTION

- ☞ Do not install this product in a place where water will be splashed or in an environment prone to corrosion;
- ☞ Please be sure to comply with the devices of the installation direction, otherwise it may cause device failure;
- ☞ When installing, please make sure to keep the specified distance between the servo drive and the inner surface of the electric cabinet and other machines, otherwise it may cause fire or device failure;
- ☞ Do not apply excessive impact, otherwise it may cause equipment failure;
- ☞ Do not sit on the product or place heavy objects on it, otherwise it may cause personal injury;
- ☞ Do not use this product near flammable gases and combustibles, otherwise there may be a risk of electric shock or fire;
- ☞ Do not block the suction and exhaust ports, and do not allow foreign objects to enter the product, otherwise it may cause device failure or fire due to the aging of internal components.

1.4 Precautions during wiring

CAUTION

- ⊗ Do not connect the three-phase power supply to the output terminals U, V, W of the servo drive, otherwise it may damage the device or cause a fire;
- ⊗ Please connect the output U, V, W of the servo drive and the U, V, W of the servo motor directly. Do not use the electromagnetic contactor during the connection, otherwise it may cause abnormal operation or malfunction of the device;
- ⊗ When the DO output terminals are connected to the relay, please pay attention to the polarity of the freewheeling diode, otherwise the drive may be damaged and the signal cannot be output normally;
- ⊗ Please fix the power terminal and the motor terminal firmly, otherwise it may cause a fire hazard;
- ⊗ Do not connect the 220V servo unit directly to the 380V power supply;
- ⊗ Do not pass the power line and signal line through the same pipe or bundle them together. When wiring, the power line and signal line should be separated by more than 30cm;
- ⊗ Use twisted-pair shielded cables for signal cables and encoder cables, and the shielding layer should be grounded at both ends;
- ⊗ The wiring length of the signal input line is recommended to be within 3M, and the wiring length of the encoder is recommended to be within 15M;
- ⊗ When using in the following places, please take adequate shielding measures.
- ⊗ When interference occurs due to static electricity.
- ⊗ Places where strong electric or magnetic fields are generated;
- ⊗ Places where there may be radiation;
- ⊗ When checking the status, please make sure that the CHARGE indicator is off.

1.5 Precautions during operation

CAUTION

- ⊗ During trial operation, in order to prevent accidents, please run the servo motor without load (not connected to the drive shaft), otherwise it may cause injury.
- ⊗ When the servo motor is running, do not touch its rotating part, otherwise it may cause injury.
- ⊗ Be sure to set the correct moment of inertia ratio, otherwise it may cause vibration.
- ⊗ When it is installed on the supporting machine and starts to run, please set the user parameters in accordance with the machine in advance. If you start running without setting parameters, it may cause the machine to lose control or malfunction.
- ⊗ When installing on the supporting machinery and starting to run, please put the servo motor in a state where it can be stopped in an emergency at any time, otherwise you may get injured.
- ⊗ When using a servo motor on a vertical axis, please install a safety device to prevent the workpiece from falling under alarm, overtravel, etc. states. In addition, please set the servo lock stop setting when the overtravel occurs, otherwise the workpiece may fall in the overtravel state.
- ⊗ Since extreme user parameter adjustments and setting changes will cause the servo system to become unstable, please never make settings, otherwise it may cause injury.

- ☞ When an alarm occurs, reset the alarm after removing the cause and ensuring safety, and restart the operation, otherwise it may cause injury.
- ☞ Except for special purposes, do not change the maximum speed value (P1-10). If you change it carelessly, it may damage the machine or cause injury.
- ☞ When the power is turned on and within a period of time after the power is cut off, the heat sink of the servo drive, the external braking resistor, the servo motor, etc. may experience high temperature. Please do not touch it, otherwise it may cause burns.
- ☞ If the power supply is restored after an instantaneous power failure occurs during operation, the machine may restart suddenly, so please do not approach the machine, and press the stop button when the power is off, and operate after the power supply is stable.

1.6 Precautions during maintenance and inspection

CAUTION

- ☞ The power on and off operation should be carried out by professional operators.
- ☞ When testing the insulation resistance of the drive, please cut off all the connections with the drive first, otherwise it may cause the drive to malfunction.
- ☞ Do not use gasoline, alcohol, acid and alkaline detergents to avoid discoloration or damage to the casing.
- ☞ When replacing the servo drive, please transfer the user parameters of the servo drive to the new servo drive before restarting operation, otherwise the machine may be damaged.
- ☞ Do not change the wiring when the power is on, otherwise it may cause electric shock or injury.
- ☞ Do not disassemble the servo motor, otherwise it may cause electric shock or injury.

2. Product Information

2.1 Servo drives

2.1.1 Servo drive model naming

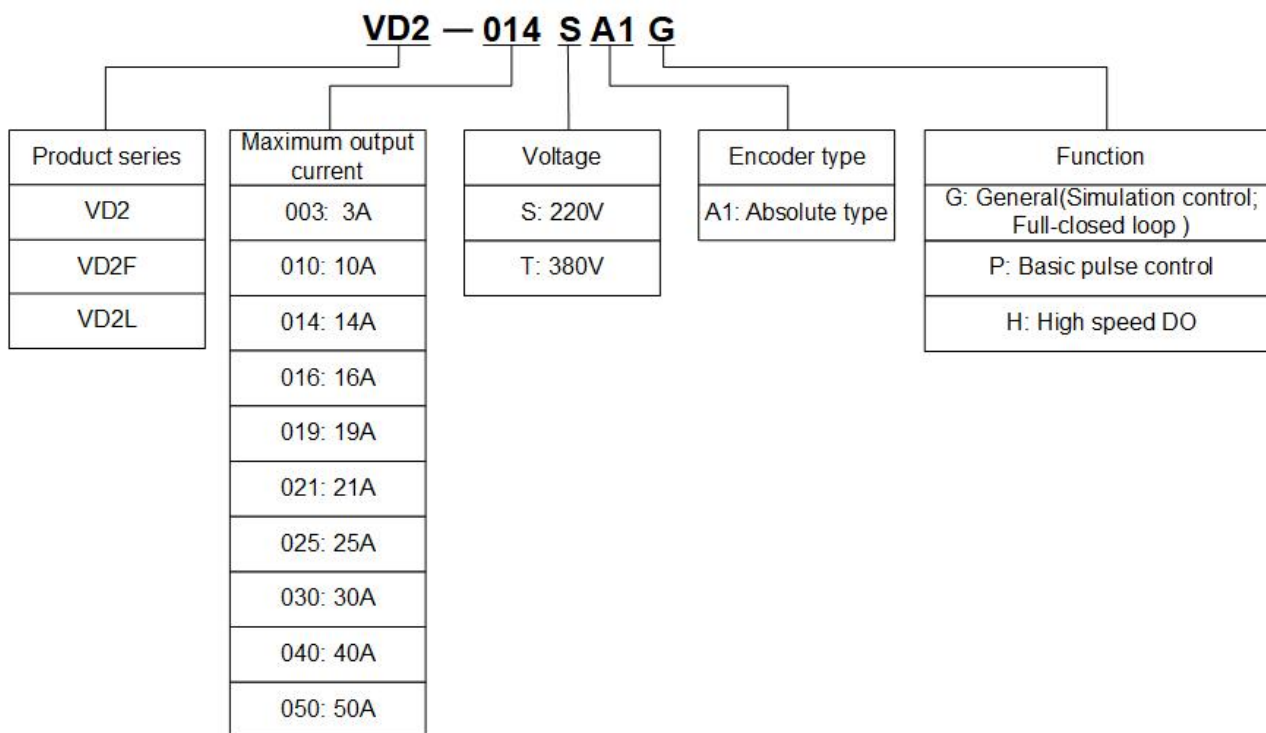

Figure 2-1 Servo drive model

Figure 2-2 (VD2A) and Figure 2-3 (VD2B) show the exterior and nameplate of the VD2 series absolute value servo drive.

Figure 2-4 shows the exterior and nameplate of the VD2F series absolute value servo drive.

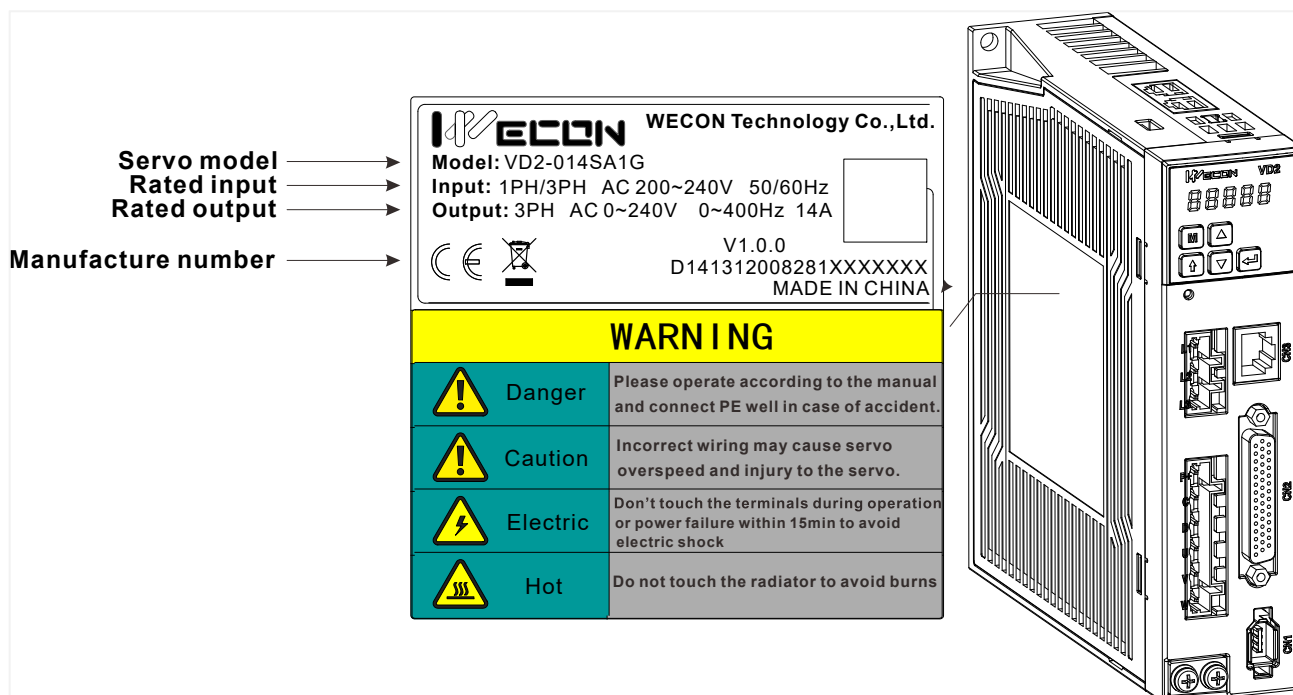

Figure 2-2 Exterior and nameplate of VD2A servo drive

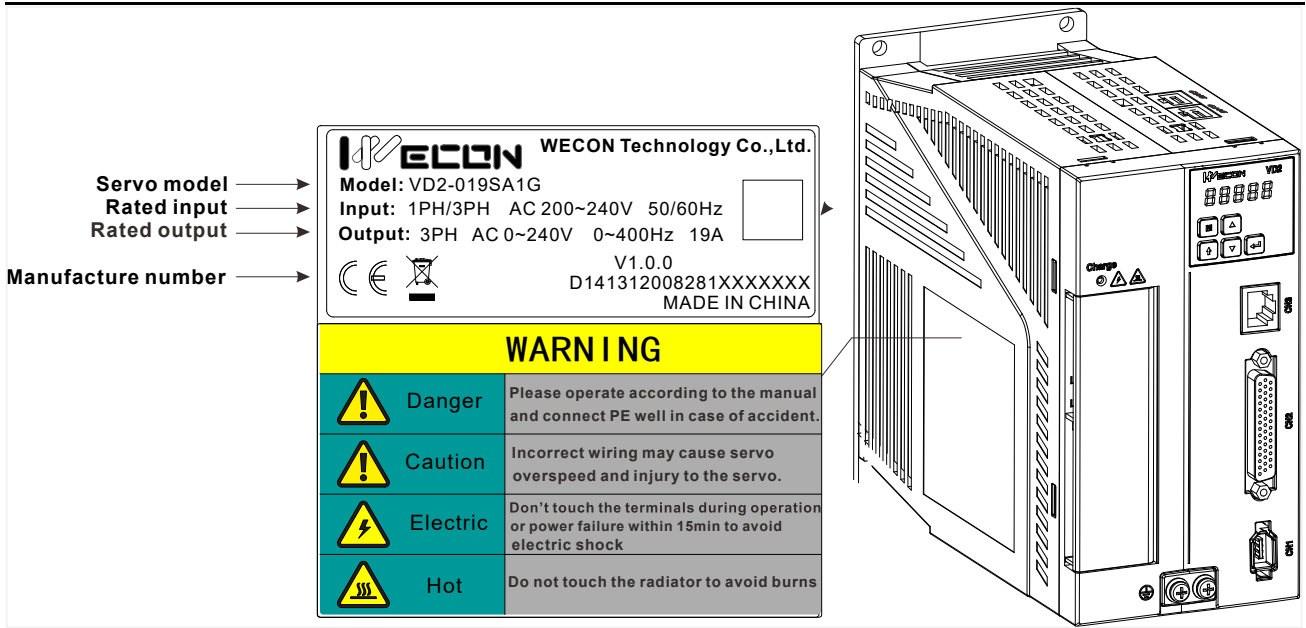

Figure 2-3 Exterior and nameplate of VD2B servo drive

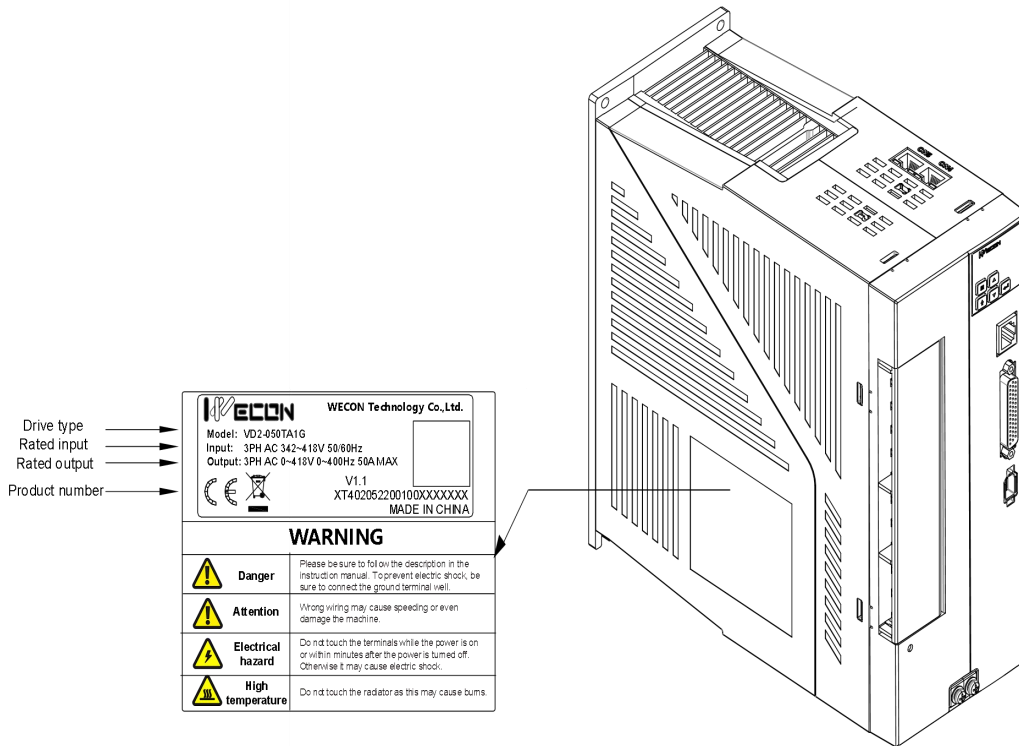

Figure 2-4 Exterior and nameplate of VD2C servo drive

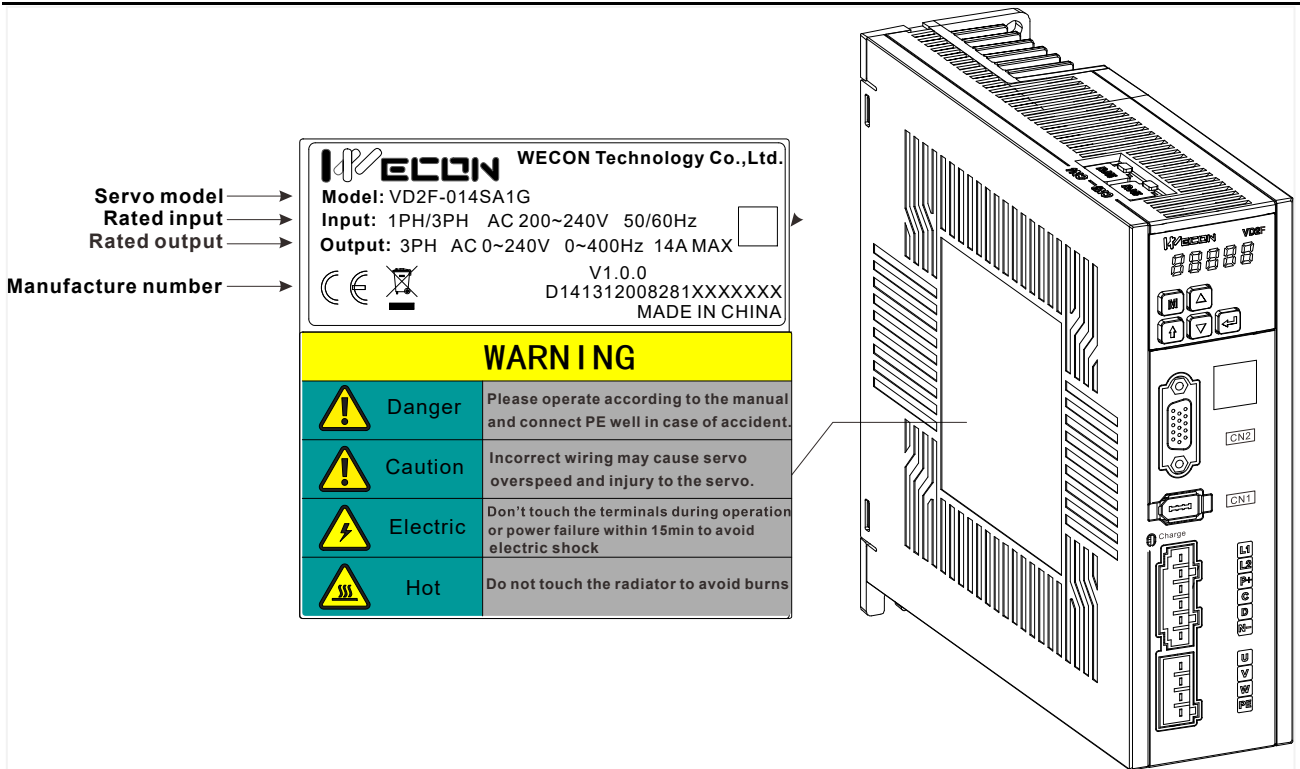

Figure 2-5 Exterior and nameplate of VD2F servo drive

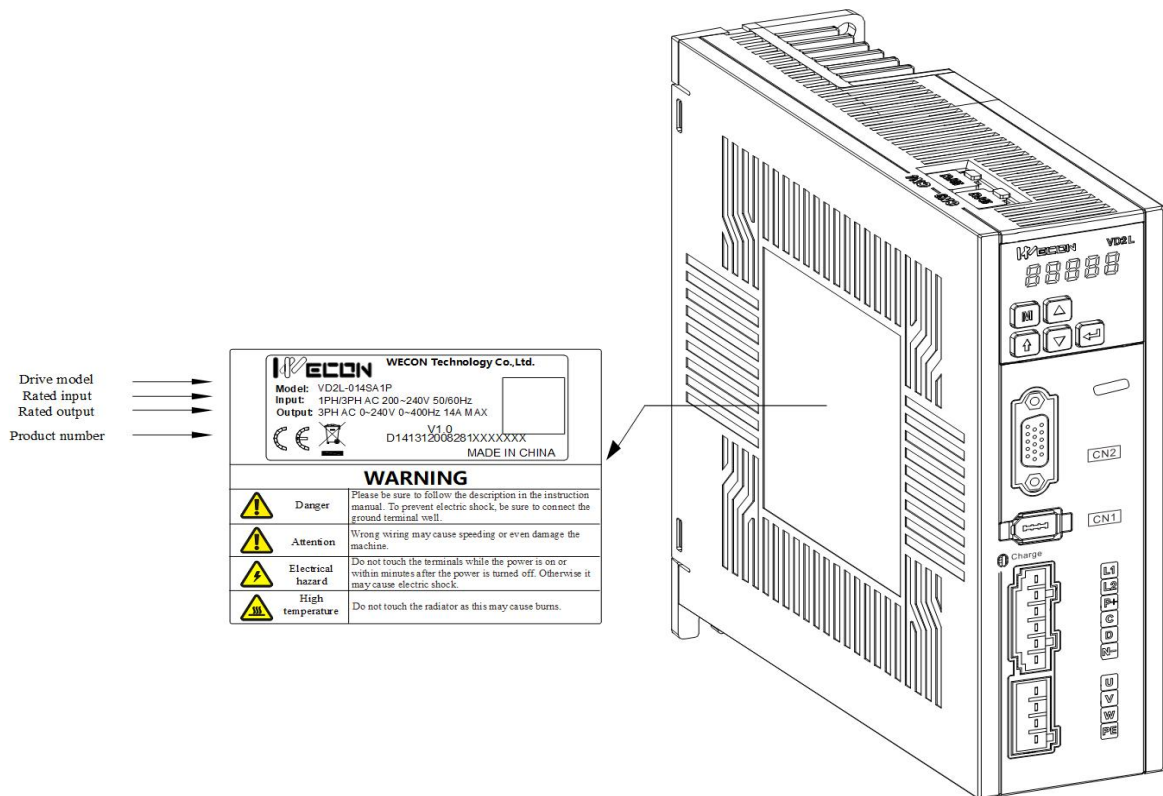

Figure 2-6 Exterior and nameplate of VD2L servo drive

2.1.2 The composition of servo drive

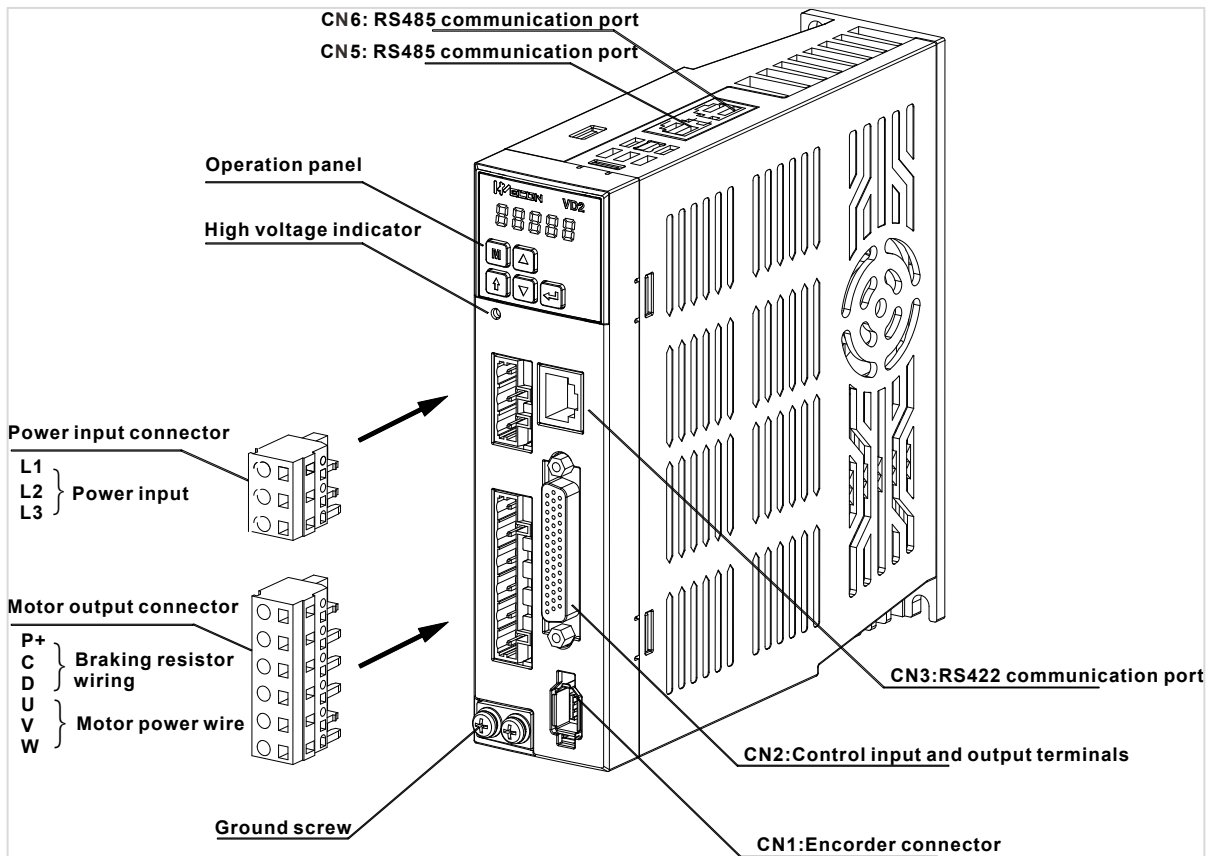

Figure 2-7 Composition of VD2A servo drive

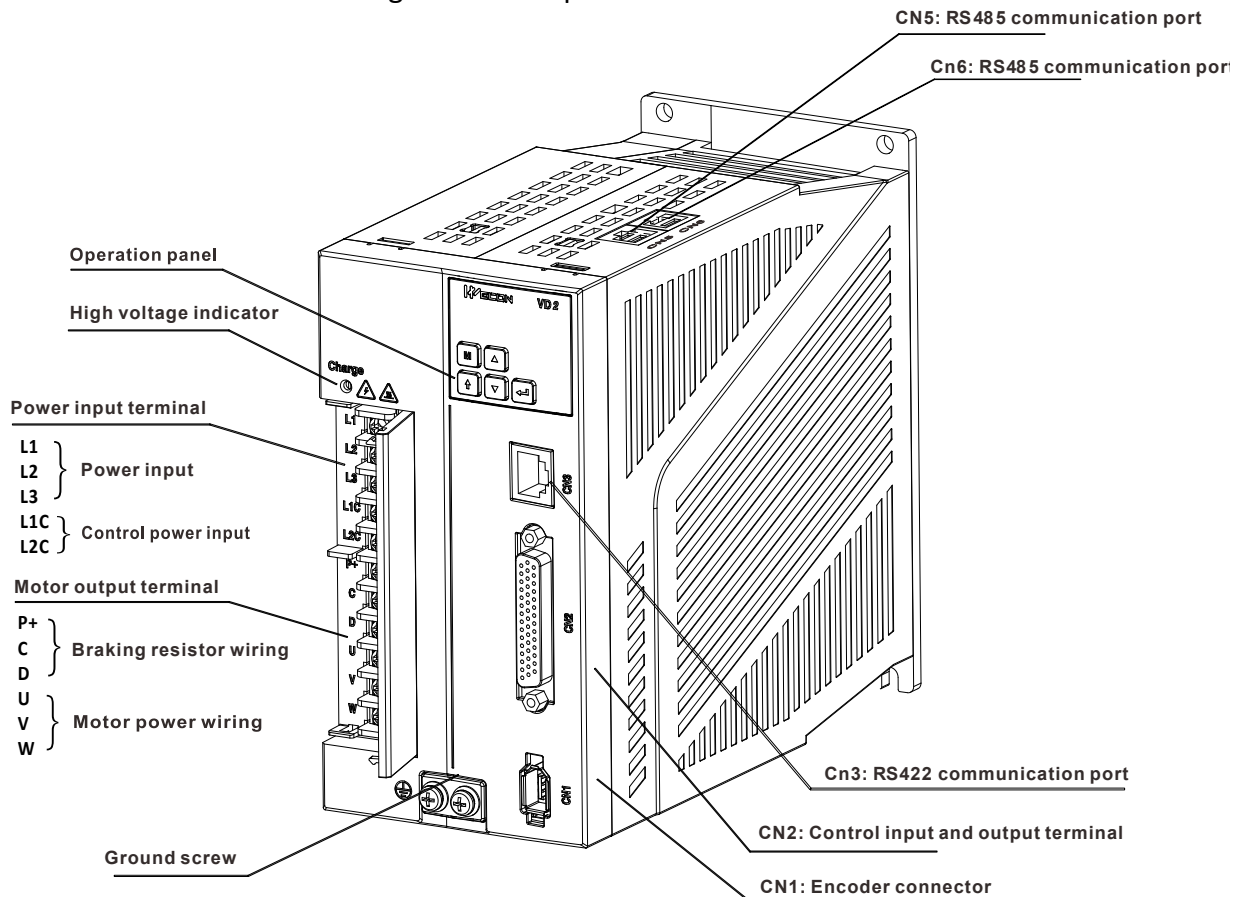

Figure 2-8 Composition of VD2B servo drive

The 220V power supply specifications and 380V power supply specifications of the VD2B drive have the same appearance and composition.

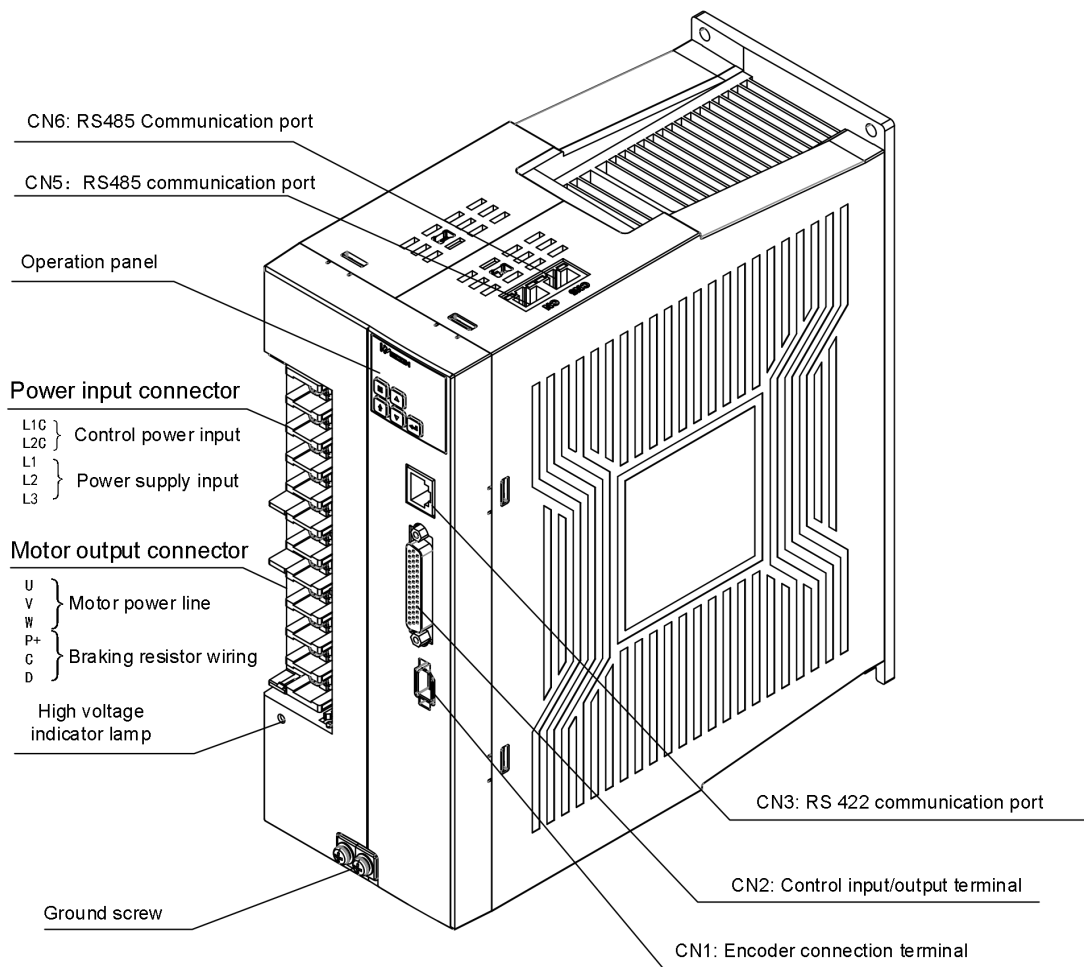

Figure 2-9 Composition of VD2C servo drive

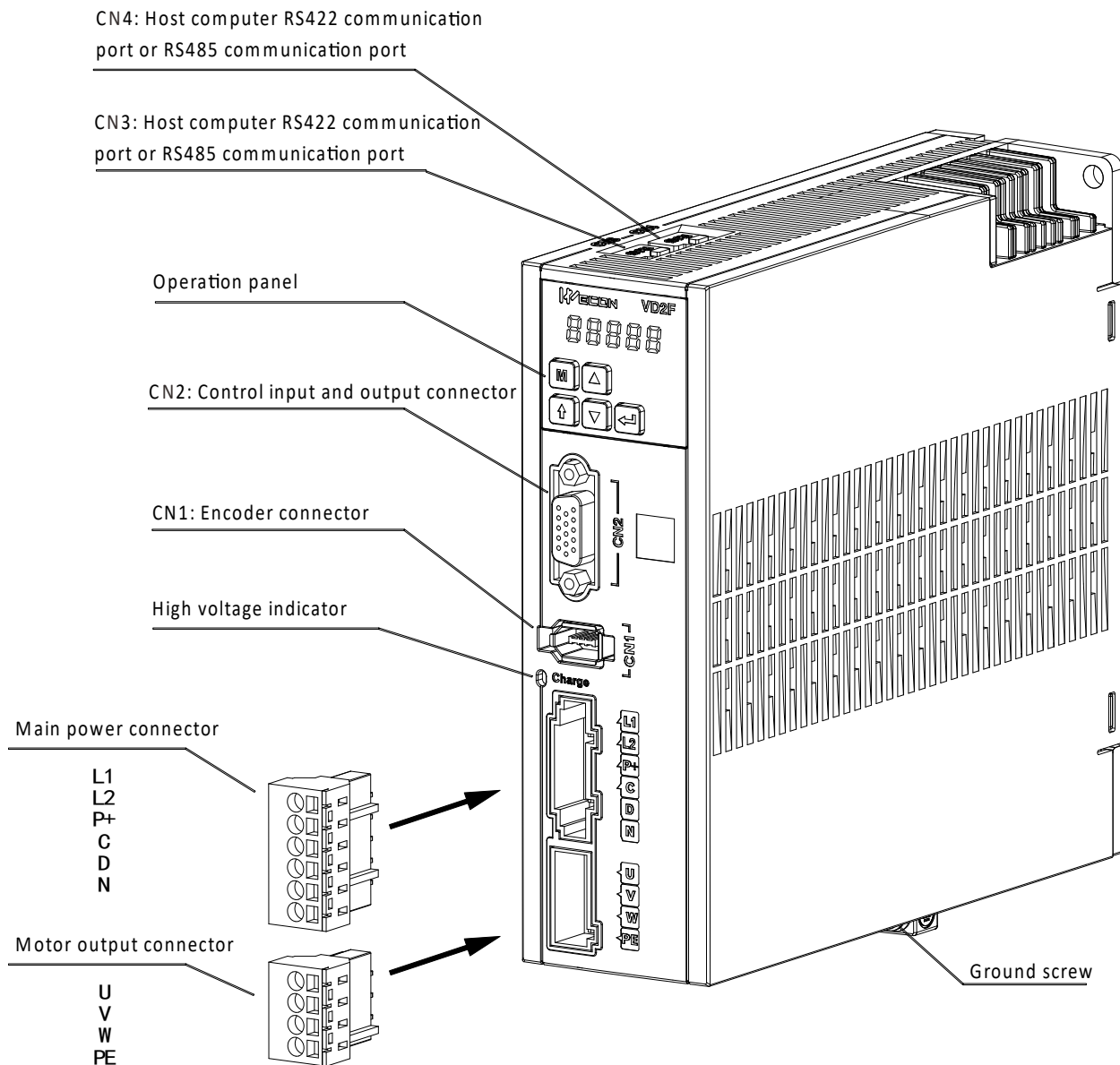

Figure 2-10 Composition of VD2F servo drive

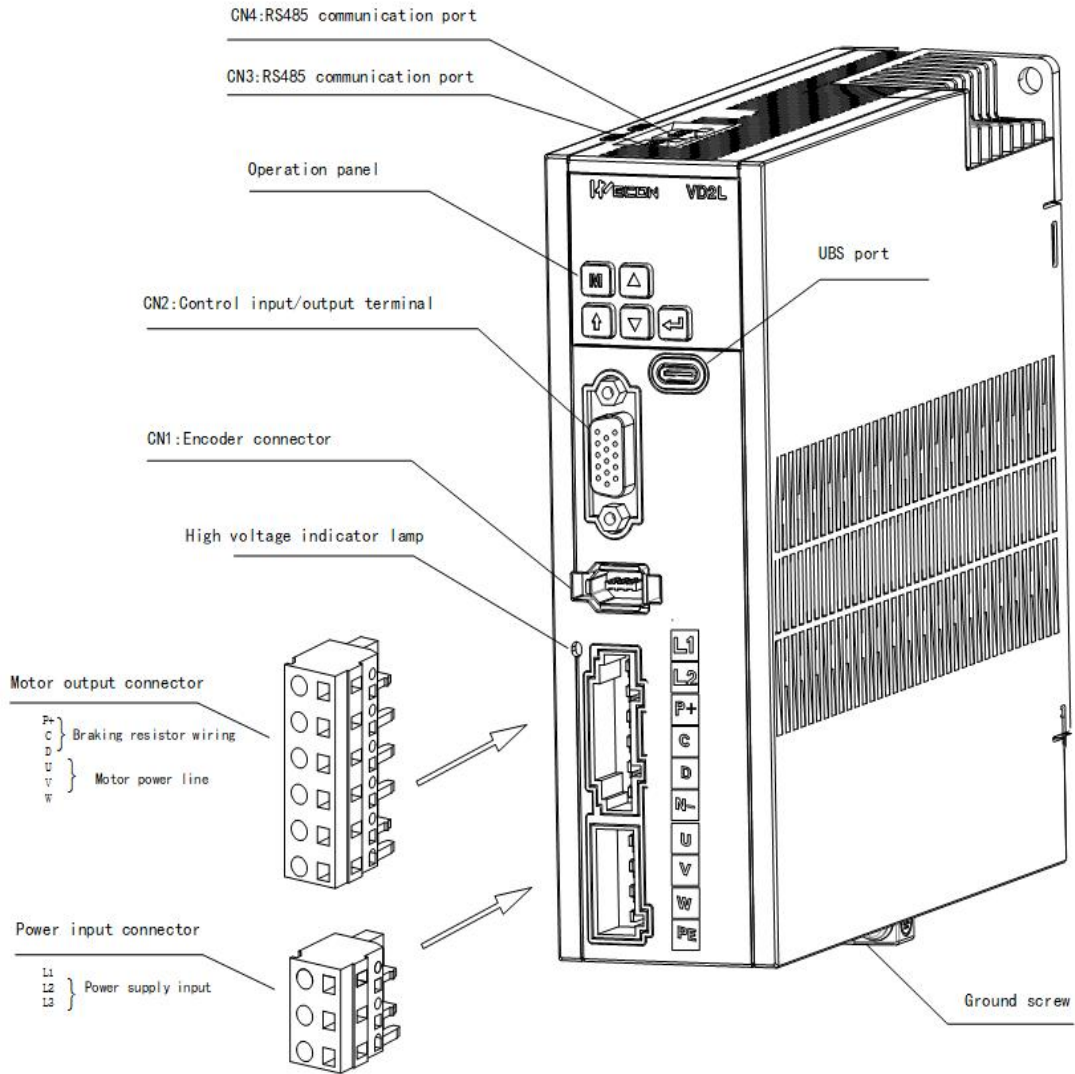

Figure 2-11 Composition of VD2L servo drive

Note: When using external braking resistor or internal braking resistor, special short-circuit processing is required, as shown in the figure below:

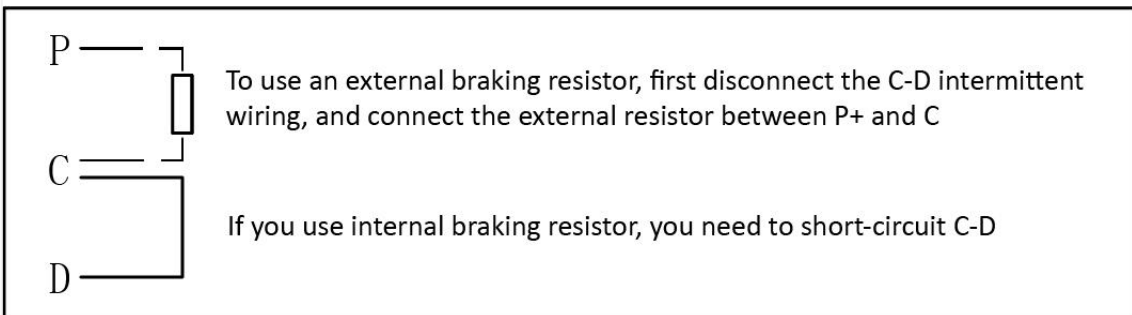

Figure 2-12 Short connection of braking resistor

2.1.3 Specifications of servo drive

Electrical specifications

Table 2-1 Electrical specifications of single phase 220V Servo drive

Item	VD2A		VD2B	
Model	VD2-010SA1G	VD2-014SA1G	VD2-016SA1G	VD2-019SA1G
Maximum output current	10A	14A	16A	19A
Control power supply	-		Single-phase AC 198 to 242V 50/60Hz	
Power supply	Single-phase AC 198 to 242V, 50/60Hz		Single-phase/Three phase AC 198 to 242V, 50/60Hz	
Braking resistor	External	Built-in and external	Built-in and external	

Table 2-2 Electrical specification of single-phase 220V servo drive

Item	VD2F		
Model	VD2F-003SA1P	VD2F-010SA1P	VD2F-014SA1P
Maximum output current	3A	10A	14A
Control power supply	-		
Power supply	Single-phase AC 198 to 242V, 50/60Hz		
Braking resistor	External		Built-in and external

Table 2-3 Electrical specification of three-phase 220V servo drive

Item	VD2-0xxSA1H			
Model	VD2-010SA1G	VD2-014SA1G	VD2-016SA1G	VD2-019SA1G
Maximum output current	10A	14A	16A	19A
Control power supply	-		Single-phase AC 198 to 242V, 50/60Hz	
Power supply	Single-phase AC 198 to 242V, 50/60Hz		Single-phase/Three phase AC 198 to 242V 50/60Hz	
Braking resistor	External	Built-in and external	External and built-in and external	

Table 2-4 Electrical specification of three-phase 380V servo drive

Item	VD2L-0xxSA1P/D	
Model	VD2L-010SA1P	VD2L-014SA1P/ VD2L-014SA1D
Maximum output current	10A	14A
Control power supply	-	
Power supply	Single-phase AC 198 to 242V, 50/60Hz	
Braking resistor	External	External and built-in and external

Table 2-5 Electrical specification of three-phase 220V servo drive

Item	VD2 B		
Model	VD2-021SA1G	VD2F-025SA1G	VD2F-030SA1G
Maximum output current	21A	25A	30A

Control power supply	Single-phase AC 198 to 242V, 50/60Hz
Power supply	Three-phase AC 198 to 242V, 50/60Hz
Braking resistor	Built-in and external

Table 2-6 Electrical specification of three-phase 220V servo drive

Item	VD2-0xxSA1H
Model	VD2-021SA1H
Maximum output current	21A
Control power supply	Single-phase AC 342 to 440V, 50/60Hz
Power supply	Three-phase AC 342 to 440V, 50/60Hz
Braking resistor	External and built-in and external

Table 2-7 Electrical specification of three-phase 380V servo drive

Item	VD2 C		
Model	VD2-030TA1G	VD2-040TA1G	VD2-050TA1G
Maximum output current	30A	40A	50A
Control power supply	Single-phase AC 342V to 440V, 50/60Hz		
Power supply	Three-phase AC 342V to 440V, 50/60Hz		
Braking resistor	Built-in and external		

Table 2-8 Electrical specification of three-phase 380V servo drive

Item	VD2 B		
Model	VD2-016TA1G	VD2-019TA1G	VD2-021TA1G
Maximum output current	16A	19A	21A
Control power supply	Single-phase AC 342V to 440V, 50/60Hz		
Power supply	Three-phase AC 342V to 440V, 50/60Hz		
Braking resistor	Built-in and external		

Basic specifications

Item		Specification	
Environment	Usage	Temperature	0°C to 40°C
		Humidity	5% to 95% (no condensation)
		Shock	3M4, 3mm (2 to 9Hz), Class 1 area
		Vibration	3M4, 1G (9 to 200Hz), Class 1 area
	Storage	Temperature	-25°C to 70°C
		Humidity	5% to 95% (no condensation)
		Vibration	2M2, 3.5mm (2 to 9Hz)
	Protection		IP10
	Circumstance		Places with no corrosive gas, flammable gas, combustible materials nearby; splash of water, oil, medicine and less dust, salt and

			metal powder.
I/O signal	Digital input (DI) signal		Up to 8 DI channels supported (only 4 DI channels for VD2F model). The supported DI functions are servo enable, fault clear and alarm, forward drive prohibition, reverse drive prohibition, zero speed bit, deviation counter clear, instruction reversal, emergency stop, electronic gear ratio switch, gain switch, instruction pulse input prohibition, internal speed instruction selection, mixed mode selection, internal multi-segment position enable signal and internal multi-segment position segment selection.
	Digital output (DO) signal		Up to 4 DO channels supported. The supported DO functions are servo ready, fault signal, warning signal, rotation detection, zero speed signal, positioning completion, positioning approach, speed consistence, speed approach, torque arrival, torque limiting, speed limiting, brake output, servo on state output, Z pulse output and communication VDO output.
Debug Interface	RJ45		RS485 and RS422
Position control mode	Input signal	Pulse instruction	Input pulse form: direction + pulse, CW/CCW, AB phase quadrature pulse
			Input form: differential input, open collector
			Input pulse frequency: differential input up to 500KHz; open collector up to 200KHz.
	Internal multi-segment position instruction selection	Configure 4 DI ports for INPOS1, INPOS2, INPOS3, and INPOS4 to select positions in segments 1 to 16	
Position output	Output form	A phase, B phase, Z phase	
Speed control mode	External instruction	Analog voltage	DC±10V, resolution 12 bits
	Internal instruction	Internal multi-segment speed instruction selection.	Configure 3 DI ports for INPOS1, INPOS2, INPOS3, and INPOS4 to select speed in segments 1 to 16
Torque control mode	External instruction	External instruction	DC±10V, resolution 12 bits
	Internal instruction	Internal instruction	Support torque instruction values -300% to 300%

2.2 Servo motors

2.2.1 Servo motor model naming

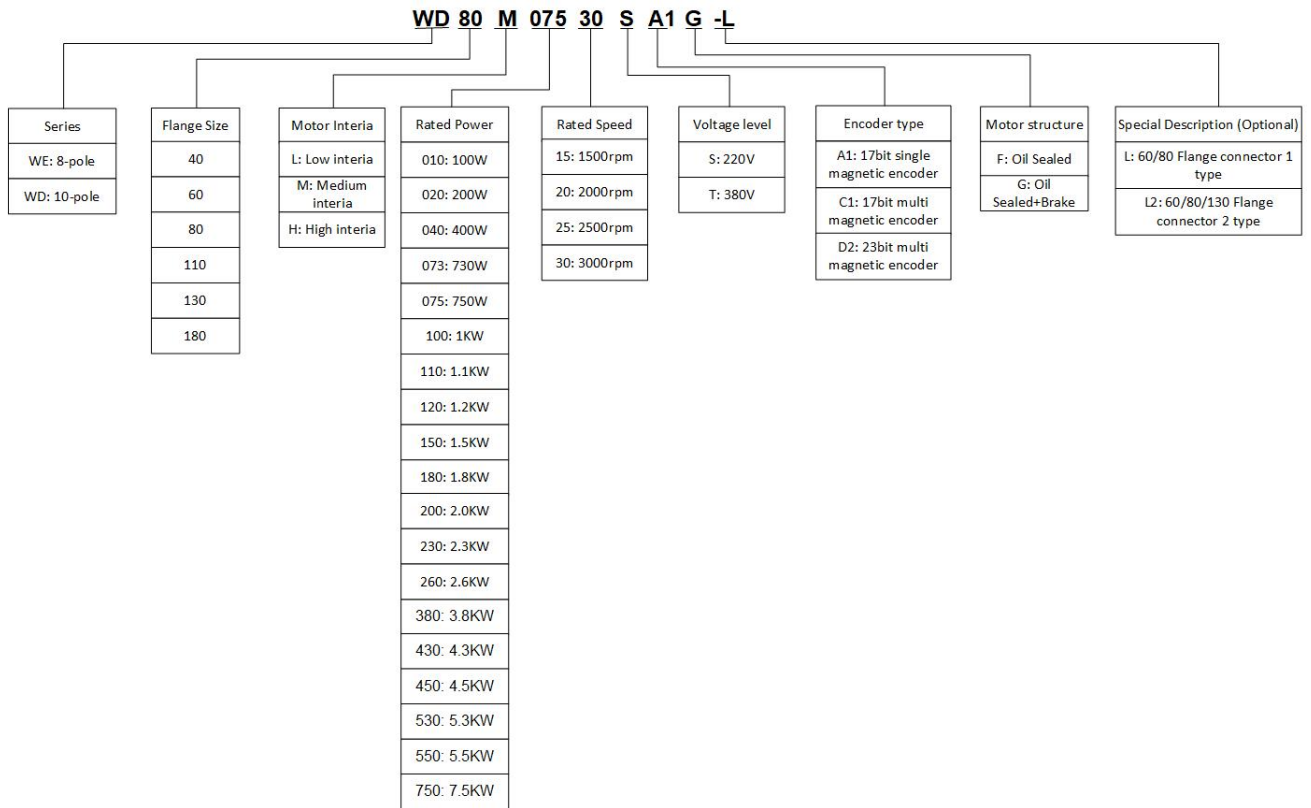

Figure 2-13 Servo motor naming

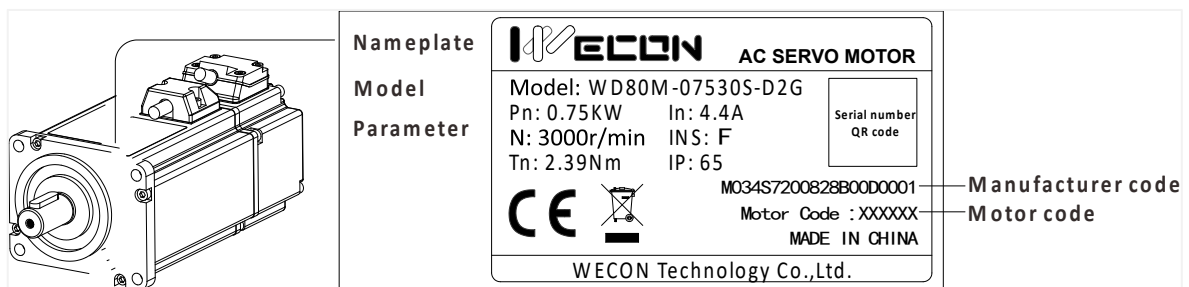

Figure 2-14 Servo motor nameplate

2.2.2 Composition of Servo motor

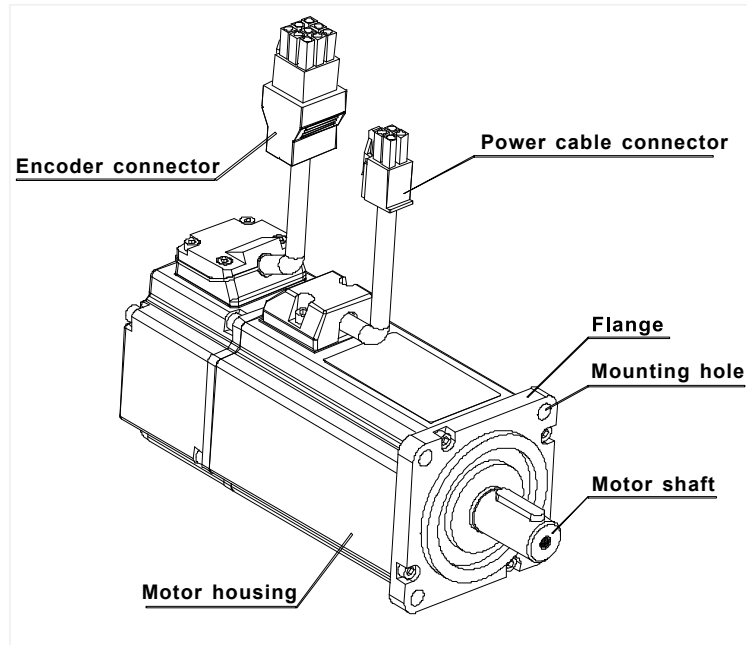

Figure 2-15 Motor (Wire type) composition of 40/60/80 flange

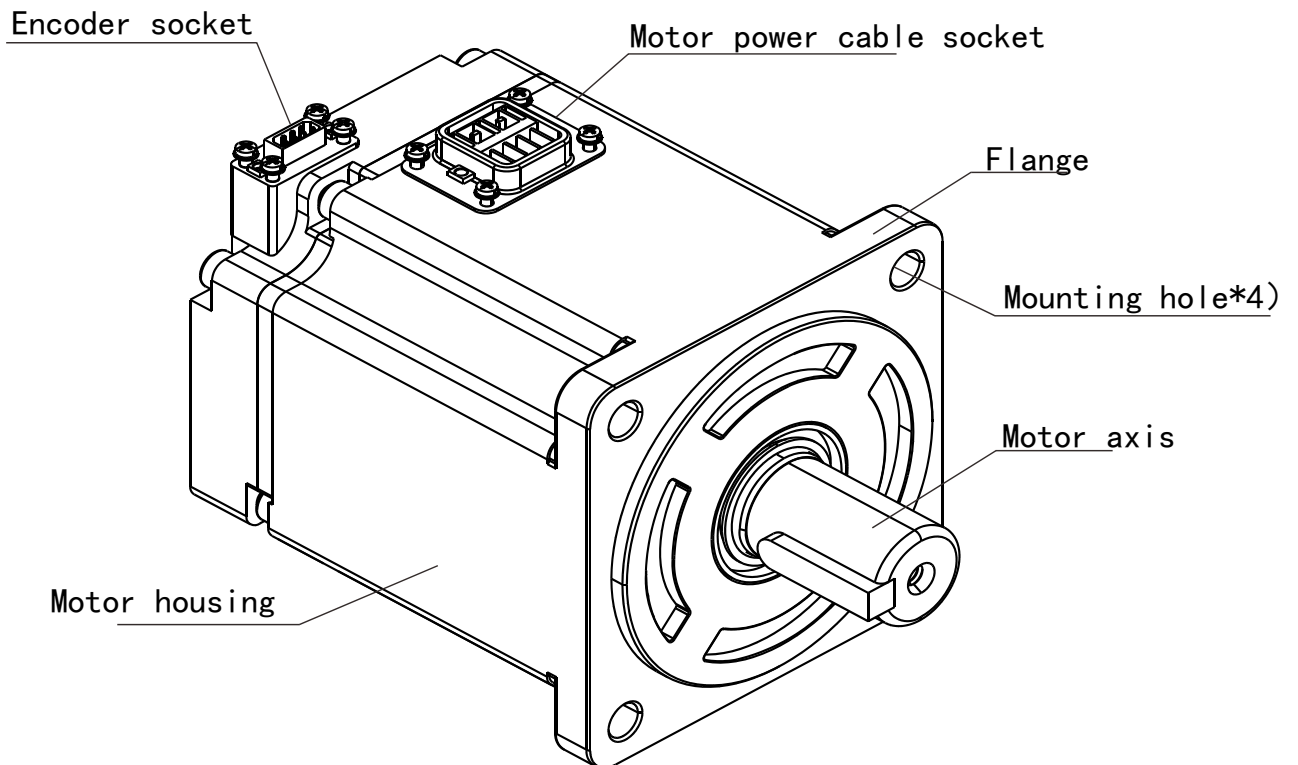

Figure 2-16 Motor (Connector type) composition of 40/60/80 flange

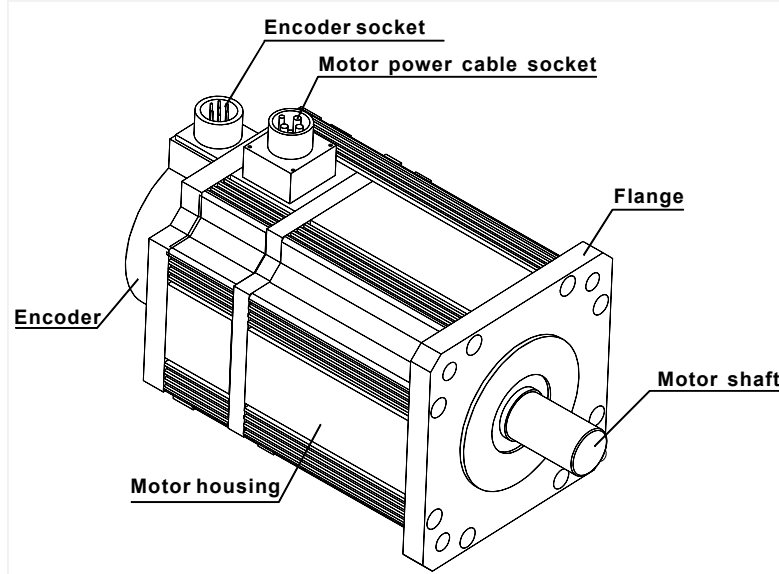

Figure 2-17 Motor composition of 110, 130 and 180 flange

2.2.3 Specifications of servo motor

Wecon motor model	Motor code	Flange size	Rated power (kW)	Rated torque (N.m)	Voltage (V)	Rated speed (rpm)	Encoder type	Brake
WE130M-10025S-A1F	A091	130	1.0	4.0	220	2500	17-bit single turn absolute magnetic	No
WE130M-15025S-A1G	A111	130	1.5	6.0	220	2500	17-bit single turn absolute magnetic	Yes
WE130M-26025S-C1F	C191	130	2.6	10	220	2500	17-bit multi turn absolute magnetic	No
WE80M-12030S-C1G	C231	80	1.2	4.0	220	3000	17-bit multi turn absolute magnetic	Yes
WE110M-18030S-D2G	D131	110	1.8	6.0	220	3000	23-bit multi turn absolute optical	Yes
WE130M-23015S-D2F	D161	130	2.3	15.0	220	1500	23-bit multi turn absolute optical	No

Table 2-9 Wecon Motor Specifications

Note: Only part of motor models is displayed. Please refer to the “Model Selection Manual” for details.

3. Installation of servo drive and motor

3.1 Installation of servo drive

3.1.1 Dimensions (Unit: mm)

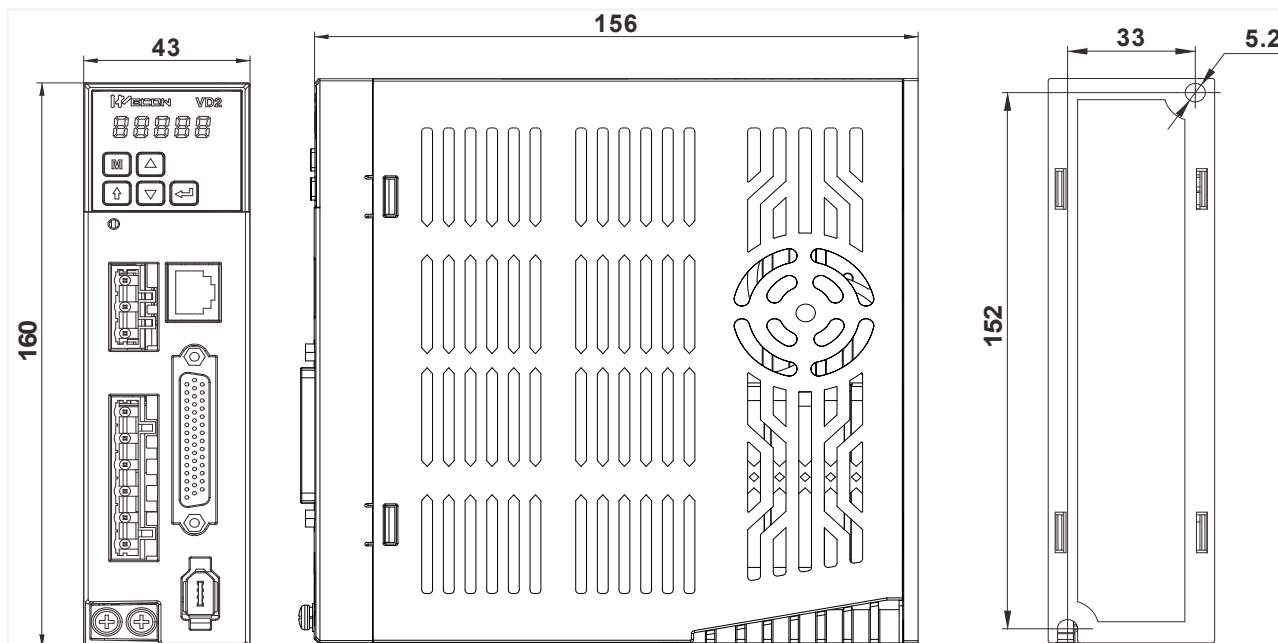

Figure 3-1 Installation dimensions of VD2A servo drive

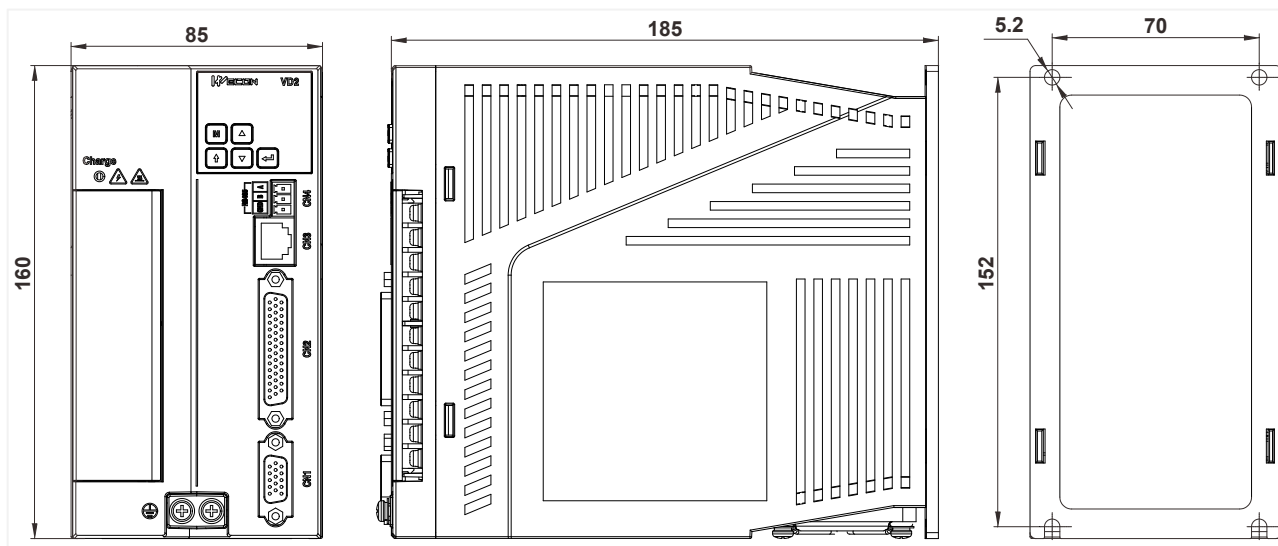

Figure 3-2 Installation dimensions of VD2B servo drive

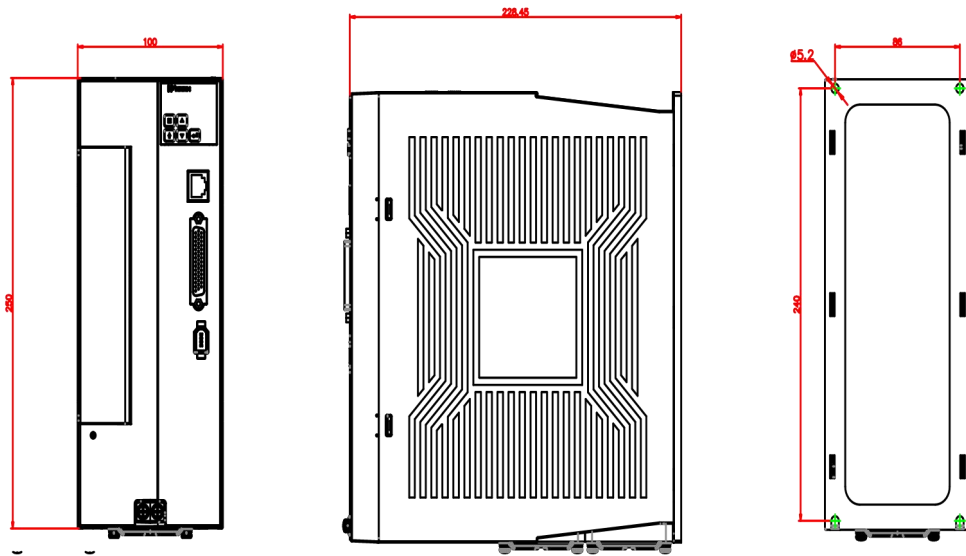

Figure 3-3 Installation dimensions of VD2C servo drive

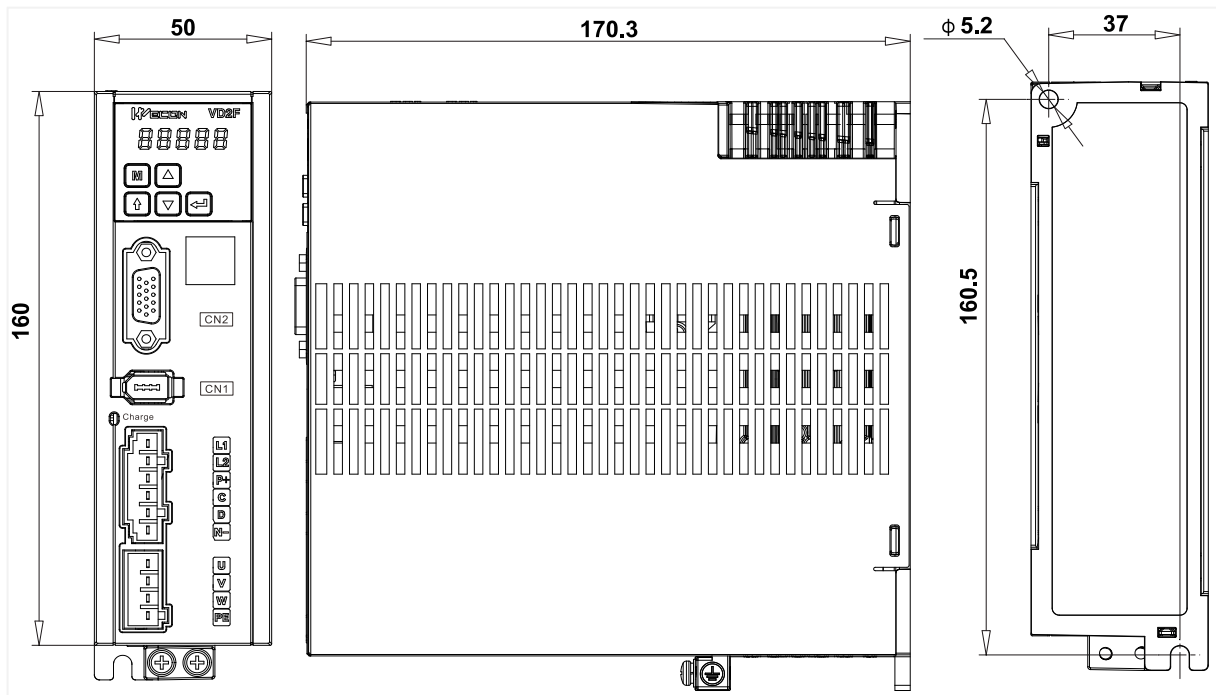

Figure 3-4 Installation dimensions of VD2F servo drive

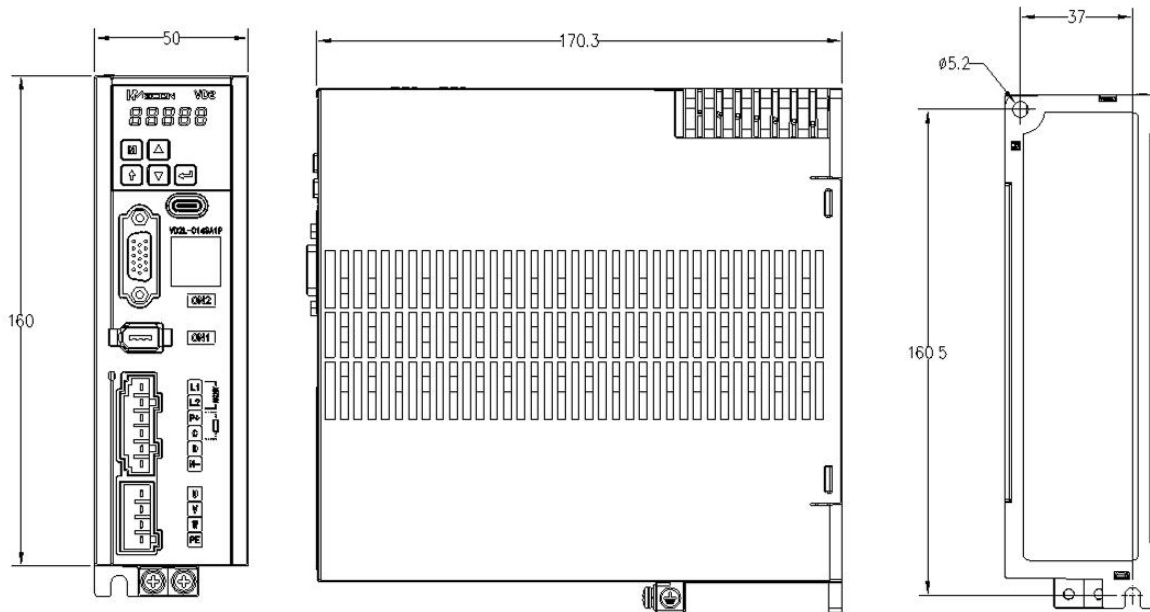

Figure 3-5 Installation dimensions of VD2L servo drive

3.1.2 Installation site

- ① Please install it in an installation cabinet free from sunlight and rain;
- ② In a place without vibration;
- ③ Please do not install in the environment of high temperature, humidity, dust and metal dust;
- ④ Do not use this product near corrosive and flammable gases such as hydrogen sulfide, chlorine, ammonia, sulfur, chlorinated gas, acid, alkali, salt, etc., or combustible materials.

3.1.3 Installation environment

The installation environment of the servo drive has a direct impact on the normal function of it and its service life. Therefore, the installation environment of servo drive must meet the following conditions:

Item	Specification
Ambient temperature	-10°C to 40°C (no freezing)
Ambient humidity	-20% to 90%RH (no condensation)
Storage temperature	-20°C to 60°C
Storage humidity	-20% to 90%RH (no condensation)
Protection grade	IP65
Vibration	Less than 0.5G (4.9m/s ²), 10 to 60Hz (non-continuous operation)
Power Systems	TN system*

Note:

The neutral point of the power system is directly connected to the ground, and the exposed metal components are connected to the ground through a protective grounding conductor.

3.1.4 Installation matters

(1) Installation specifications

In order to achieve a good cooling cycle effect, ensure that there is enough ventilation space around it when installing the servo drive, and be sure to comply with the installation standards in the control cabinet shown in the figure below, otherwise it may cause the drive to malfunction. For typical minimum installation dimensions, please refer to Figure 3-4.

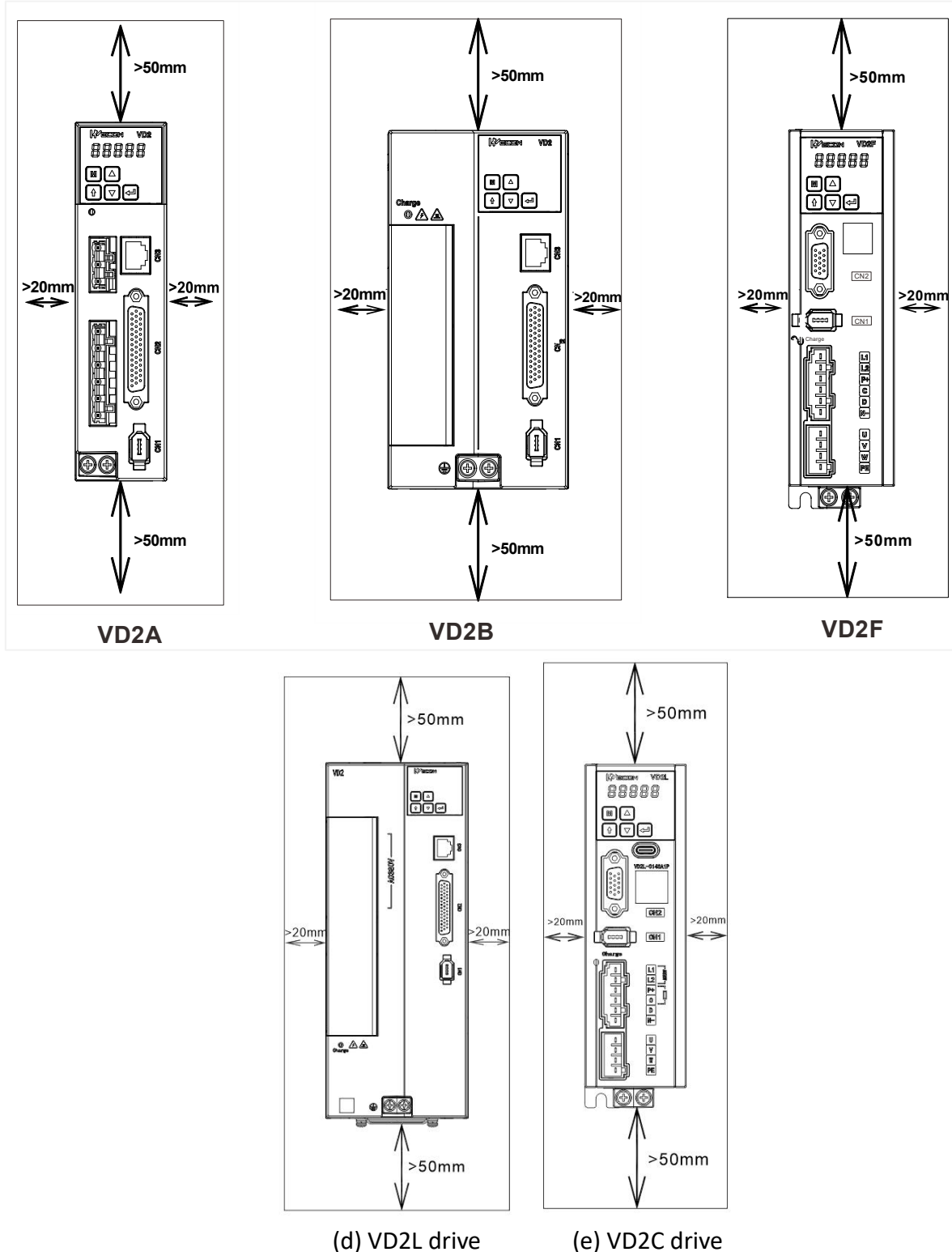

Figure 3-6 Minimum installation size

(2) Parallel installation

When multiple units are installed in parallel, the minimum distance between each other should be 20mm, and the distance between each other should be at least 100mm. Please refer to Figure 3-5 and Figure 3-6 for details. To prevent temperature rise, a cooling fan can be placed on the upper part. If you need a smaller spacing installation, please consult us.

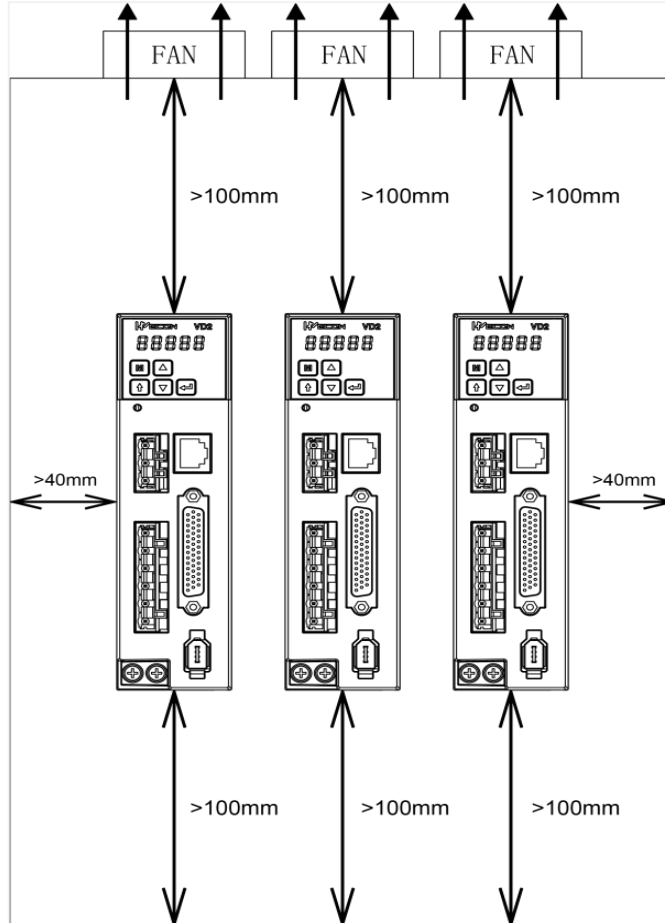

Figure 3-7 Parallel installation dimensions of multiple VD2A drive

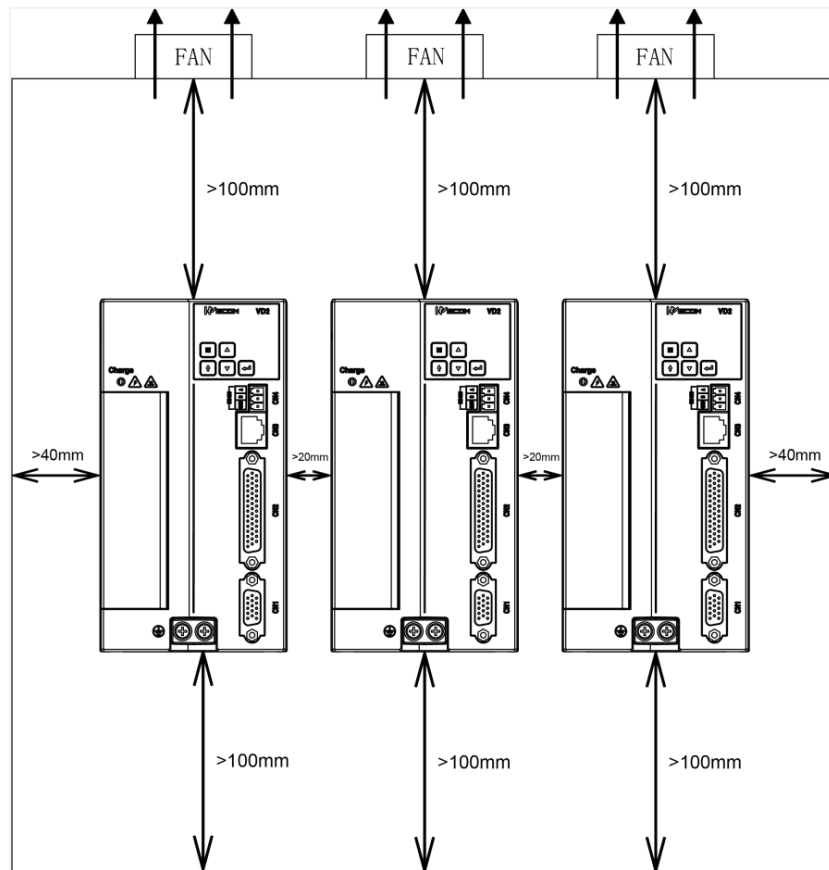

Figure 3-8 Parallel installation dimensions of multiple VD2B drive

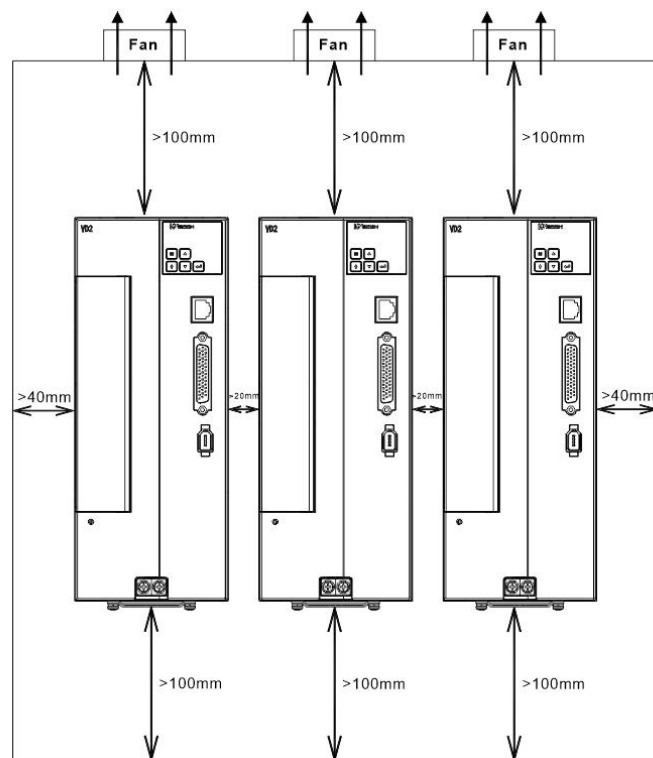

Figure 3-9 Parallel installation dimensions of multiple VD2C drive

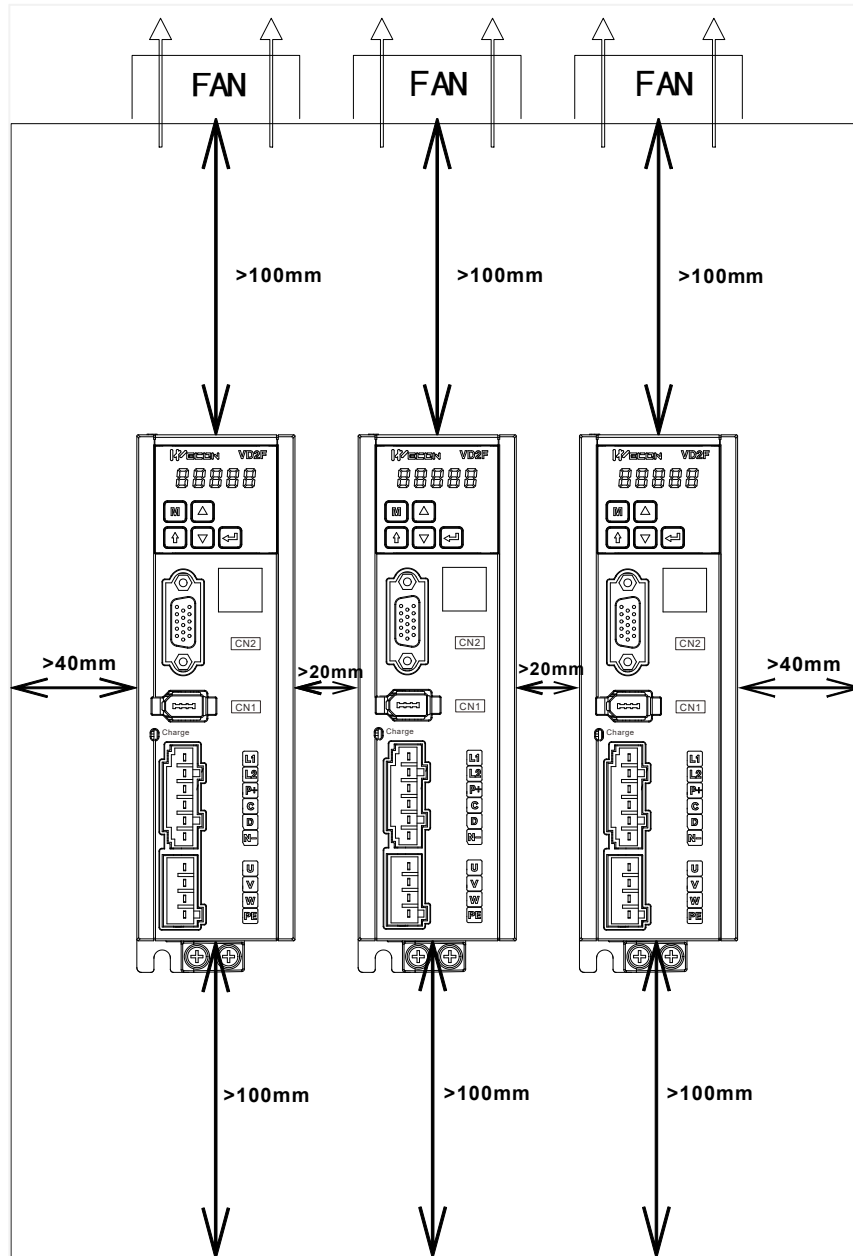

Figure 3-10 Parallel installation dimensions of multiple VD2F drive

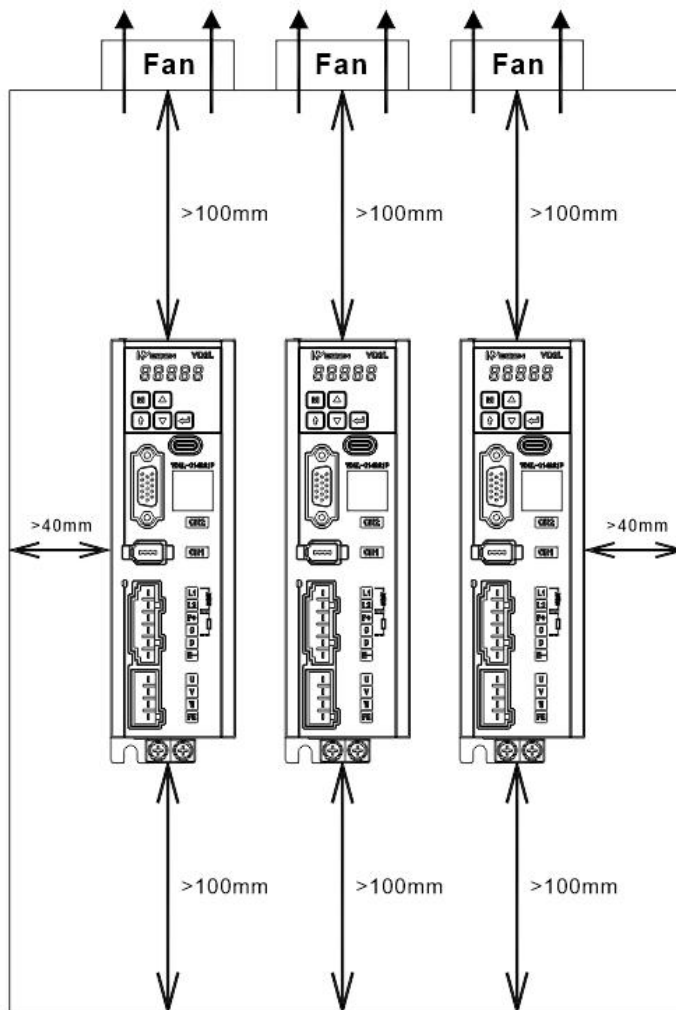

Figure 3-11 Parallel installation dimensions of multiple VD2L drive

(3) Installation direction

When installing the servo drive, please face the front of the servo drive (panel control interface) to the operator so that the servo drive is perpendicular to the wall.

3.2 Installation of servo motor

3.2.1 Installation dimensions (Unit: mm)

(1) Installation dimensions of WD series 40 flange servo motor

Specification	WD series 40 flange motor
Rated torque (N.m)	0.318
LA without brake (mm)	74.8
LA with brake (mm)	108

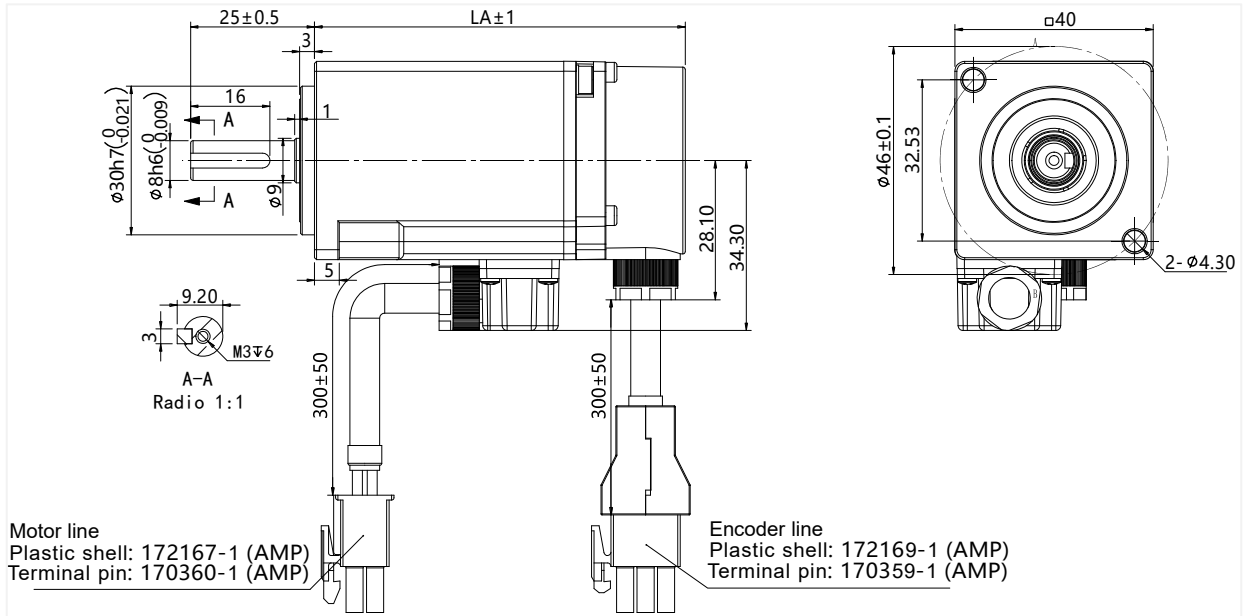

Figure 3-12 Installation dimension of WD series 40 flange servo motor

(2) Installation dimensions of WD series 60 flange servo motor

Specification	WD series 60 flange motor	
Rated torque (N.m)	0.64	1.27
LA without brake (mm)	75	92
LA with brake (mm)	104.5	121.5

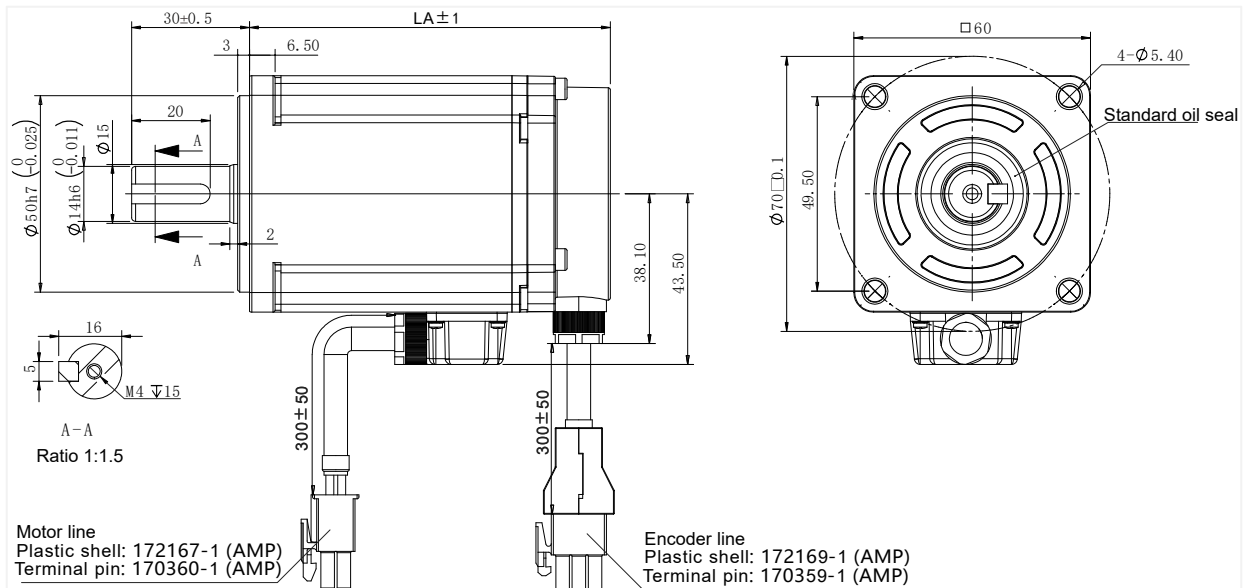

Figure 3-13 Installation dimension of WD series 60 flange servo motor

(3) Installation dimensions of 80 flange servo motor

1) WD series motor

Specification	WD series 80 flange motor
Rated torque (N.m)	2.39
LA without brake (mm)	98.5
LA with brake (mm)	132.5

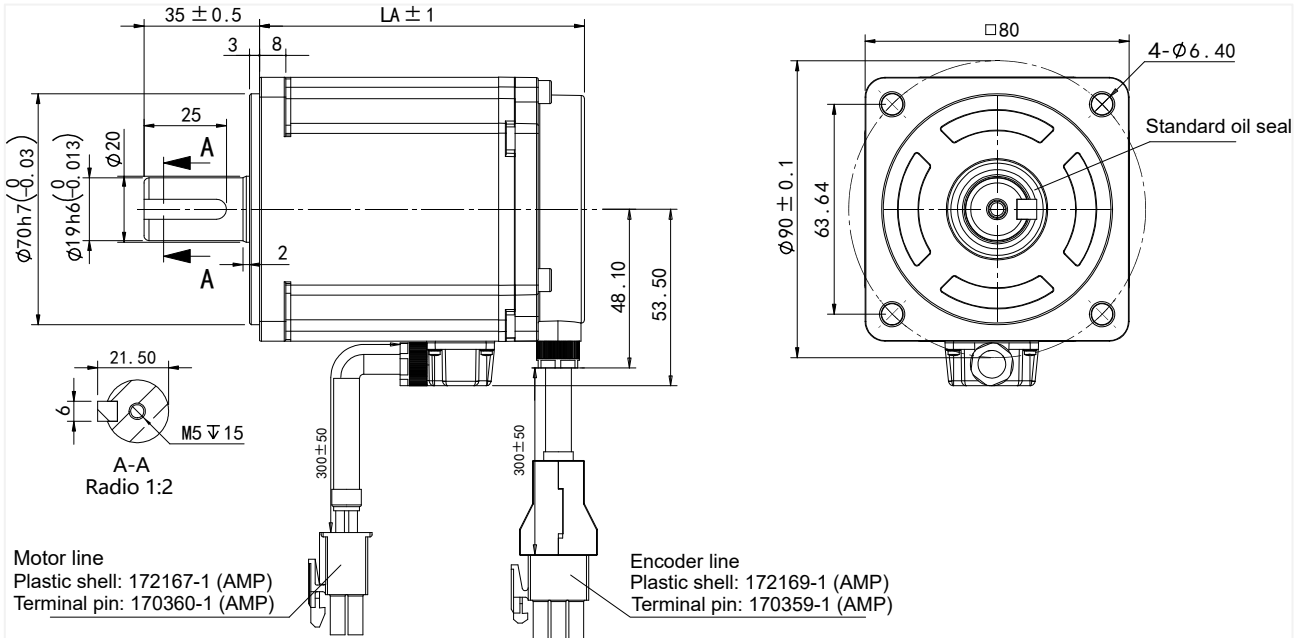

Figure 3-14 Installation dimension of WD series 80 flange motor

2) WE series motor

Specification	WE series 80 flange motor	
Rated torque (N.m)	3.5	4.0
LA without brake (mm)	179	191
LA with brake (mm)	221	233

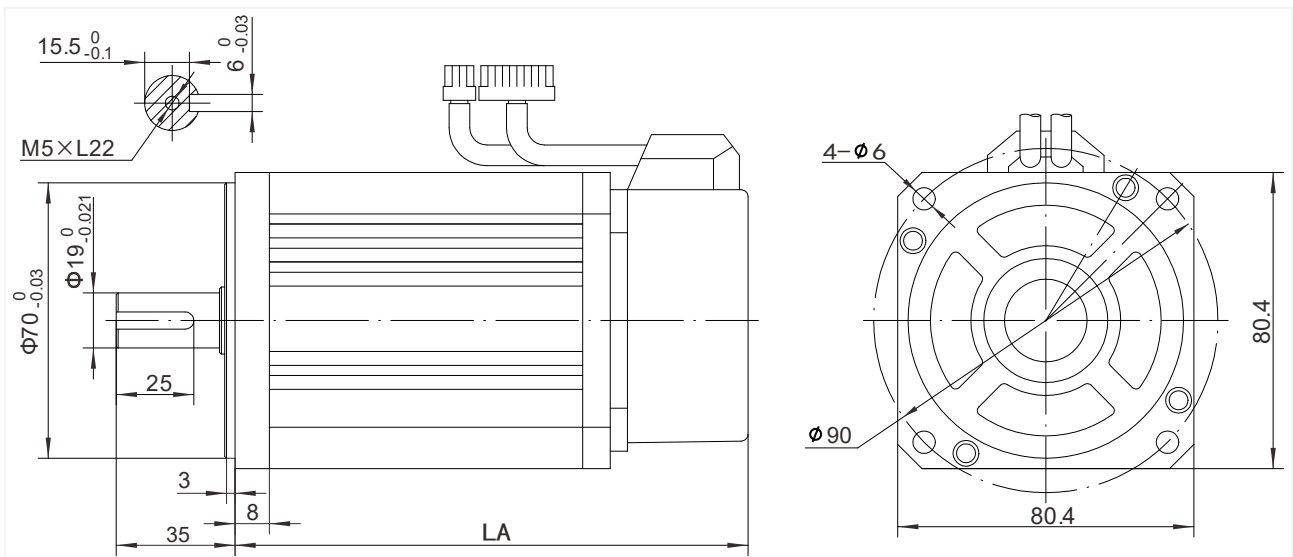

Figure 3-15 Installation dimension of WE series 80 flange motor

(4) Installation dimensions of WE series 110 flange servo motor

Specification	WE series 110 flange motor		
Rated torque (N.m)	4	5	6
LA without brake (mm)	189	204	219
LA with brake (mm)	254	269	284

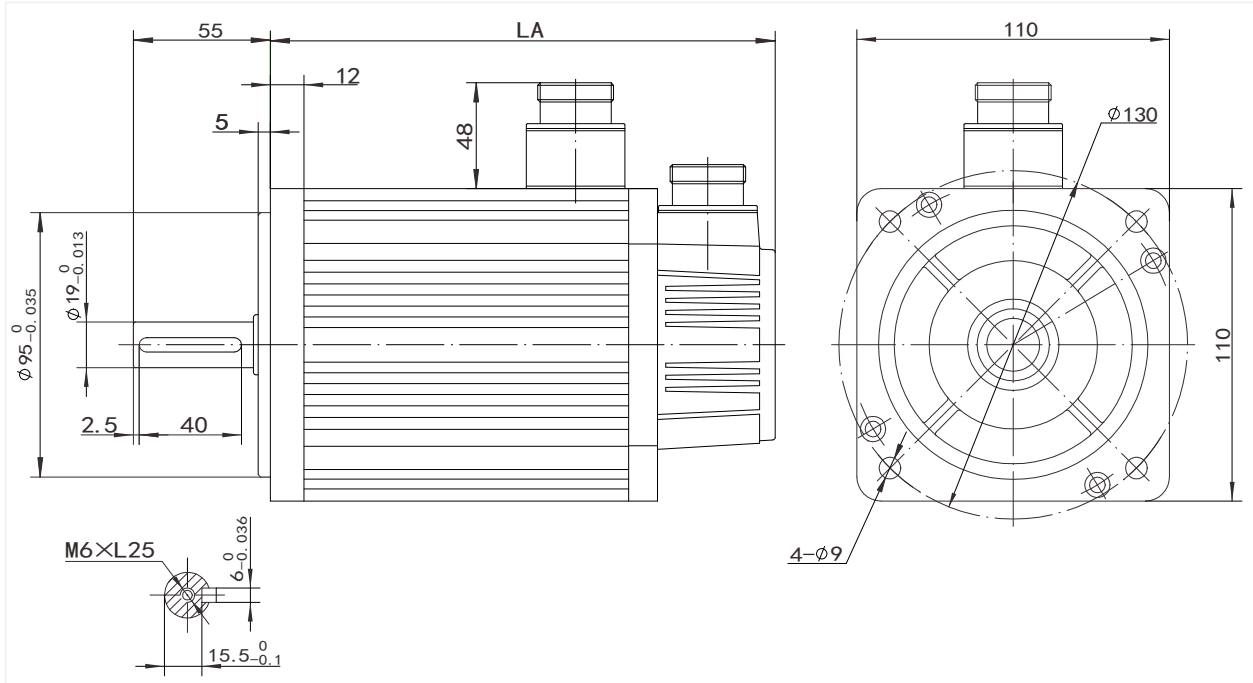

Figure 3-16 Installation dimension of WE series 110 flange servo motor

(5) Installation dimensions of the 130-flange servo motor

Specification	WE series 130 flange motor							
	4	5	6	7.7	10		15	
1500rpm					2000rpm	1500rpm	2500rpm	
LA without brake (mm)	166	171	179	192	213	209	241	231
LA with brake (mm)	226	231	239	252	276	272	304	294

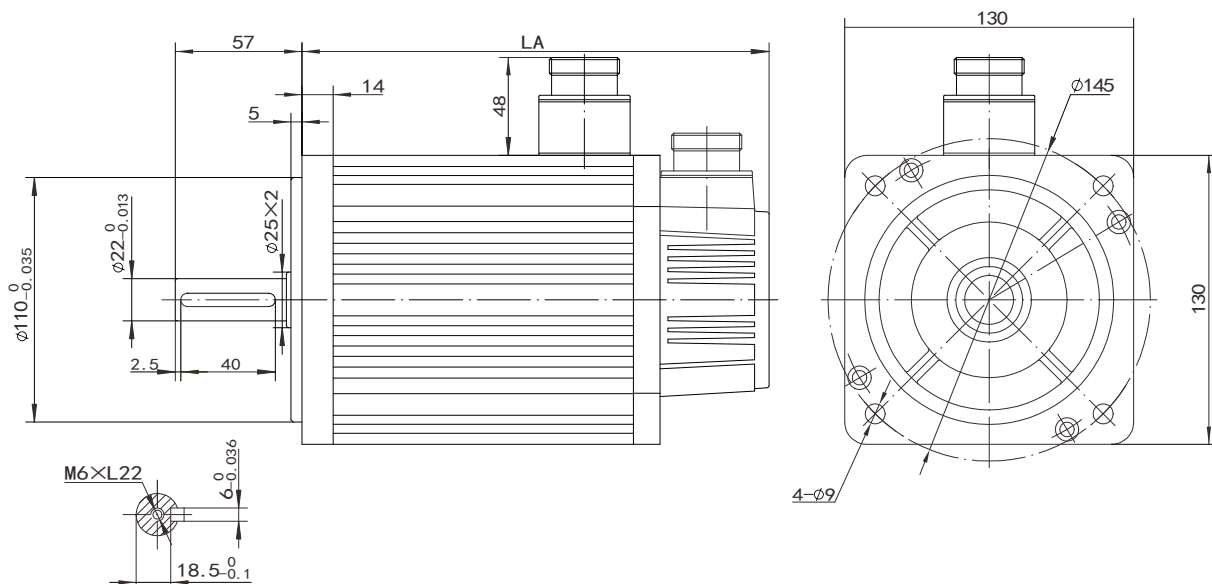

Figure 3-17 Installation dimension of WE series 130 flange servo motor

(6) Installation dimensions of the 180-flange servo motor

Specification	WE series 130 flange motor					
Rated torque (N.m)	17	19	21.5	27	35	48
LA without brake (mm)	226	232	179	192	292	346
LA with brake (mm)	298	304	315	334	364	418

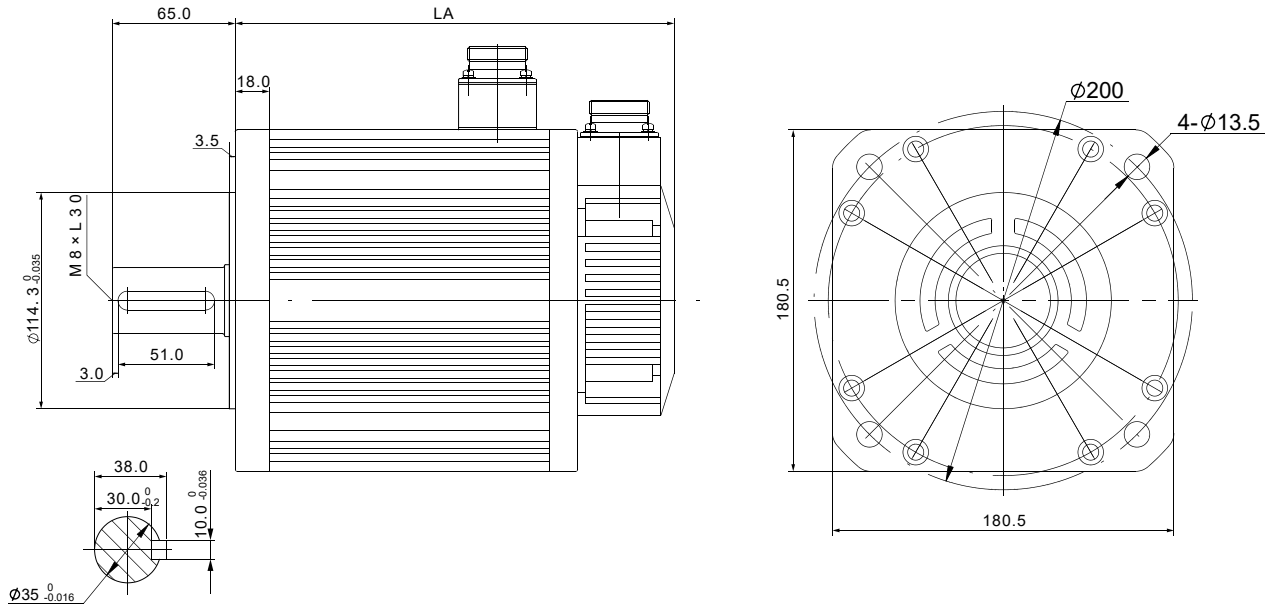

Figure 3-18 Installation dimension of WE series 180 flange servo motor

3.2.2 Installation site

- ① Do not use the motor near corrosive, flammable gas environment, combustible materials such as hydrogen sulfide, chlorine, ammonia, sulfur, chlorinated gas, acid, alkali, salt, etc.
- ② Do not remove the oil seal in places where there is grinding fluid, oil mist, iron powder, cutting, etc.
- ③ Do not use the motor in a closed environment. Closed environment will cause high temperature of the motor and shorten the service life.
- ④ A place far away from heat sources such as stoves.

3.2.3 Installation environment

The installation environment of the servo motor has a direct impact on the normal function of it and its service life. Therefore, the installation environment of the servo motor must meet the following conditions:

Item	Specification
Ambient temperature	-10°C to 40°C (no freezing)
Ambient humidity	-20% to 90%RH (no condensation)
Storage temperature	-20°C to 60°C
Storage humidity	-20% to 90%RH (no condensation)
Protection grade	IP65
Vibration	Less than 0.5G (4.9m/s ²), 10 to 60Hz (non-continuous operation)

3.2.4 Installation precautions

Item	Specification
Rust inhibitor	Before installation, please wipe clean the “rust inhibitor” on the shaft extension end of the servo motor, and then do the relevant anti-rust treatment.
Encoder notice	<ul style="list-style-type: none"> ☞ When installing a pulley on a servo motor shaft with a keyway, use a screw hole at the shaft end. In order to install the pulley, first insert the double-headed nail into the screw hole of the shaft, use a washer on the surface of the coupling end, and gradually lock the pulley into the pulley with a nut; ☞ For the servo motor shaft with keyway, use the screw hole on the shaft end to install; ☞ For shafts without keyway, friction coupling or similar methods are used; ☞ When removing the pulley, use a pulley remover to prevent the bearing from being strongly impacted by the load; ☞ To ensure safety, install a protective cover or similar device in the rotating area, such as a pulley installed on the shaft.
Centering	When linking with the machine, please use the coupling, and keep the axis of the servo motor and the axis of the machine in a straight line.
Installation direction	The servo motor can be installed horizontally or vertically.
Oil and water counter measures	<p>When using in a place with dripping water, please use it after confirming the protection level of the servo motor. When using it in a place where oil drips on the shaft penetration part, do not remove the oil seal of the servo motor.</p> <p>The use conditions of the servo motor with oil seal:</p> <ul style="list-style-type: none"> ☞ When using, please make sure the oil level is lower than the lip of the oil seal; ☞ The oil seal can be used in a state with a good degree of splashing of oil foam; ☞ When the servo motor is installed vertically upwards, please be careful not to accumulate oil on the oil seal lip.
Stress condition of the cable	Do not "bend" the wire or apply "tension" to it, especially the signal wire whose core diameter is 0.2mm or 0.3mm. During the wiring process, please do not make it too tight.
Processing of the connector part	<p>Regarding the connector part, please note the following:</p> <ul style="list-style-type: none"> ☞ When connecting the connector, please make sure that there is no foreign matter such as garbage or metal pieces in the connector; ☞ When connecting the connector to the servo motor, be sure to connect it from the side of the main circuit cable of the servo motor first, and the grounding of the main line cable must be reliably connected. If you connect one side of the encoder cable first, the encoder may malfunction due to the potential difference between PEs; ☞ When connecting, please make sure that the pin arrangement is correct; ☞ The connector is made of resin, please do not apply impact to avoid damage to the connector; ☞ Do not apply stress to the connector part while carrying the cable while the cable is connected. If stress is applied to the connector part, the connector may be damaged.

4. Wiring

4.1 Main circuit wiring

4.1.1 Main circuit terminals

(1) VD2A servo drive main circuit terminal distribution

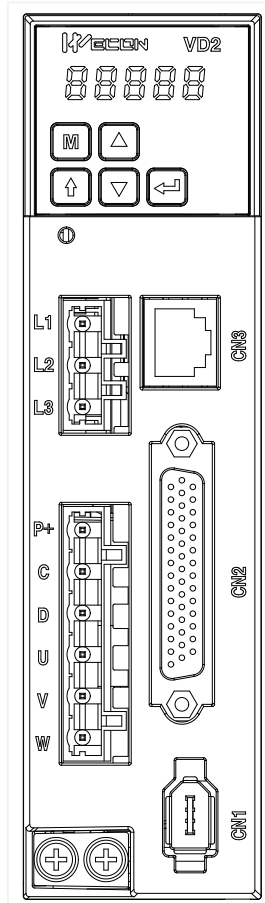

Figure 4-1 VD2A servo drive main circuit terminal distribution

Terminal number	Terminal name	Terminal function
L1	Power input terminal	Single-phase 220V AC input is connected to L1 and L3.
L2		
L3		
P+	Braking resistor terminal	Use internal braking resistor: short-circuit C and D. Use external braking resistor: Please disconnect the short wire between C and D, and then connect the external braking resistor between P+ and C;
C		
D		
U	Motor power line terminal	Connect with the U, V and W of motor to power the motor.
V		
W		
Ground terminal	Ground terminal	Grounding treatment of servo drive.

Table 4-1 The name and function of VD2A servo drive main circuit terminal

(2) VD2B servo drive (220V) main circuit terminal distribution

Figure 4-2 VD2B servo drive (220V) main circuit terminal distribution

Terminal number	Terminal name	Terminal function
L1	Power input terminal	Three-phase 220V AC input is connected to L1, L2, L3; Single-phase 220V AC input is connected to L1 and L3.
L2		
L3		
L1C	Control power input terminal	Single-phase 220V AC input is connected to L1C and L2C.
L2C		
P+	Braking resistor terminal	Use internal braking resistor: short-circuit C and D. Use external braking resistor: Please disconnect the short wire between C and D, and then connect the external braking resistor between P+ and C.
C		
D		
U	Motor power line terminal	Connect with the U, V and W of motor to power the motor.
V		
W		
Ground terminal	Ground terminal	Grounding treatment of servo drive.

Table 4-2 The name and function of VD2B servo drive (220V) main circuit terminal

(3) VD2B servo drive (380V) main circuit terminal distribution

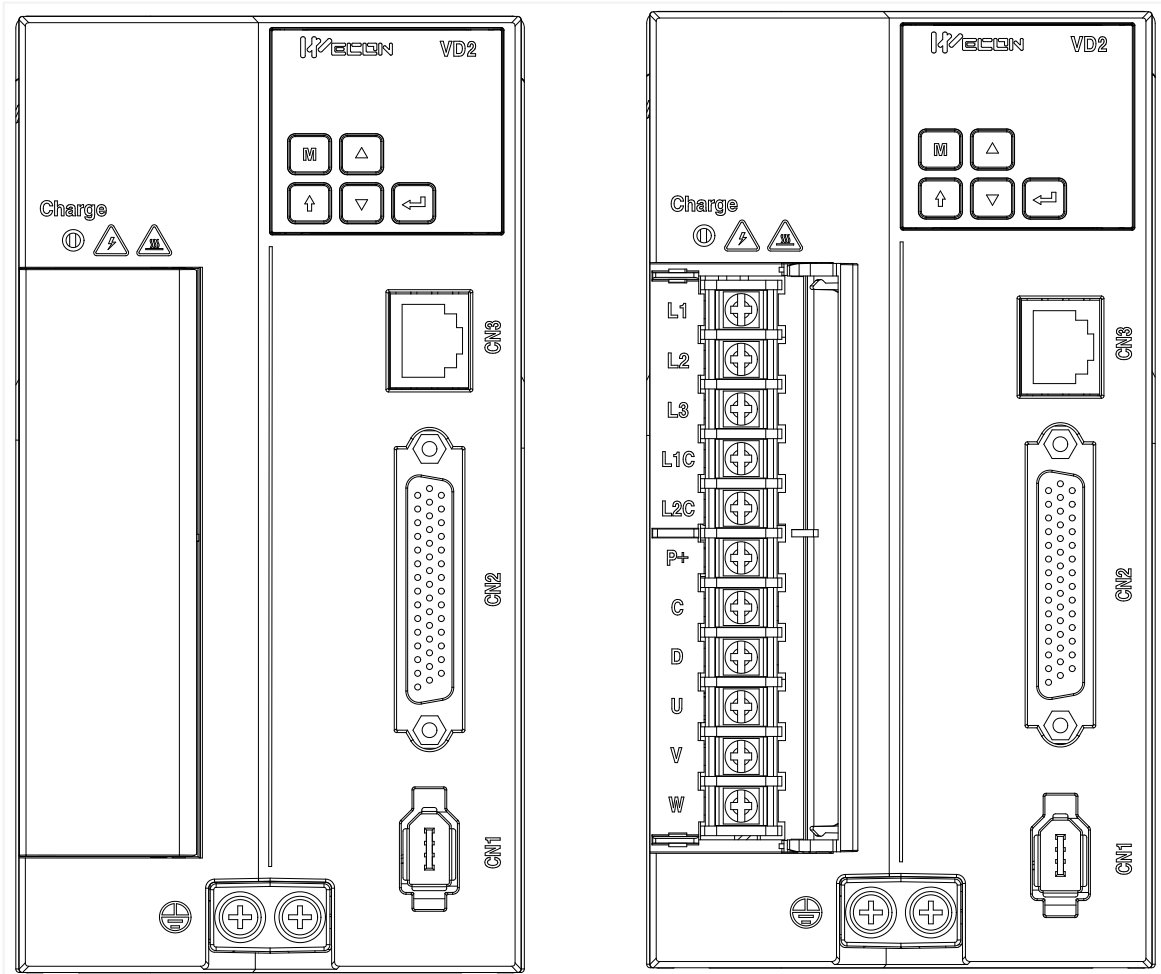
Figure 4-3 VD2B servo drive (380V) main circuit terminal distribution

Terminal number	Terminal name	Terminal function
L1	Power input terminal	Three-phase 380V AC input is connected to L1, L2, L3;
L2		
L3		
L1C	Control power input terminal	Single-phase 380V AC input is connected to L1C and L2C.
L2C		
P+	Braking resistor terminal	Use internal braking resistor: short-circuit C and D. Use external braking resistor: Please disconnect the short wire between C and D, and then connect the external braking resistor between P+ and C.
C		
D		
U	Motor power line terminal	Connect with the U, V and W of motor to power the motor.
V		
W		
Ground terminal	Ground terminal	Grounding treatment of servo drive.

Table 4-3 The name and function of VD2B servo drive (380V) main circuit terminal

(4) VD2C servo drive (380V) main circuit terminal distribution

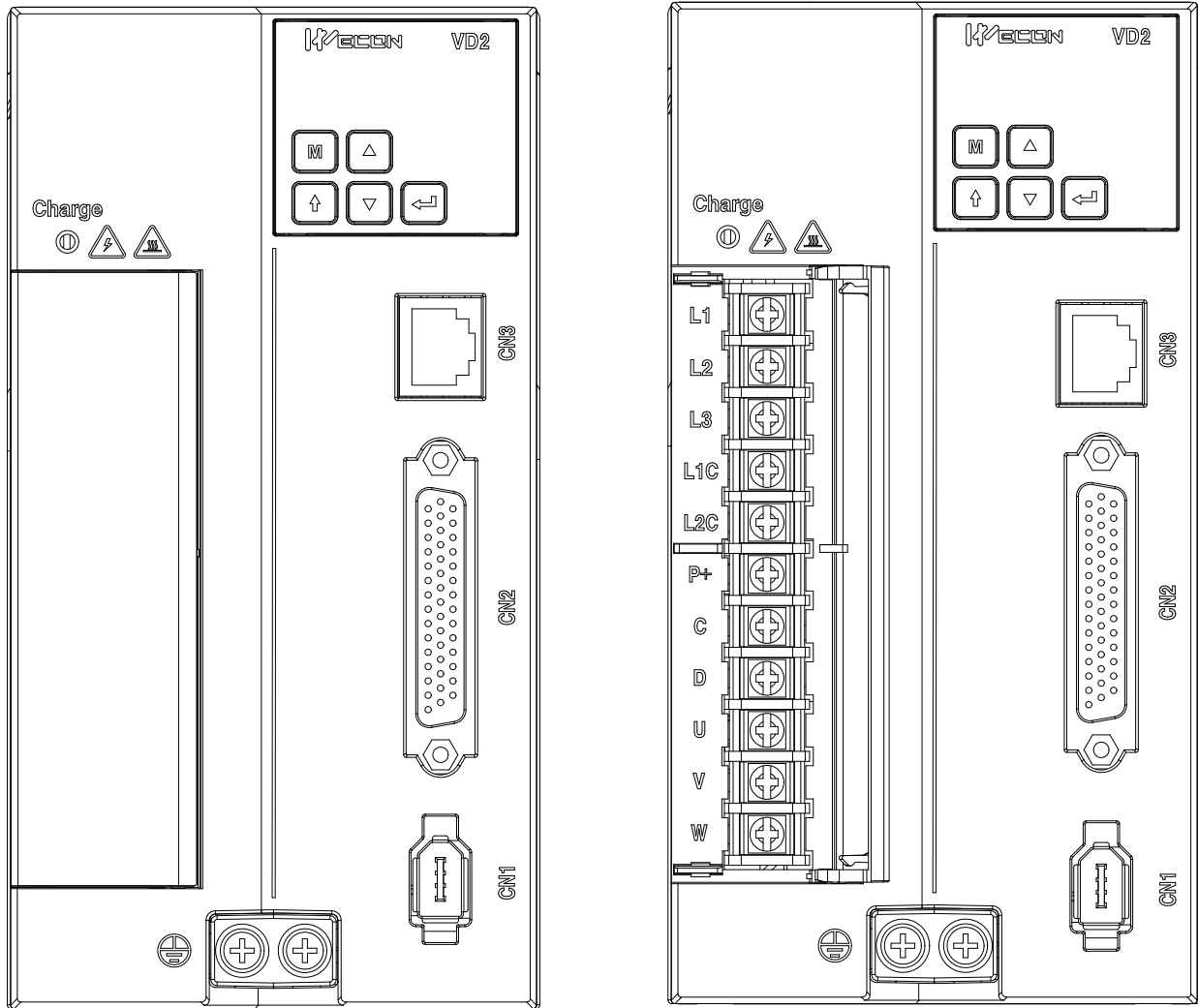
Figure 4-4 VD2C servo drive (380V) main circuit terminal distribution

Terminal number	Terminal name	Terminal function
L1	Power input terminal	Three-phase 380V AC input is connected to L1, L2, L3;
L2		
L3		
L1C	Control power input terminal	Single-phase 380V AC input is connected to L1C and L2C.
L2C		
P+	Braking resistor terminal	Use internal braking resistor: short-circuit C and D. Use external braking resistor: Please disconnect the short wire between C and D, and then connect the external braking resistor between P+ and C.
C		
D		
U	Motor power line terminal	Connect with the U, V and W of motor to power the motor.
V		

W		
Ground terminal	Ground terminal	Grounding treatment of servo drive.

Table 4-4 The name and function of VD2C servo drive (380V) main circuit terminal

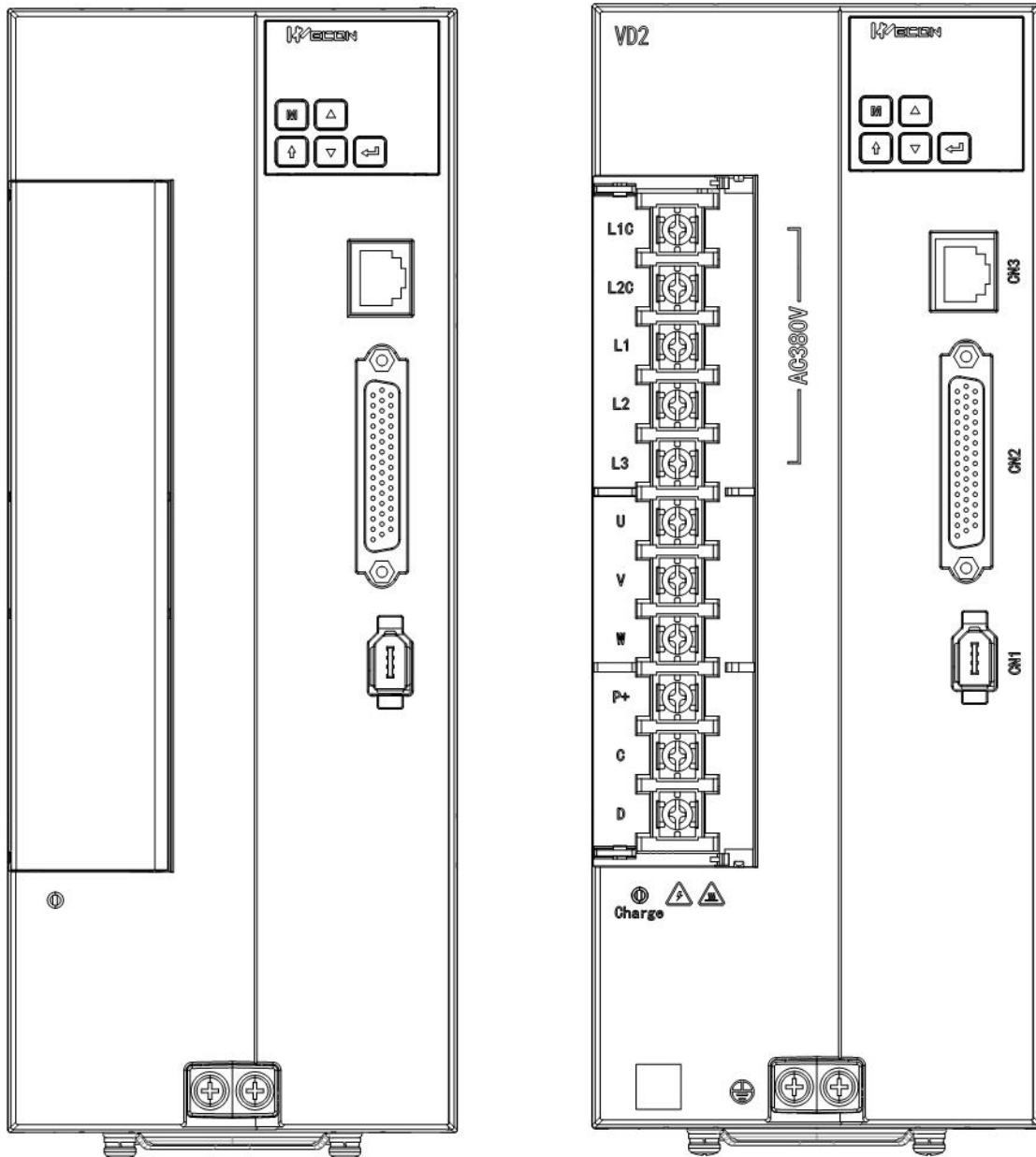
(5) VD2F servo drive main circuit terminal distribution

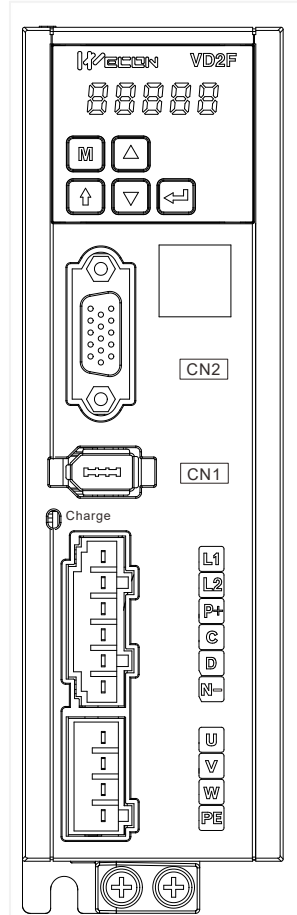

Figure 4-5 VD2F servo drive main circuit terminal distribution

Terminal number	Terminal name	Terminal function
L1	Power input terminal	Connect single-phase 220V input power
L2		
P+	Braking resistor terminal	Use internal braking resistor: short-circuit C and D.
C		Use external braking resistor: Please disconnect the short wire between C and D, and then connect the external braking resistor between P+ and C.
D		
P+	Common DC bus terminal	DC bus terminal of servo drive
N		
U	Motor power line terminal	Connect with the U, V and W of the motor to power the motor.
V		
W		
PE	Ground terminal	Grounding treatment of the servo drive.

Table 4-5 The name and function of VD2F servo drive main circuit terminal

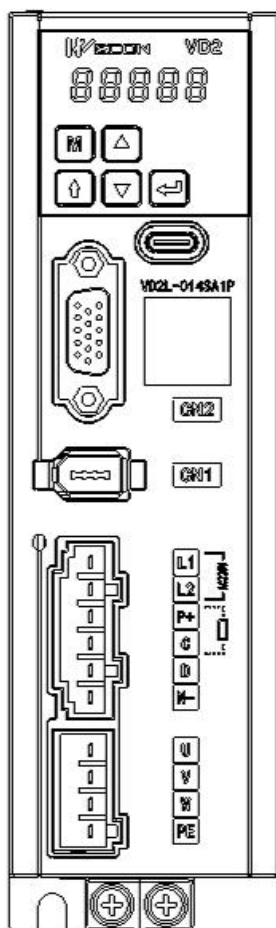

Figure 4-6 VD2L servo drive main circuit terminal distribution

Terminal number	Terminal name	Terminal function
L1	Power input terminal	Connect single-phase 220V input power
L2		
P+	Braking resistor terminal	Use internal braking resistor: short-circuit C and D.
C		Use external braking resistor: Please disconnect the short wire between C and D, and then connect the external braking resistor between P+ and C.
D		
P+	Common DC bus terminal	DC bus terminal of servo drive
N		
U	Motor power line terminal	Connect with the U, V and W of the motor to power the motor.
V		
W		
PE	Ground terminal	Grounding treatment of the servo drive.

Table 4-6 The name and function of VD2L servo drive (380V) main circuit terminal

4.1.2 Power wiring

(1) Use single-phase 220V power supply model: VD2-010SA1G and VD2-014SA1G

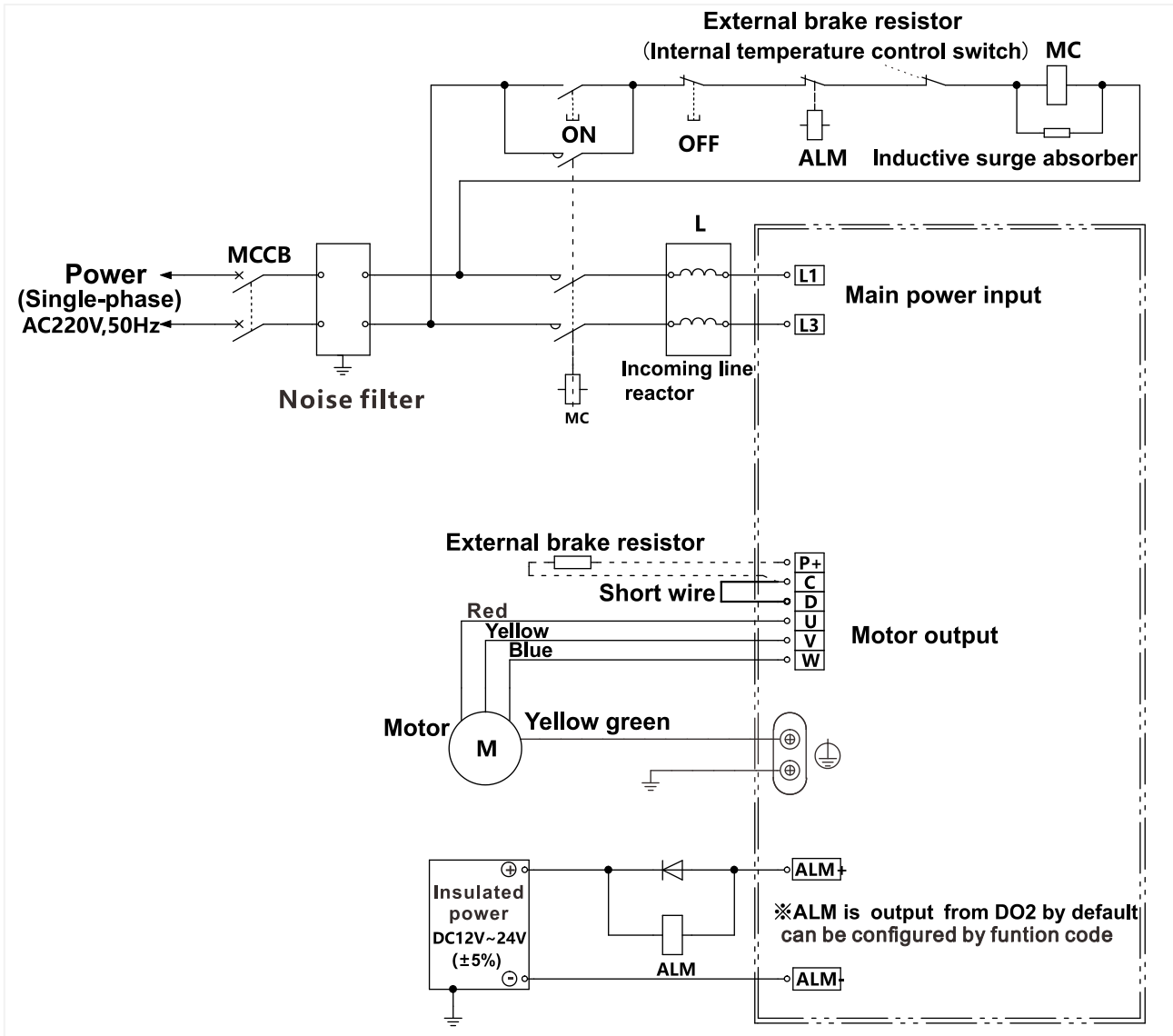

Figure 4-7 VD2A drive single-phase 220V main circuit wiring

(2) Use single-phase 220V power supply model: VD2-016SA1G, VD2-019SA1G, VD2-016SA1H, VD2-019SA1H

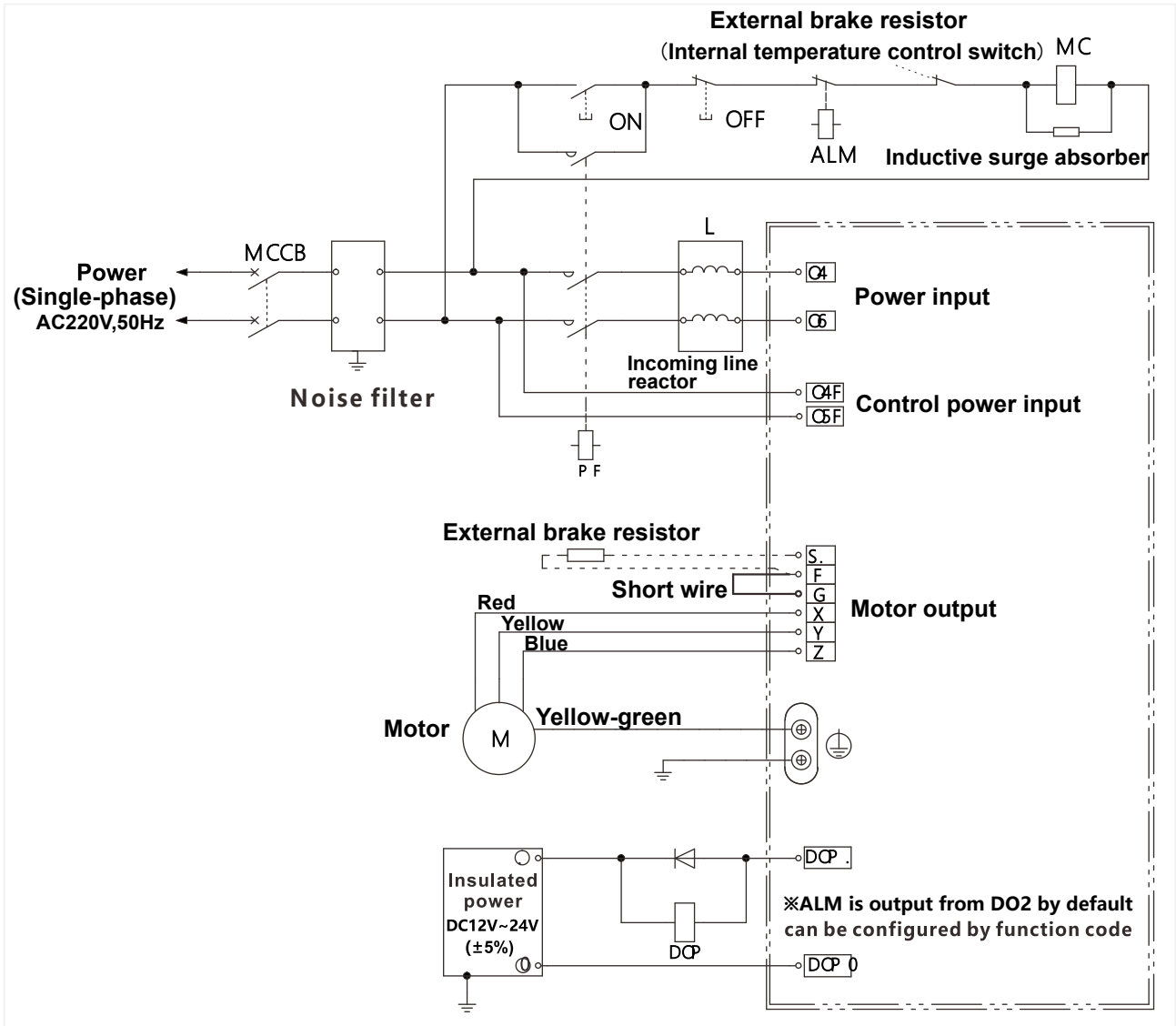

Figure 4-8 VD2B drive single-phase 220V main circuit wiring

(3) Use three-phase 220V power supply model: VD2-021SA1G, VD2-025SA1G, VD2-030SA1G, VD2-021SA1H

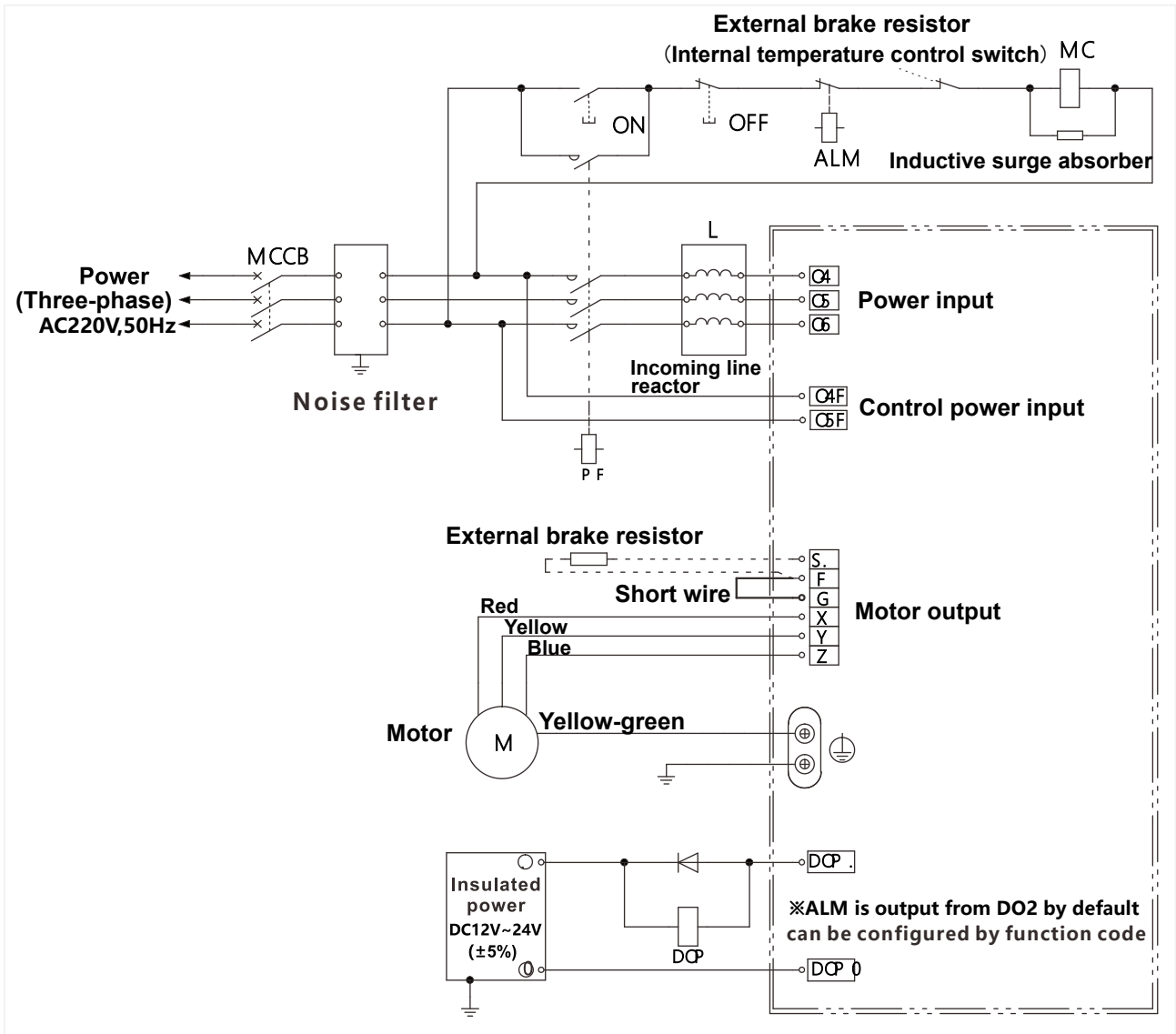

Figure 4-9 VD2B drive three-phase 220V main circuit wiring

(4) Use single-phase 220V power supply model: VD2F-003SA1P、VD2F-010SA1P、VD2F-014SA1P

Figure 4-10 VD2F/VD2L drive single-phase 220V main circuit wiring

(5) Use three-phase 380V power supply model: VD2-021TA1G

Figure 4-11 VD2B/VD2C drive three-phase 380V main circuit wiring

4.1.3 Precautions for main circuit wiring

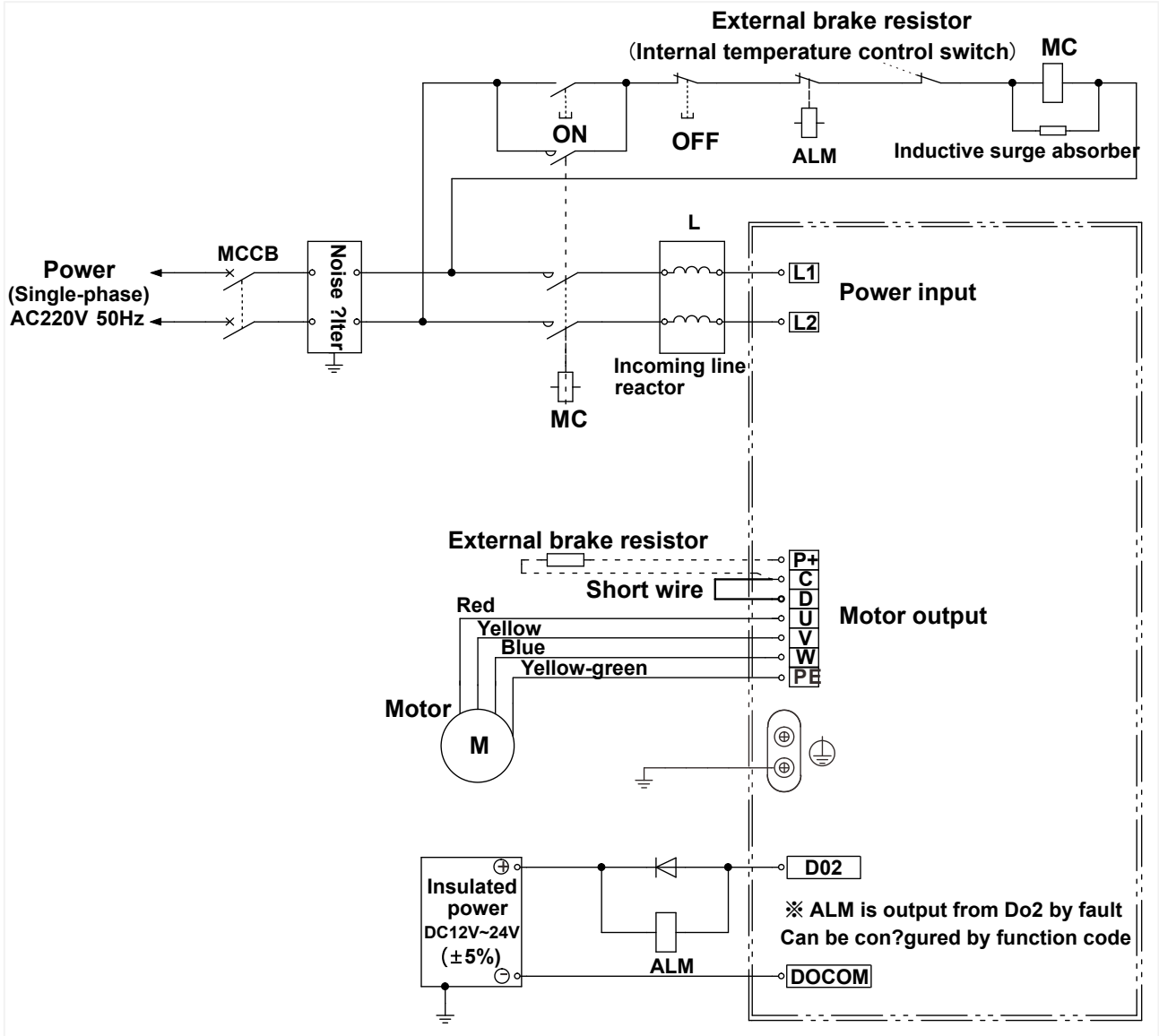
- ① Do not connect the input power cord to the output terminals U, V, W, otherwise the servo drive will be damaged. When using the built-in braking resistor, C and D must be connected (factory default connection).
- ② When the cables are bundled and used in pipes, etc., due to the deterioration of heat dissipation conditions, please consider the allowable current reduction rate.
- ③ When the temperature in the cabinet is higher than the cable temperature limit, please choose a cable with a larger cable temperature limit, and it is recommended that the cable wire use Teflon wire. Please pay attention to the warmth of the cable in the low temperature environment. Generally, the surface of the cable is easy to harden and break under the low temperature environment.
- ④ The bending radius of the cable should be more than 10 times the outer diameter of the cable itself to prevent the core of the cable from breaking due to long-term bending.

4.2 Power line connection of servo drive and servo motor

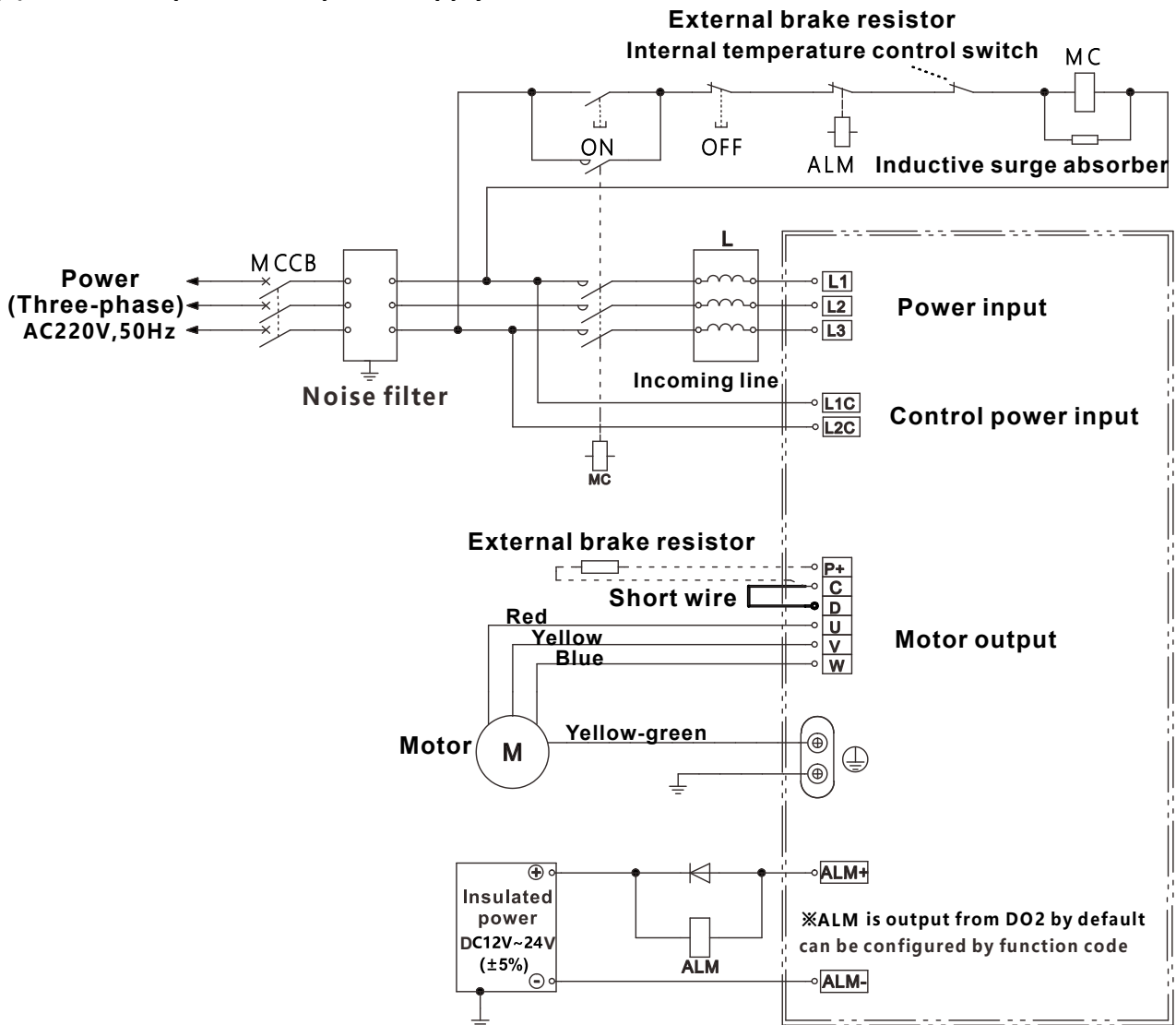
4.2.1 Power line

Wecon VD2 series servo drive has 3 kinds of interface power cables: rectangular plug, aviation plug and in-line type.

Connector exterior	Terminal pin distribution	Pin description	Motor flange		
		Rectangular plug		40 60 80	
		Pin number	Signal name		Color
		1	U		Red
		2	V		White
		3	W		Black
4	PE	Yellow-green			
		Aviation plug		110 130	
		Pin number	Signal name		Color
		2	U		Black
		4	V		Yellow-green
		3	W		Black
1	PE	Black			
		In-line type plug		60 80	
		Pin number	Signal name		Color
		3	U		Red
		1	V		White
		2	W		Black
4	PE	Yellow-green			

Table 4-7 Power cable servo motor side connector

Note: The color of the lines is subject to the actual product. The lines described in this manual are all lines of Wecon.

4.2.2 Brake device cable

Connector exterior	terminal pin distribution	Motor flange								
WD series 	<table border="1"> <thead> <tr> <th>Pin number</th> <th>Signal name</th> </tr> </thead> <tbody> <tr> <td>1</td> <td>BR+</td> </tr> <tr> <td>2</td> <td>BR-</td> </tr> </tbody> </table>	Pin number	Signal name	1	BR+	2	BR-	40 60 80		
Pin number	Signal name									
1	BR+									
2	BR-									
WE series 	<table border="1"> <thead> <tr> <th>Pin number</th> <th>Signal name</th> </tr> </thead> <tbody> <tr> <td>1</td> <td>DC 24V</td> </tr> <tr> <td>2</td> <td>GND</td> </tr> <tr> <td>3</td> <td>-</td> </tr> </tbody> </table>	Pin number	Signal name	1	DC 24V	2	GND	3	-	80 110 130
Pin number	Signal name									
1	DC 24V									
2	GND									
3	-									

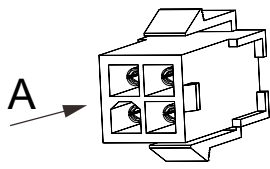
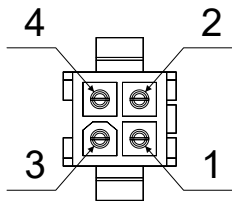
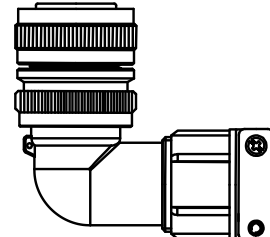
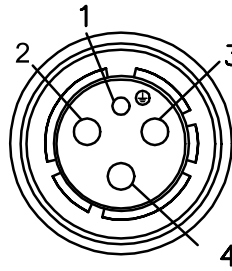
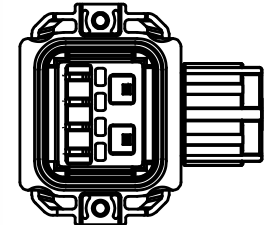
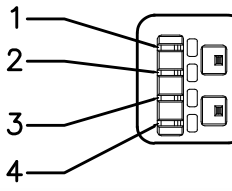
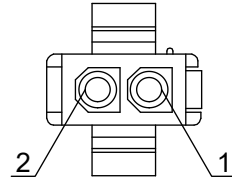
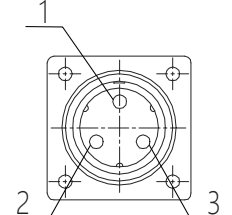
4.3 Encoder cable connection of servo drive and servo motor

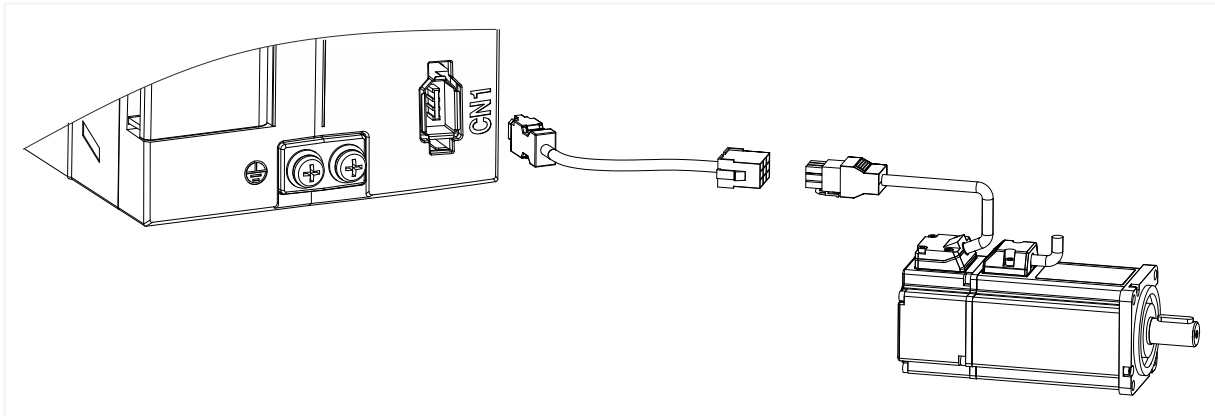

Figure 4-12 Encoder connection line wiring

Connector exterior	Terminal pin distribution	Pin description														
		<table border="1"> <thead> <tr> <th>Pin number</th> <th>Signal name</th> </tr> </thead> <tbody> <tr> <td>1</td> <td>5V</td> </tr> <tr> <td>2</td> <td>GND</td> </tr> <tr> <td>3</td> <td>-</td> </tr> <tr> <td>4</td> <td>-</td> </tr> <tr> <td>5</td> <td>SD+</td> </tr> <tr> <td>6</td> <td>SD-</td> </tr> </tbody> </table>	Pin number	Signal name	1	5V	2	GND	3	-	4	-	5	SD+	6	SD-
Pin number	Signal name															
1	5V															
2	GND															
3	-															
4	-															
5	SD+															
6	SD-															

Table 4-8 Encoder cable servo drive side connector

Connector exterior and terminal pin distribution		Motor flange															
<p>Connector of endoder pinout</p> <p>Connect servo drive CN1</p>	<p>Encoder pinout</p>	40 60 80															
<p>View from here</p>	<p>View from here</p>																
<table border="1" style="margin-left: auto; margin-right: auto;"> <thead> <tr> <th>Pin number</th> <th>Signal name</th> </tr> </thead> <tbody> <tr> <td>7</td> <td>5V</td> </tr> <tr> <td>8</td> <td>GND</td> </tr> <tr> <td>4</td> <td>SD+</td> </tr> <tr> <td>5</td> <td>SD-</td> </tr> <tr> <td>3</td> <td>Shield</td> </tr> <tr> <td>1</td> <td>Battery+</td> </tr> <tr> <td>2</td> <td>Battery-</td> </tr> </tbody> </table>			Pin number	Signal name	7	5V	8	GND	4	SD+	5	SD-	3	Shield	1	Battery+	2
Pin number	Signal name																
7	5V																
8	GND																
4	SD+																
5	SD-																
3	Shield																
1	Battery+																
2	Battery-																

Table 4-9 Absolute value encoder line connector (Rectangular plug)

Drive side J1394		Description	Motor side	
Pin number	Signal name		Rectangular plug pin number	Cable color
1	5V	Encoder +5v power	7	Blue
2	GND	Encoder power ground	8	Orange
5	SD+	Serial communication signal +	4	Green
6	SD-	Serial communication signal -	5	Brown
Shell	Shield	Shield	3	-
-	-	Battery+	1*	Pink
-	-	Battery-	2*	Pink-Black

Table 4-10 Connection of encoder line pin

The pin with "*" indicates the signal line of encoder battery. If the multi-turn battery memory function is not used, you don't need to connect the signal lines. It is only used as single turn encoder line at this time.

Note: The color of cable is subject to the actual product. The lines described in this manual are all from Wecon!

Connector shape and terminal pin distribution		Motor flange																
<p>Connector of encoder pinout</p> <p>Connect servo drive CN1</p>	<p>Encoder connected to a socket</p>	110 130																
	<table border="1"> <thead> <tr> <th>Pin number</th> <th>Signal name</th> </tr> </thead> <tbody> <tr> <td>7</td> <td>5V</td> </tr> <tr> <td>5</td> <td>GND</td> </tr> <tr> <td>6</td> <td>SD+</td> </tr> <tr> <td>4</td> <td>SD-</td> </tr> <tr> <td>1</td> <td>Shield</td> </tr> <tr> <td>3</td> <td>Battery+</td> </tr> <tr> <td>2</td> <td>Battery-</td> </tr> </tbody> </table>	Pin number	Signal name	7	5V	5	GND	6	SD+	4	SD-	1	Shield	3	Battery+	2	Battery-	
Pin number	Signal name																	
7	5V																	
5	GND																	
6	SD+																	
4	SD-																	
1	Shield																	
3	Battery+																	
2	Battery-																	

Table 4-11 Absolute value encoder line connector (Aviation connector)

Drive side J1394		Description	Motor side	
Pin number	Signal name		Aviation plug pin number	Cable color
1	5V	Encoder +5v power	7	Blue
2	GND	Encoder power ground	5	Orange
5	SD+	Serial communication signal +	6	Green
6	SD-	Serial communication signal -	4	Brown
Shell	Shield	Shield	1	-
-	-	Battery+	3*	Pink
-	-	Battery-	2*	Pink-Black

Table 4-12 Absolute encoder cable connector (Aviation socket)

The pin with “*” indicates the signal line of encoder battery. If the multi-turn battery memory function is not used, you don’t need to connect the signal lines. It is only used as single turn encoder line at this time.

Note: The color of the cable is subject to the actual product. The cables described in this manual are all cables of Wecon!

Connector shape and terminal pin distribution		Motor flange															
		60 80															
<table border="1"> <thead> <tr> <th>Pin number</th> <th>Signal name</th> </tr> </thead> <tbody> <tr> <td>7</td> <td>5V</td> </tr> <tr> <td>5</td> <td>GND</td> </tr> <tr> <td>6</td> <td>SD+</td> </tr> <tr> <td>4</td> <td>SD-</td> </tr> <tr> <td>1</td> <td>Shield</td> </tr> <tr> <td>3</td> <td>Battery+</td> </tr> <tr> <td>2</td> <td>Battery-</td> </tr> </tbody> </table>			Pin number	Signal name	7	5V	5	GND	6	SD+	4	SD-	1	Shield	3	Battery+	2
Pin number	Signal name																
7	5V																
5	GND																
6	SD+																
4	SD-																
1	Shield																
3	Battery+																
2	Battery-																

Table 4-13 Absolute encoder cable connector (in-line type)

Drive side J1394		Description	Motor side	
Pin number	Signal name		In-line plug pin number	Cable color
1	5V	Encoder +5v power	7	Blue
2	GND	Encoder power ground	5	Orange
5	SD+	Serial communication signal +	6	Green
6	SD-	Serial communication signal -	4	Brown
Shell	Shield	Shield	1	-
-	-	Battery+	3*	Brown
-	-	Battery-	2*	Black

Table 4-14 Connection of encoder line pin

The pin with “*” indicates the signal line of encoder battery. If the multi-turn battery memory function is not used, you don’t need to connect the signal lines. It is only used as single turn encoder line at this time.

Note:

The color of the cable is subject to the actual product. The cables described in this manual are all cables of Wecon!

Connector shape and terminal pin distribution		Motor flange															
		60 80															
<table border="1" style="margin-left: auto; margin-right: auto;"> <thead> <tr> <th>Pin number</th> <th>Signal name</th> </tr> </thead> <tbody> <tr> <td>1</td> <td>5V</td> </tr> <tr> <td>2</td> <td>GND</td> </tr> <tr> <td>3</td> <td>SD+</td> </tr> <tr> <td>4</td> <td>SD-</td> </tr> <tr> <td>5</td> <td>Shield</td> </tr> <tr> <td>6</td> <td>Battery+</td> </tr> <tr> <td>7</td> <td>Battery-</td> </tr> </tbody> </table>			Pin number	Signal name	1	5V	2	GND	3	SD+	4	SD-	5	Shield	6	Battery+	7
Pin number	Signal name																
1	5V																
2	GND																
3	SD+																
4	SD-																
5	Shield																
6	Battery+																
7	Battery-																

Table 4-15 Absolute encoder cable connector (in-line type)

Drive side J1396		Description	Motor side	
Pin number	Signal name		In-line plug pin number	Cable color
1	5V	Encoder +5V power	1	White
2	GND	Encoder power ground	2	Brown
5	SD+	Serial communication signal +	3	Green
6	SD-	Serial communication signal -	4	Yellow
Shell	Shield	Shield	5	-
-	-	Battery+	6*	Pink
-	-	Battery-	7*	Black

Table 4-16 Connection of encoder line pin

The pin with “*” indicates the signal line of encoder battery. If the multi-turn battery memory function is not used, you don’t need to connect the signal lines. It is only used as single turn encoder line at this time.

Note:

The color of the cable is subject to the actual product. The cables described in this manual are all cables of Wecon!

4.4 Servo drive control input and output wiring

4.4.1 CN2 pin distribution

(1) VD2A, VD2B and VD2C servo drive control input and output pin distribution (CN2 interface)

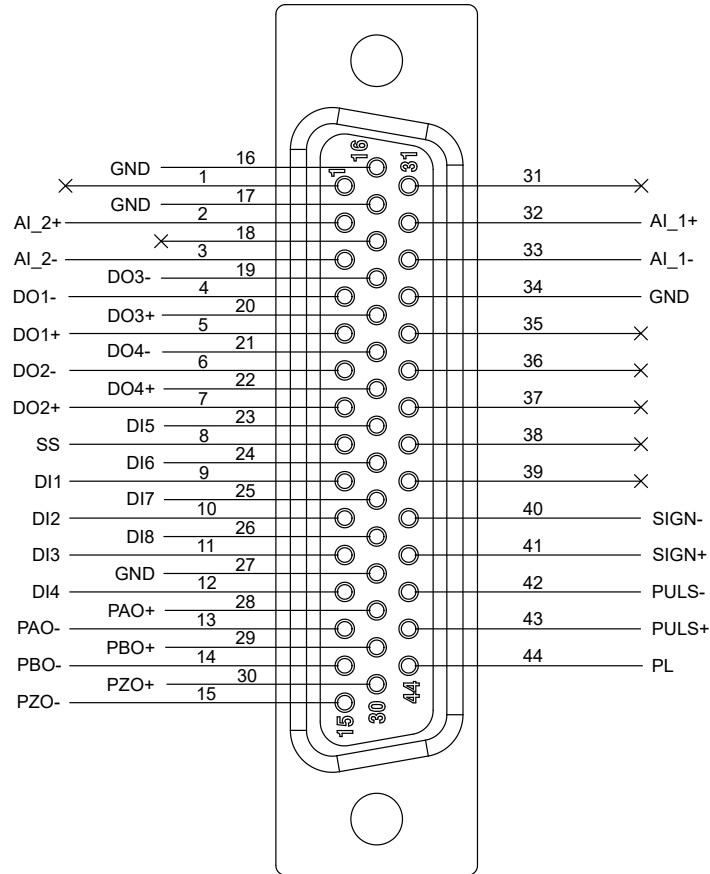

Figure 4-13 VD2A, VD2B and VD2C servo drive control input and output pin distribution

Pin number	Signal name	Pin number	Signal name	Pin number	Signal name
1	-	16	GND	31	-
2	AI_2+	17	GND	32	AI_1+
3	AI_2-	18	-	33	AI_1-
4	DO1-	19	DO3-	34	GND
5	DO1+	20	DO3+	35	-
6	DO2-	21	DO4-	36	-
7	DO2+	22	DO4+	37	-
8	SS	23	DI5	38	-
9	DI1	24	DI6	39	-
10	DI2	25	DI7	40	SIGN-
11	DI3	26	DI8	41	SIGN+
12	DI4	27	GND	42	PULS-
13	PAO-	28	PAO+	43	PULS+
14	PBO-	29	PBO+	44	PL
15	PZO-	30	PZO+	--	--

Table 4-17 CN2 interface definition of VD2A, VD2B and VD2C servo drive

(2) VD2-0xxSA1H drive control input and output pin distribution (CN2 interface)

Figure 4-14 VD2-0xxSA1H servo drive control input and output pin distribution

Pin number	Signal name	Pin number	Signal name	Pin number	Signal name
1	--	16	--	31	--
2	--	17	--	32	--
3	--	18	--	33	--
4	DOCOM	19	DOCOM	34	--
5	DO1+	20	DO3+	35	DOCOM
6	DOCOM	21	DOCOM	36	--
7	DO2+	22	DO4+	37	24V
8	SS	23	DI5	38	--
9	DI1	24	DI6	39	--
10	DI2	25	DI7	40	SIGN-
11	DI3	26	DI8	41	SIGN+
12	DI4	27	--	42	PULS-
13	--	28	--	43	PULS+
14	--	29	--	44	PL
15	--	30	--	--	--

Table 4-18 CN2 interface definition of VD2-0xxSA1H servo drive

(3) VD2F and VD2L servo drive control input and output pin distribution (CN2 interface)

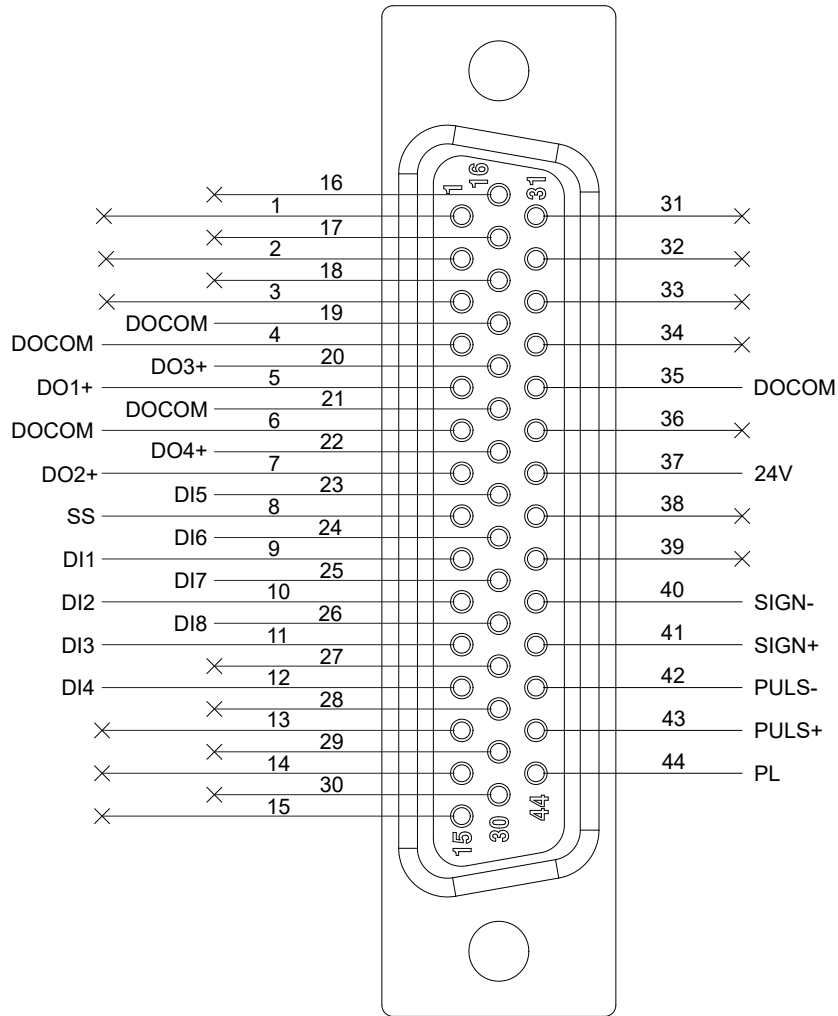
Figure 4-15 VD2F and VD2L servo drive control input and output pin distribution

Pin number	Signal name	Pin number	Signal name	Pin number	Signal name
1	DO3	6	DO4	11	PL
2	DO1	7	DO2	12	PULS+
3	SS	8	DOCOM	13	PULS-
4	DI3	9	DI4	14	SIGN+
5	DI1	10	DI2	15	SIGN-

Table 4-19 CN2 interface definition of VD2F and VD2L servo drive

4.4.2 Wiring diagram of each mode

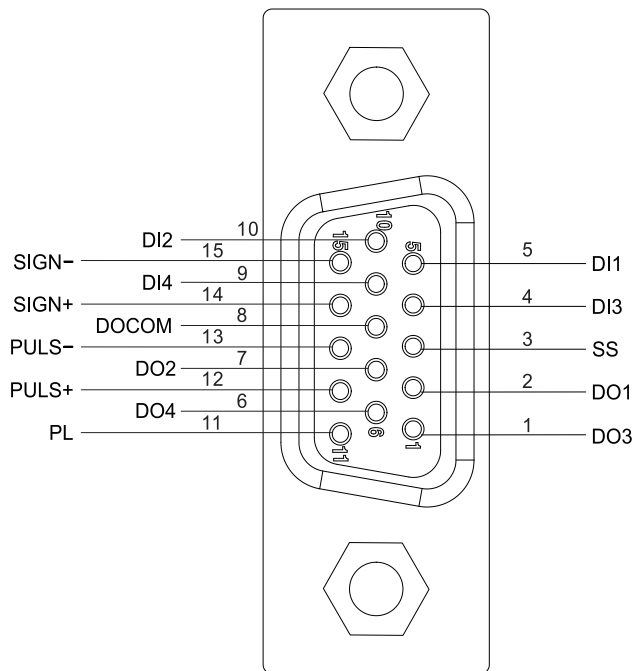
(1) VD2A, VD2B and VD2C servo drive

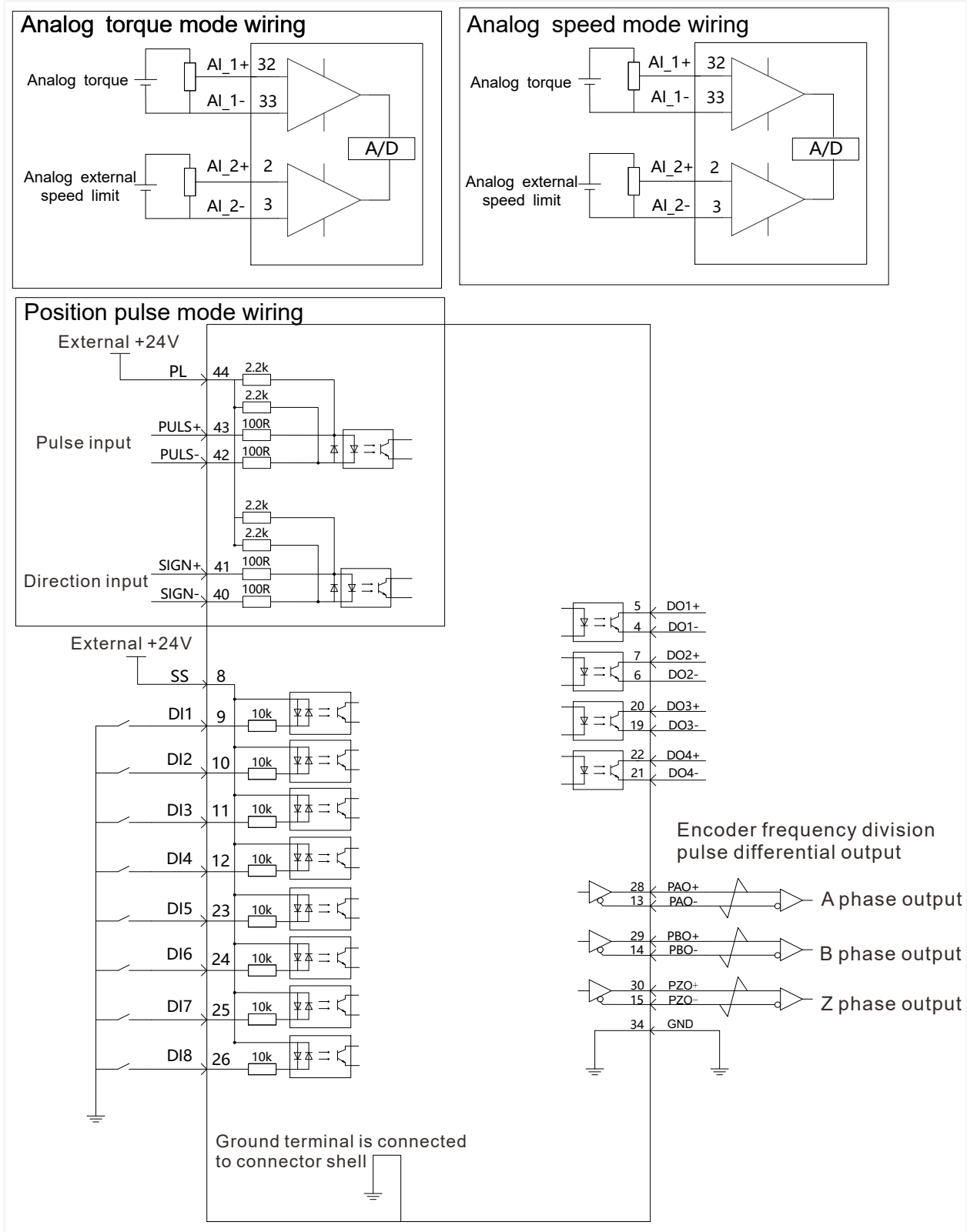

Figure 4-16 Wiring diagram of each mode

Note: Please refer to "4.4.1 Table 4-17 CN2 interface definition of VD2A and VD2B servo drive" for the pin numbers in the figure.

(2) VD2-0xxSA1H servo drive

Figure 4-17 Wiring diagram of each mode

Note: Please refer to "4.4.1 Table 4-18 CN2 interface definition of VD2A and VD2B servo drive" for the pin numbers in the figure.

(3) VD2F servo drive

Figure 4-18 Position pulse mode wiring

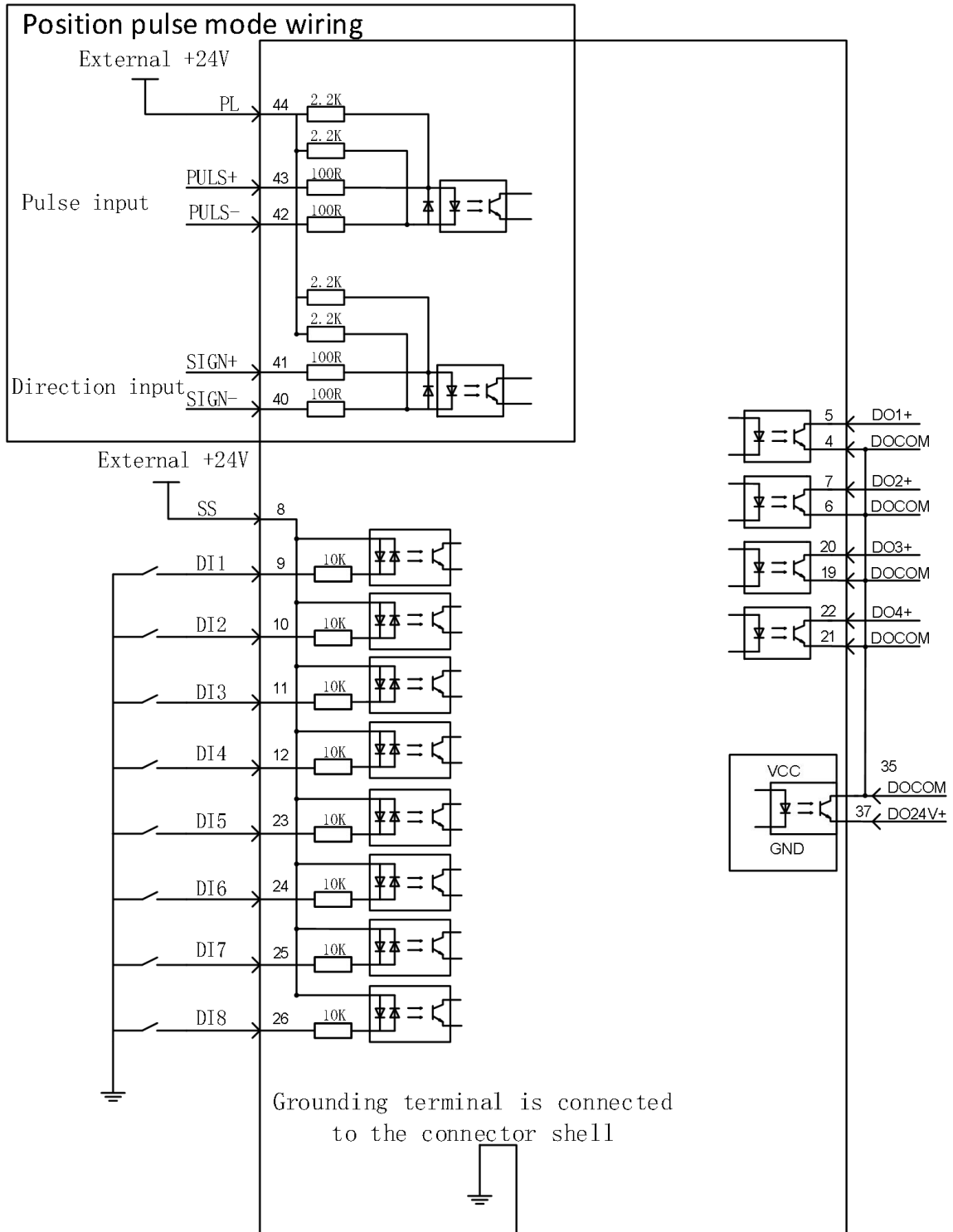
Note: Please refer to "[4.4.1](#) Table 4-19 CN2 interface definition of VD2F servo drive" for the pin numbers in the figure.

(4) VD2L servo drive

Position Pulse mode connection diagram

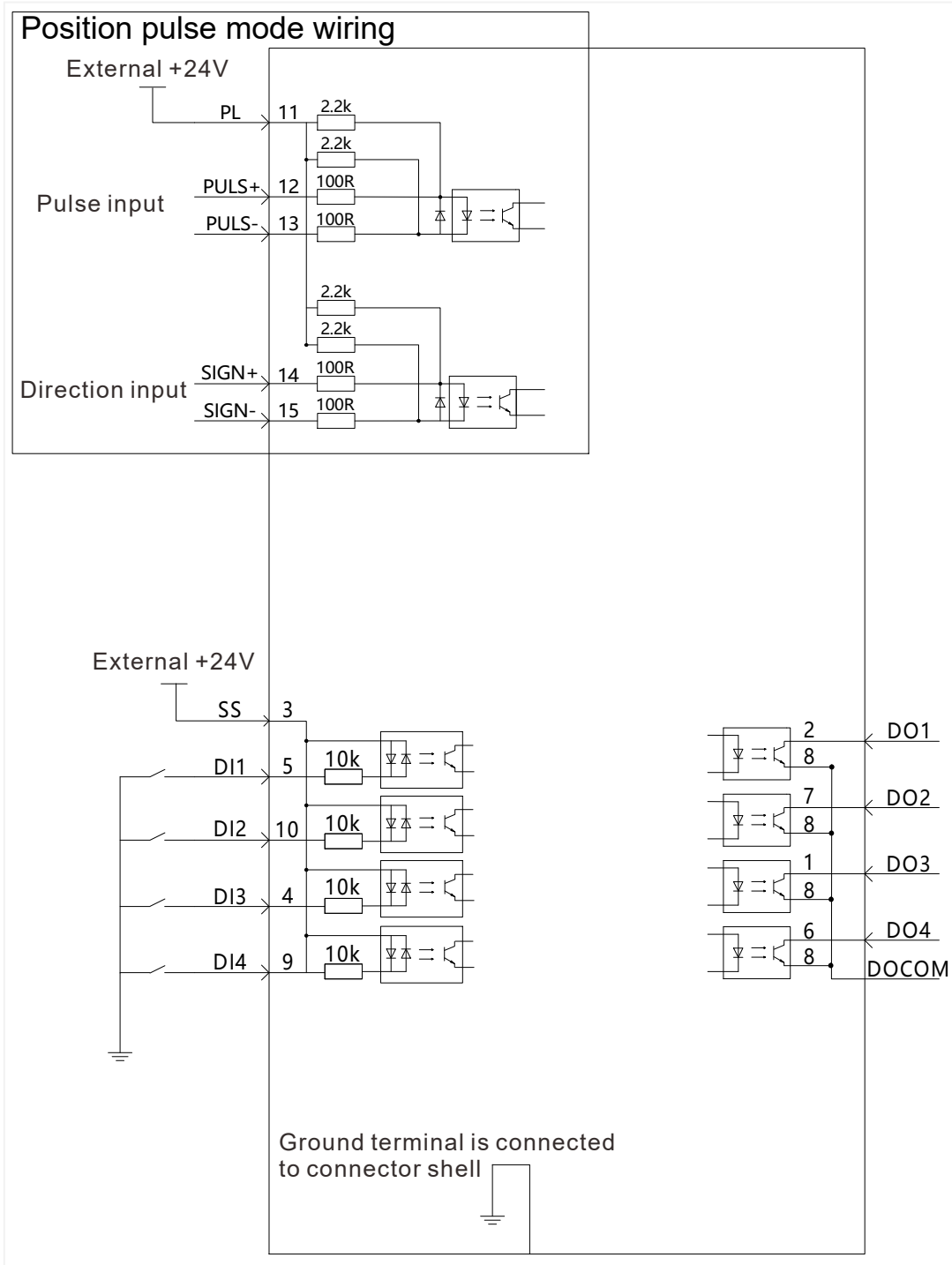
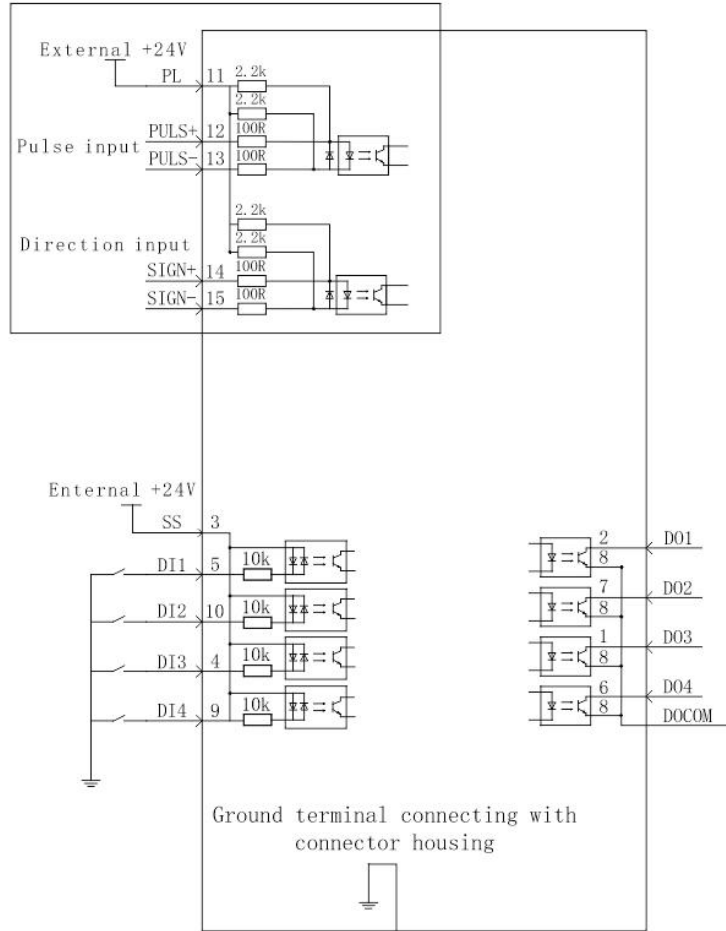

Figure 4-19 Position pulse mode wiring

🔧 Note: Please refer to "4.4.1 Table 4-19 CN2 interface definition of VD2F and VD2L servo drive" for the pin numbers in the figure.

4.4.3 Position instruction input signal

Signal name	Pin number					Functions
	VD2A	VD2B	VD2C	VD2F	VD2L	
PULS+	43			12		Low-speed pulse input modes: differential input, open collector. There are three types of input pulse: 1 Direction + pulse (positive logic) 2 CW/CCW (VD2F and VD2L not support yet) 3 A and B phase orthogonal pulses (4 times frequency).
PULS-	42			13		
SIGN+	41			14		
SIGN-	40			15		
PL	44			11		External power input interface for instruction pulse.

Table 4-20 Position instruction signal description

The instruction pulse and sign output circuit on the host device side can be selected from differential output or open collector output. The maximum input frequency is shown in the table.

Pulse method	Maximum frequency
Differential	500KHz
Open collector	200KHz

(1) Differential input

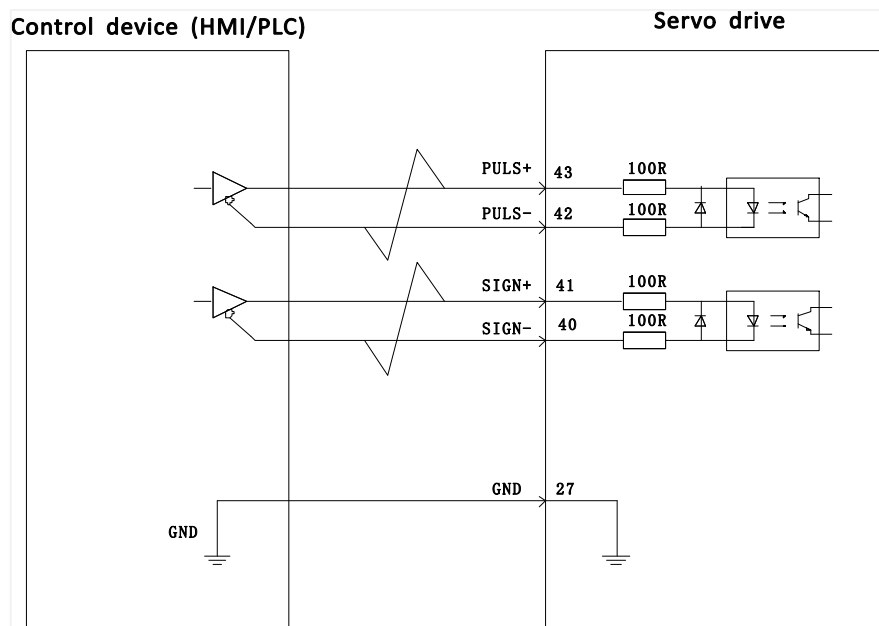

Figure 4-20 VD2A, VD2B and VD2C servo drive differential input connection

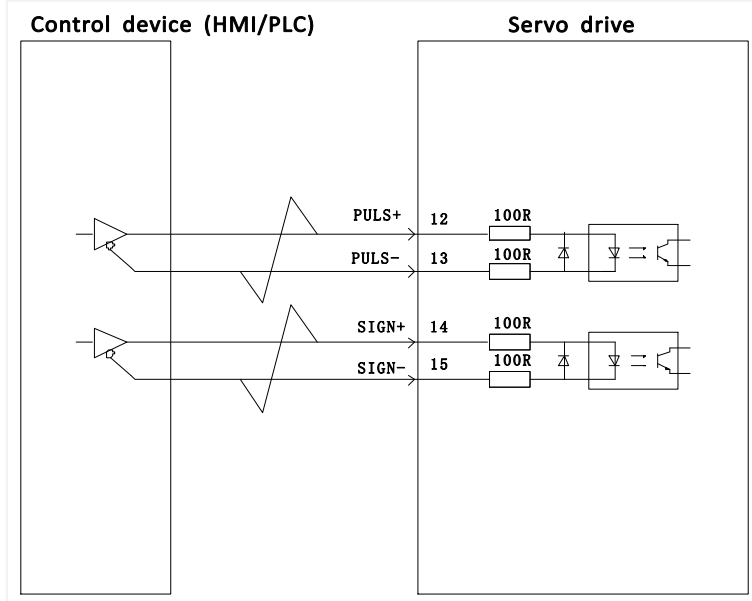

Figure 4-21 VD2F and VD2L servo drive differential input connection

(2) Open collector input

1) Open collector input connection

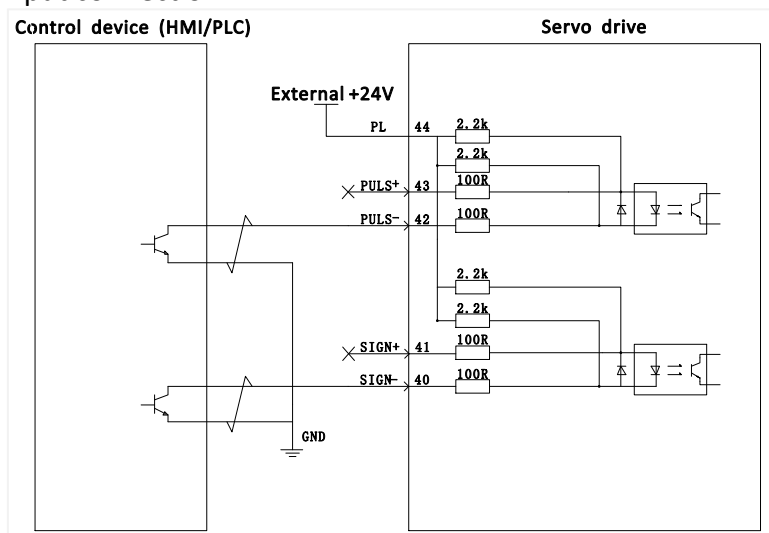

Figure 4-22 VD2A, VD2B and VD2C servo drive open collector input connection

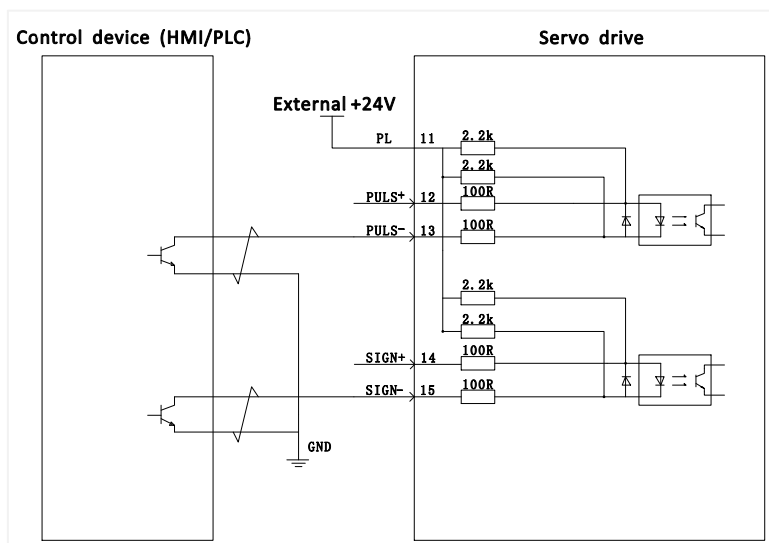

Figure 4-23 VD2F and VD2L servo drive open collector input connection

2) NPN and PNP wiring

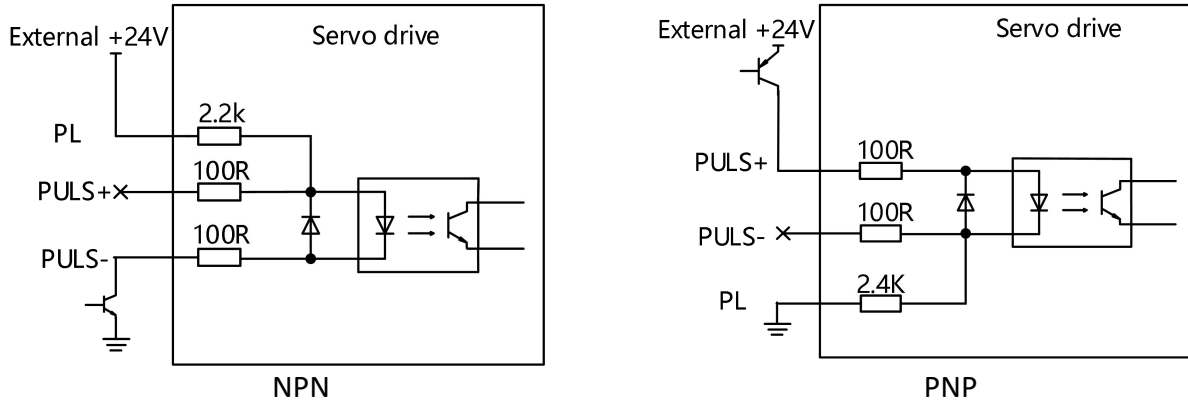

Figure 4-24 Triode wiring

4.4.4 Analog input signal

The analog input signal is only supported by VD2A, VD2B and VD2C servo drives.

Pin number	Signal name	Function
32	AI_1+	AI_1 analog input signal, resolution 12-bit. Input voltage range: -10V to +10V.
33	AI_1-	
2	AI_2+	AI_2 analog input signal, resolution 12-bit. Input voltage range: -10V to +10V.
3	AI_2-	
17	GND	Analog input signal ground.
34	GND	

Table 4-21 Analog input signal description

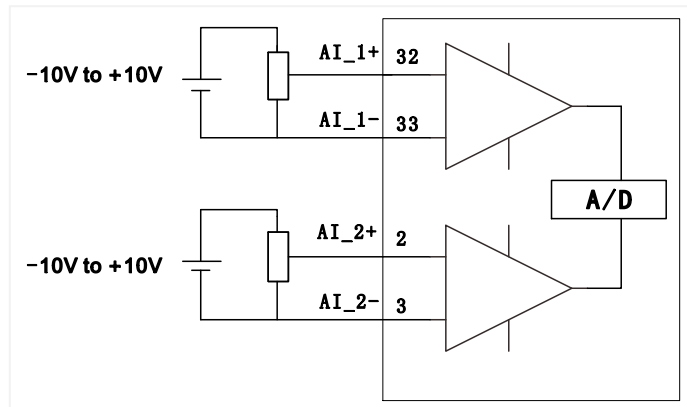

Figure 4-25 Analog input wiring

4.4.5 Digital input and output signals

(1) VD2A, VD2B and VD2C servo drives

Pin number	Signal name	Default function
9	DI1	Servo enable
10	DI2	Faults and alarms clearance
11	DI3	Forward drive prohibited
12	DI4	Reverse drive prohibited
23	DI5	Inverted instruction
24	DI6	Instruction pulse prohibited input
25	DI7	Not used
26	DI8	Not used
8	SS	Power input (24V)
4	DO1-	Rotation detection
5	DO1+	
6	DO2-	Fault signal
7	DO2+	
19	DO3-	Servo rdy
20	DO3+	
21	DO4-	Positioning completed
22	DO4+	

Table 4-22 DI/DO signal description

1) Digital input circuit

- ① When the control device (HMI/PLC) is relay output

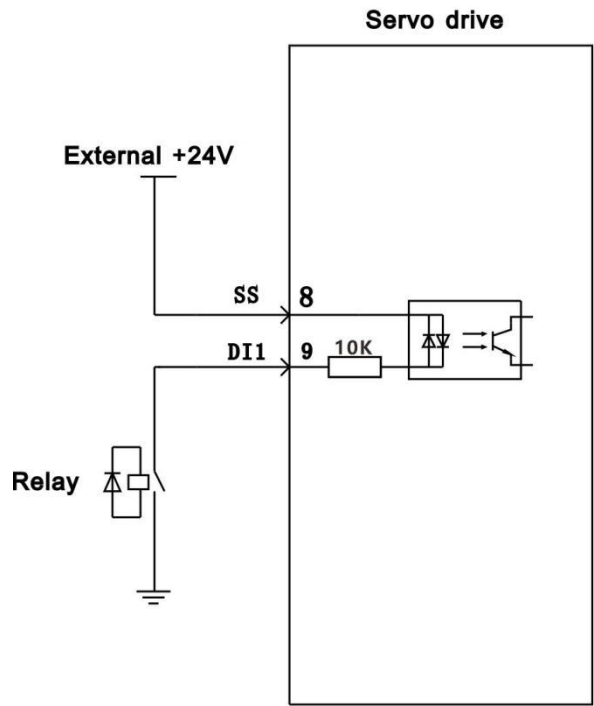

Figure 4-26 Relay output

- ② When the control device (HMI/PLC) is open collector output

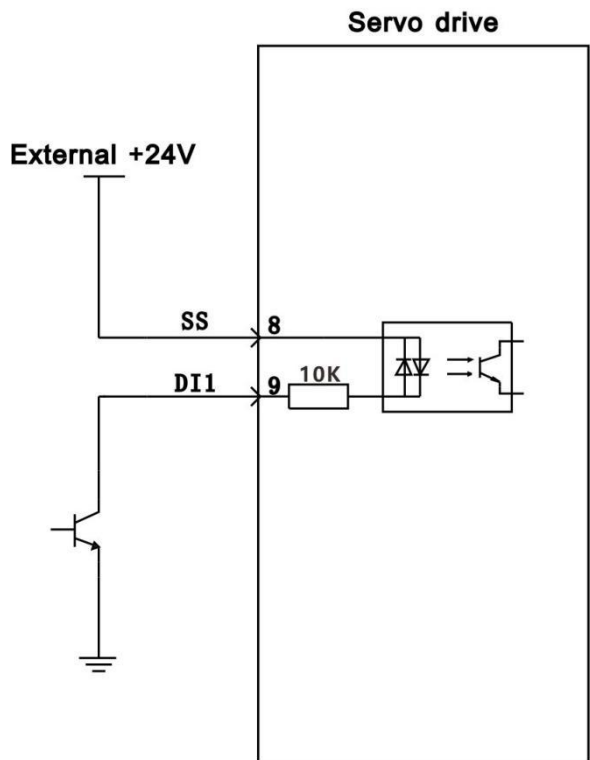

Figure 4-27 Open collector output

2) Digital output circuit

- ① When the control device (HMI/PLC) is relay input

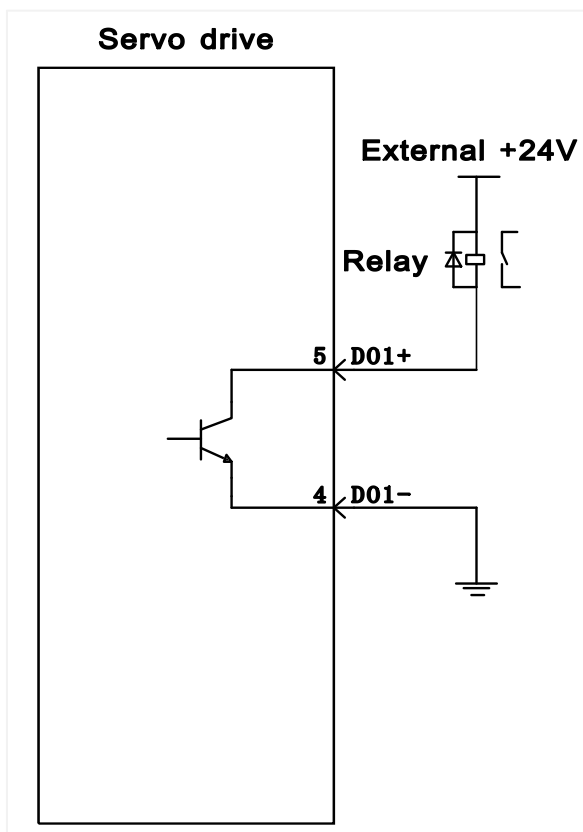
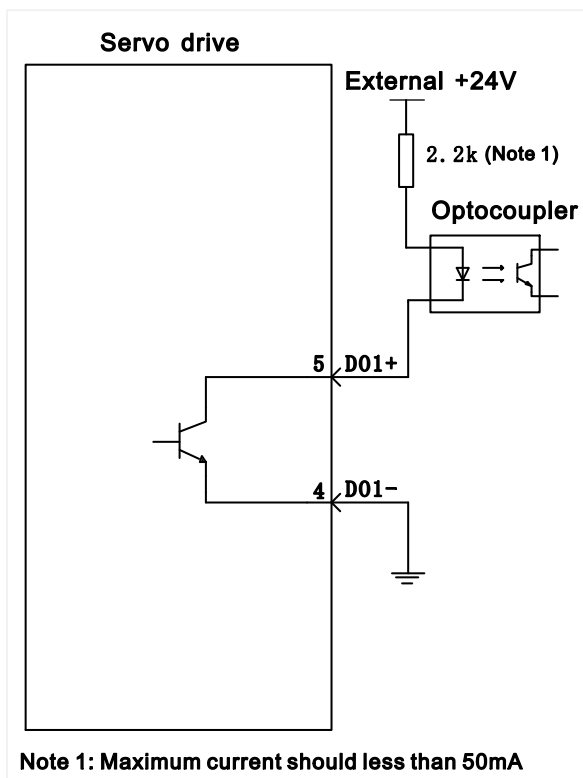

Figure 4-28 Relay input

- ② When the control device (HMI/PLC) is optocoupler input



Note 1: Maximum current should less than 50mA

Figure 4-29 Optocoupler input

(2) VD2-0xxSA1H servo drives

Pin number	Signal name	Default function
9	DI1	Servo enable
10	DI2	Fault and alarm clearance
11	DI3	Forward drive prohibited
12	DI4	Reverse drive prohibited
23	DI5	Inverted command
24	DI6	command pulse prohibited input
25	DI7	Not used
26	DI8	Not used
8	SS	Power input (24V)
5	DO1+	Fault signal
7	DO2+	Pulse frequency division output (Z phase)
20	DO3+	Pulse frequency division output (A phase)
22	DO4+	Pulse frequency division output (B phase)
4/6/19/21/35	DOCOM	DO Power Common (0V)
37	24V+	DO power input (24V)

Table 4-23 DI/DO signal description

1) Digital output circuit

- ① When the control device (HMI/PLC) is relay input

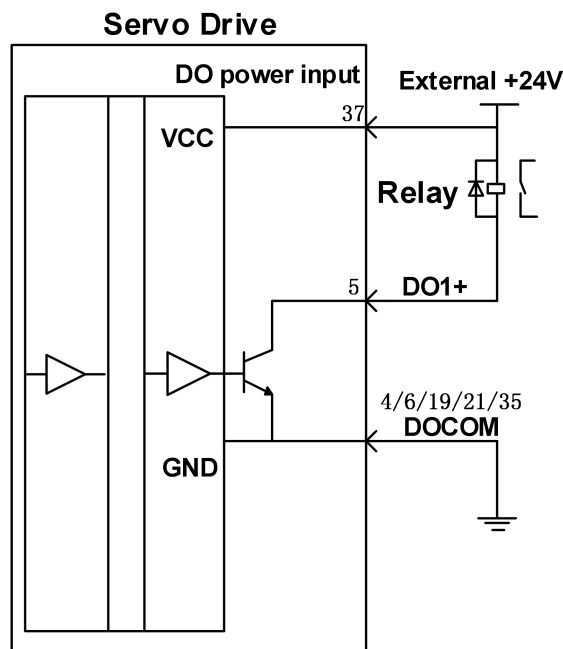
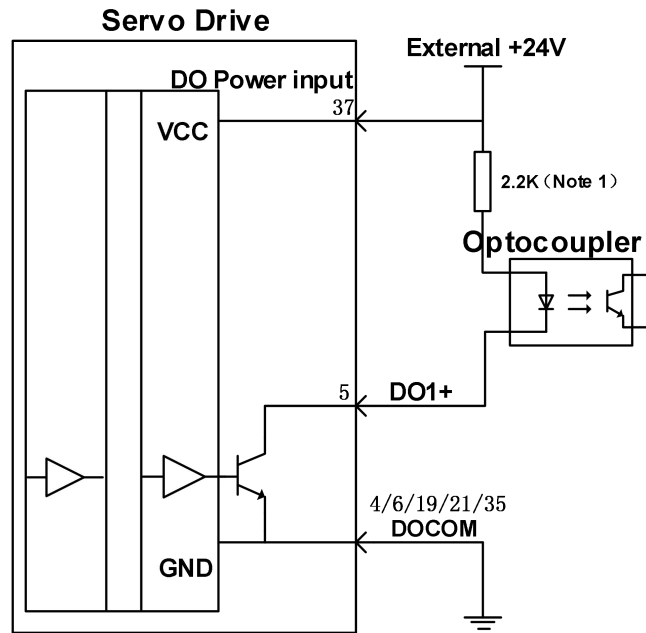

Figure 4-30 Relay input

- ② When the control device (HMI/PLC) is optocoupler input



(Note: Maximum current should less than 750mA)

Figure 4-31 Optocoupler input

- 2) The digital output circuit wiring of VD2-0xxSA1H Servo Drive is different from that of VD2A and VD2F servo drives. VD2-0xxSA1H needs to be connected to external 24V DC power supply. (CN2_35 pin and CN2_37 pin is connected to COM0 and 24V+ of external 24V power supply respectively). If the access current is too large and the DOCOM line is relatively thin, servo drives need to access multiple DOCOM to achieve the shunt effect.

(3) VD2F and VD2L servo drives

Pin number	Pin name	Default function
5	DI1	Servo enable
10	DI2	Faults and alarms clearance
4	DI3	Forward drive prohibited
9	DI4	Reverse drive prohibited
3	SS	Power input (24V)
2	DO1	Rotation detection
7	DO2	Fault signal
1	DO3	Servo rdy
6	DO4	Positioning completed
8	DOCOM	DO common terminal

Table 4-24 DI/DO signal description

1) Digital input circuit

- ① When the control device (HMI/PLC) is relay output

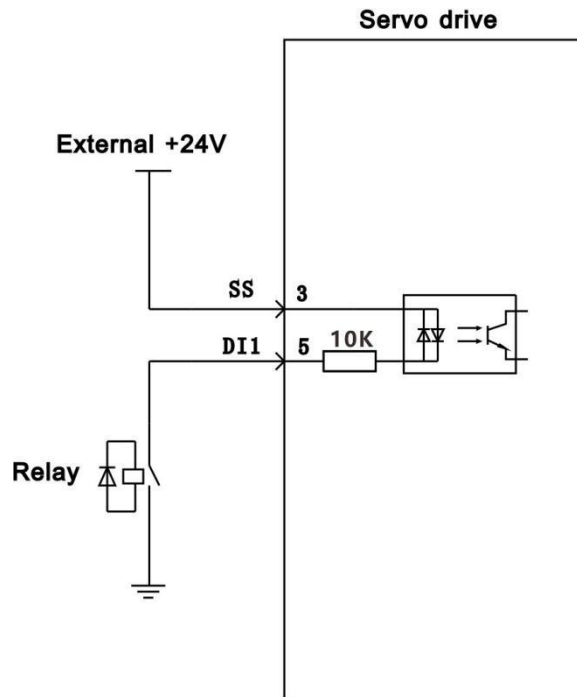

Figure 4-32 Relay output

- ② When the control device (HMI/PLC) is open collector output

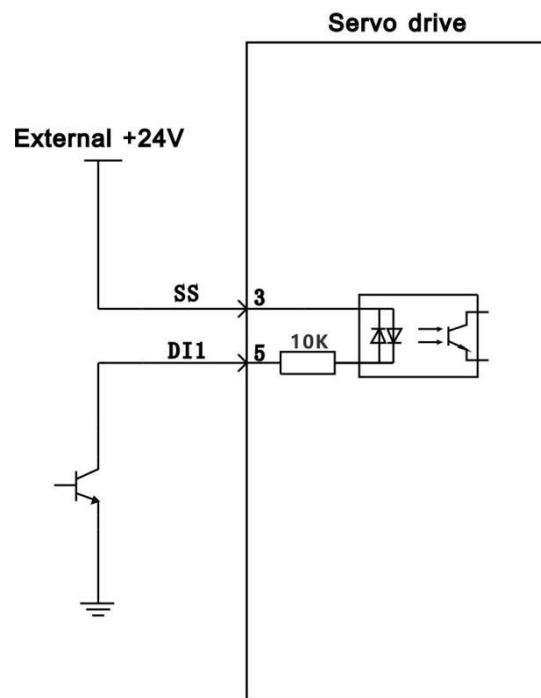

Figure 4-33 Open collector output

2) Digital output circuit

- ① When the control device (HMI/PLC) is relay input

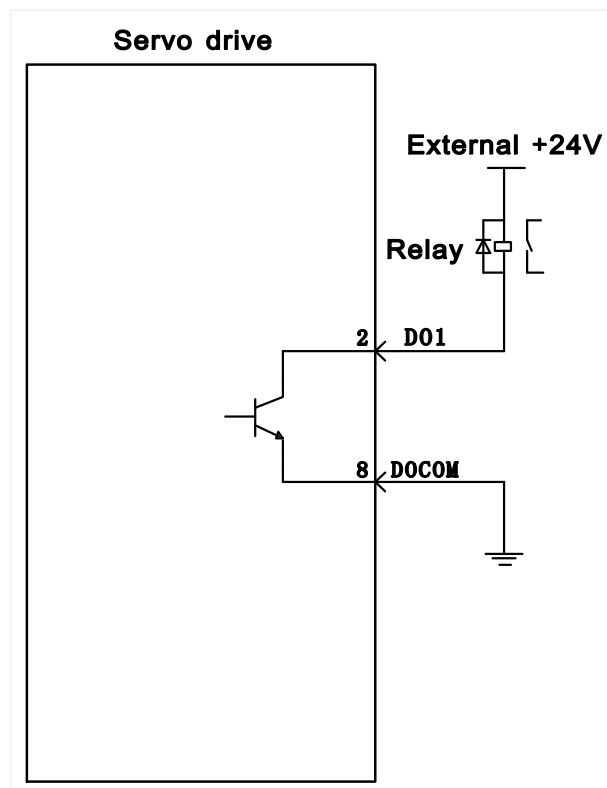

Figure 4-34 Relay output

② When the control device (HMI/PLC) is optocoupler input

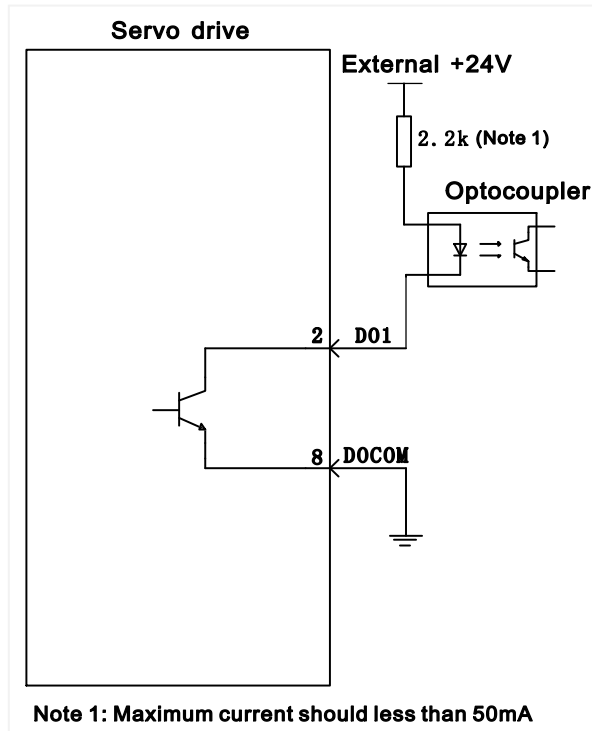

Figure 4-35 Optocoupler input

4.4.6 Brake wiring

The brake is a mechanism that prevents the servo motor shaft from moving when the servo drive is in a non-running state, so that the motor remains in position lock, so that the moving part of the machinery will not move due to self-weight or external force.

Brake input signal is no polar. You need to use 24V power. The standard wiring between brake signal BK and brake power is as below.

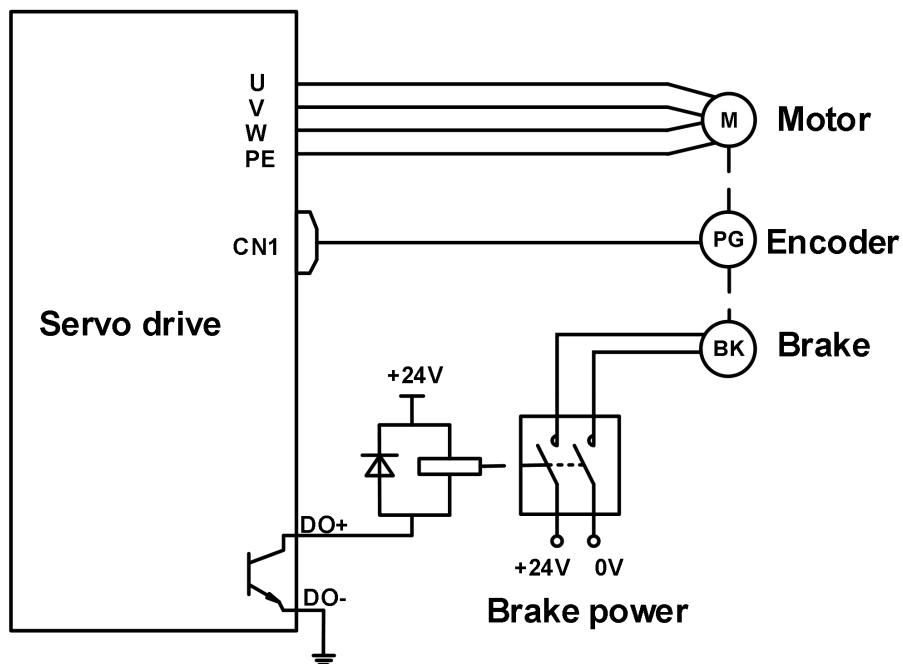

Figure 4-36 Brake wiring of VD2A, VD2B and VD2C

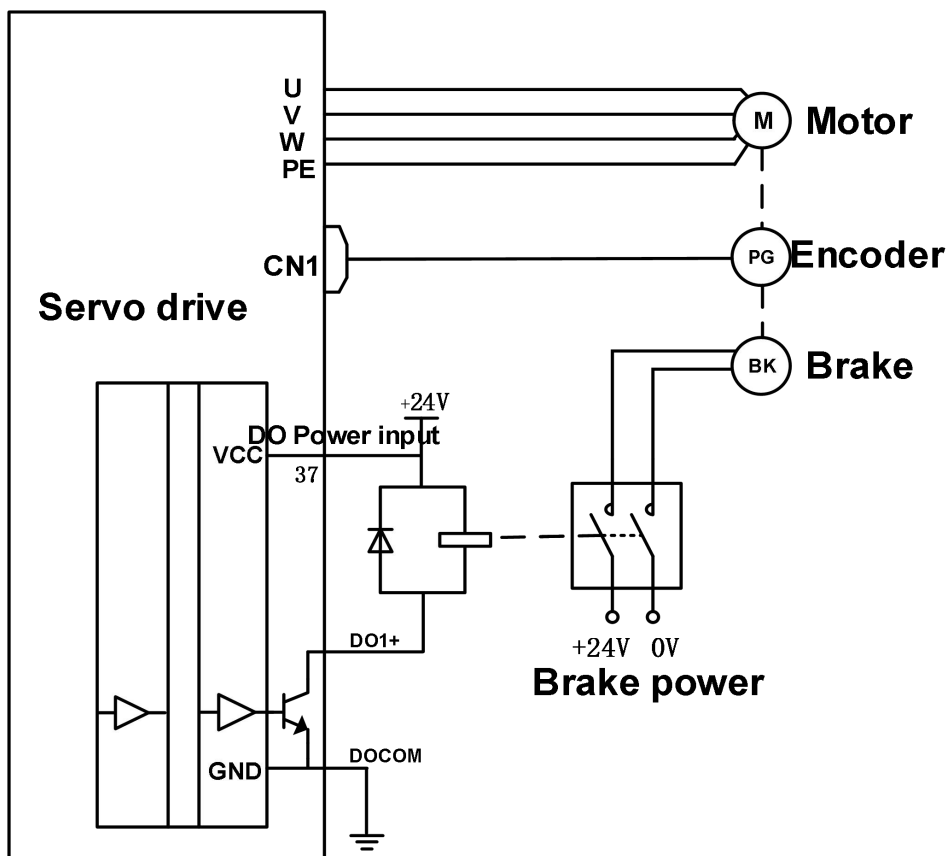

Figure 4-37 Brake wiring of VD2-0xxSA1H

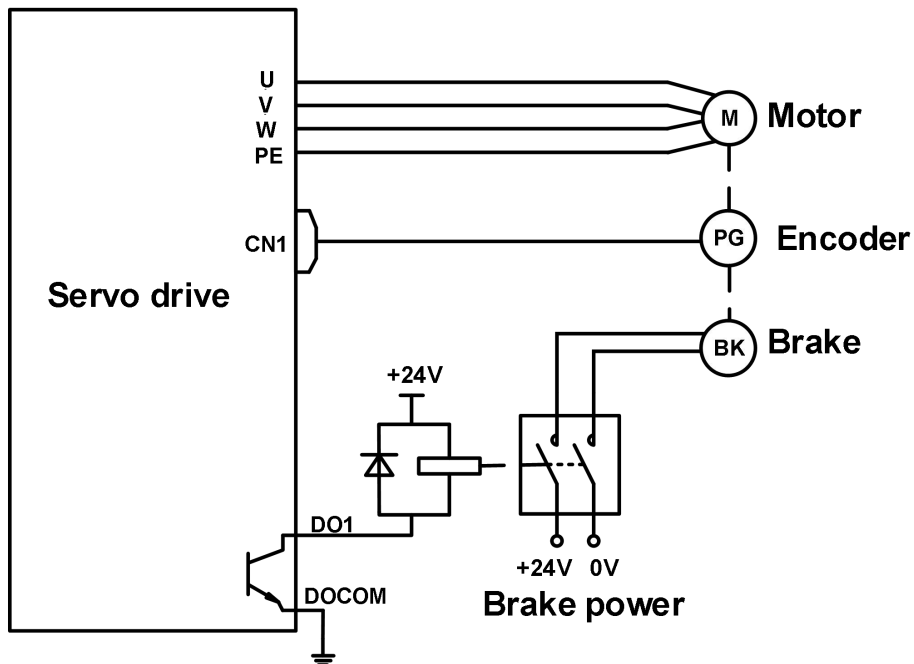

Figure 4-38 Brake wiring of VD2F and VD2L

4.5 Communication signal wiring

Wecon VD2 series servo drive supports two communication modes: RS-422 and RS-485. The communication port is RJ45 socket. The exterior of communication terminal is shown in Figure 4-35.

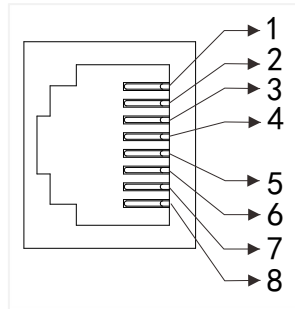

Figure 4-39 Pin number of an RJ45 socket

The communication modes supported by the driver communication ports are in the following table.

VD2 A, VD2 B and VD2 C		VD2F	
Port	Communication mode	Port	Communication mode
CN3	Only RS422	CN3	RS422, RS485 communication mode choose one of two. Set by function code P12-05
CN5	Only RS485	CN4	
CN6		Note: The CN5 and CN6 interfaces are physically connected and are actually the same communication interface.	Note: The CN3 and CN4 interfaces are physically connected and are actually the same communication interface. When P12-05 is set to 1, CN3 and CN4 use RS485 communication mode. If the value is set to 0, both use RS422 communication mode.

Table 4-25 Communication port communication modes

VD2L	
Port	Communication mode
USB	Only control device (PLC and HMI)
CN3	Only RS485
CN4	
Note: The CN5 and CN6 interfaces are physically connected and are actually the same communication interface.	

4.5.1 Communication connection with servo host computer (RS422)

Servo drives communicate with the host computer via RS422 communication. A USB to RS422 (RJ45 connector) cable is required for communication, and you need to equip it by yourselves.

(1) VD2A&VD2B

VD2A and VD2B servo drives communicate with the host computer via the CN3 interface by RS422 communication. [Figure 4-36](#) and [Figure 4-37](#) show the communication connections.

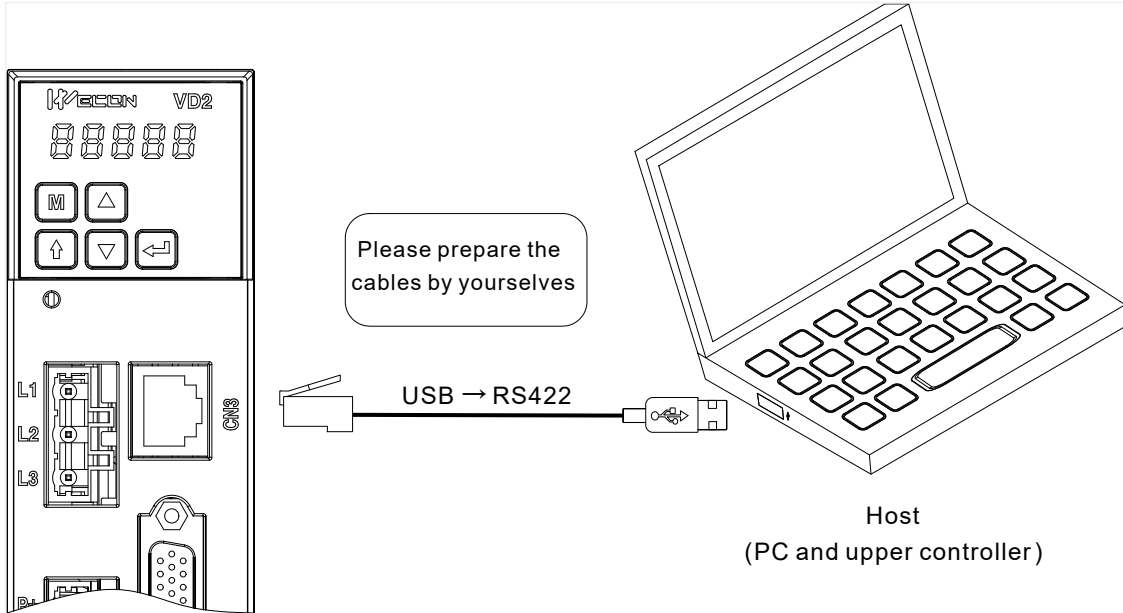

Figure 4-40 The Connection between VD2A drive and PC

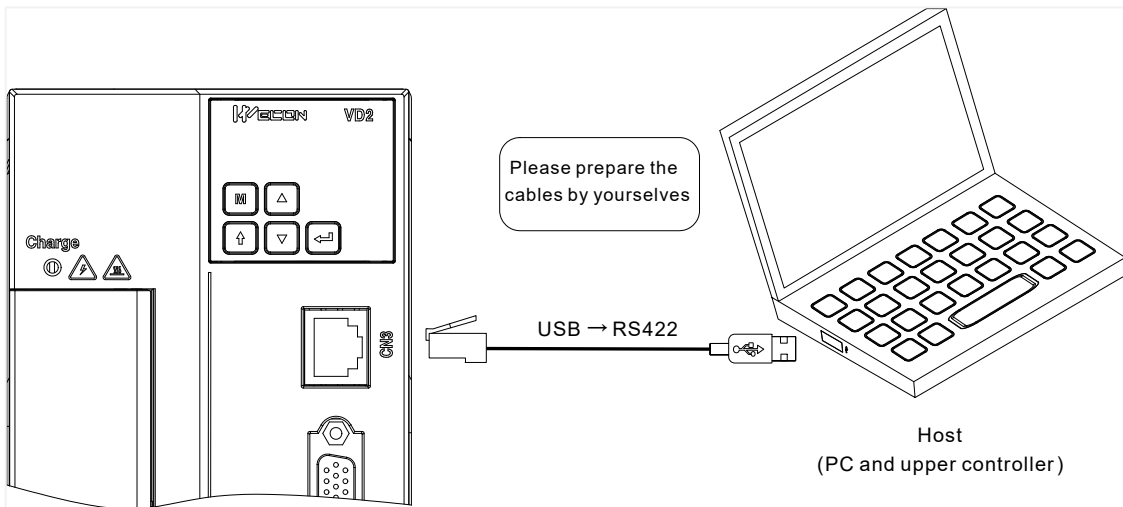

Figure 4-41 The connection between VD2B and VD2C drive and PC

CN3	Pin	Name	Function description
	1	RX-	Computer sends negative terminal (drive receives negative)
	2	RX+	Computer sends positive terminal (drive receives positive)
	3	TX-	Computer receives negative terminal (drive sends negative)
	4	GND	Ground terminal
	5	NC	Not used
	6	TX+	Computer receives positive terminal (drive sends positive)
	7	NC	Not used
	8	NC	Not used

Table 4-26 VD2A and VD2B pin definitions for CN3

(2) VD2F

VD2F servo drive communicates with the host computer via the CN3 or CN4 interface byRS422 communication. The communication diagrams of VD2F servo drive and host computer are shown in [Figure 4-38](#).

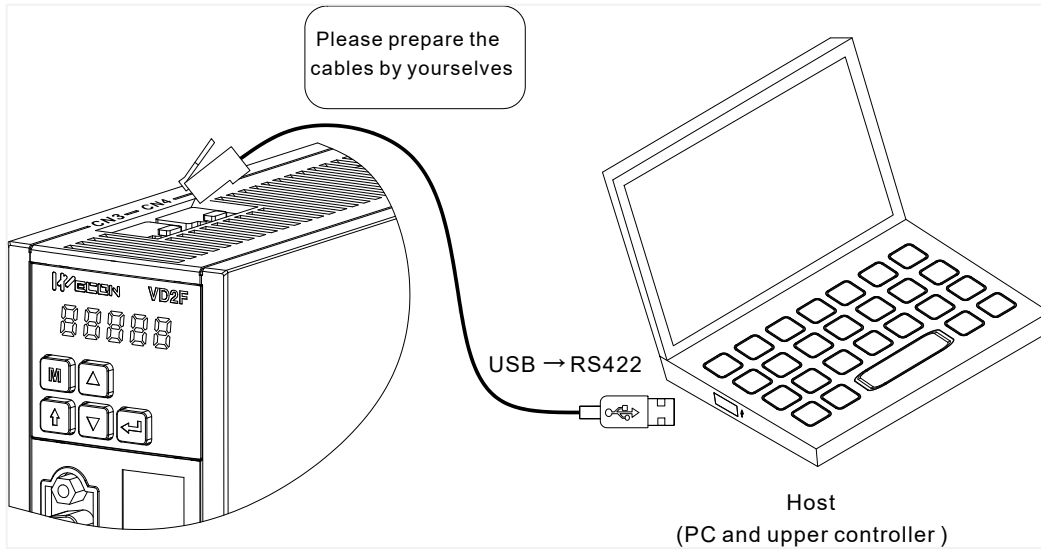

Figure 4-42 The connection between VD2F drive and PC

CN3&CN4	Pin	Name	Function description
	1	RX-	Computer sends negative terminal (drive receives negative)
	2	RX+	Computer sends positive terminal (drive receives positive)
	3	TX-	Computer receives negative terminal (drive sends negative)
	4	GND	Ground terminal
	5	NC	Not used
	6	TX+	Computer receives positive terminal (drive sends positive)
	7	NC	Not used
	8	NC	Not used

Table 4-27 VD2F pin definitions for CN3/CN4 interfaces

(3) VD2L

VD2F servo drive communicates with the host computer via the CN3 or CN4 interface byRS422 communication. The communication diagrams of VD2F servo drive and host computer are shown in [Figure 4.43](#).

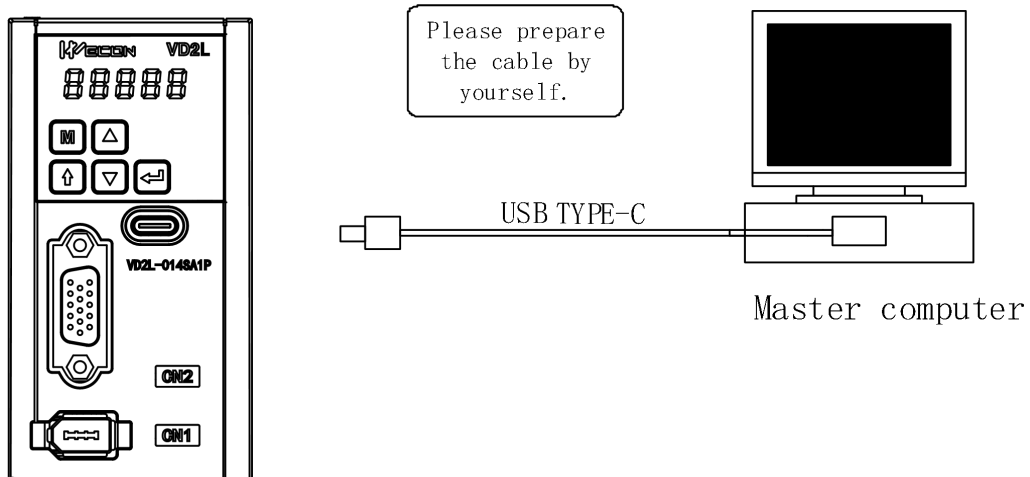

Figure 4-43 The connection between VD2F drive and PC

4.5.2 Communication connection with PLC and other device (RS485)

VD2A, VD2B and VD2C servo drives communicate with PLC and other devices for Modbus via CN5 or CN6 interface (located on the top of servo drive) by RS485 communication.

CN5&CN6	Pin	Name	Function description
	1	485+	Computer sends negative terminal (drive receives negative)
	2	485-	Computer sends positive terminal (drive receives positive)
	3	NC	Not used
	4	GND	Ground terminal
	5	GND	Ground terminal
	6	NC	Not used
	7	Reserved	Reserved
	8	GND	Ground terminal

Table 4-28 VD2A, VD2B and VD2C pin definitions for CN5/CN6 interfaces

VD2F and VD2L servo drives communicate with PLC and other devices for Modbus via CN3 or CN4 interface (located on the top of servo drive) by RS485 communication.

CN3&CN4	Pin	Name	Function description
	1	485+	Computer sends negative terminal (drive receives negative)
	2	485-	Computer sends positive terminal (drive receives positive)
	3	-	Computer receives negative terminal
	4	GND	Ground terminal
	5	-	Not used
	6	-	Computer receives positive terminal
	7	-	Not used
	8	-	Not used

Table 4-29 VD2F and VD2L pin definitions for CN3/CN4 interfaces

5. Panel

5.1 Panel composition

The panel composition of the VD2 series servo drive is shown in Figure 5-1. (take VD2A servo drive as an example).

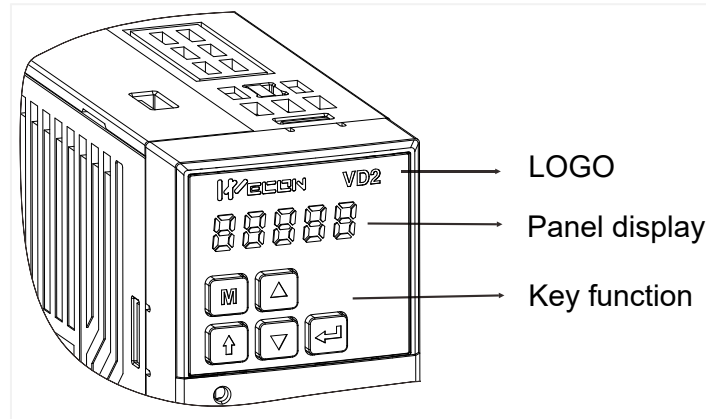

Figure 5-1 The exterior of VD2 A servo drive panel

The panel of the VD2 series servo drive consists of a display (5-digit LED nixie tube) and keys, which can be used for the execution of various displays, parameter settings and other functions of the servo drive. Taking parameter setting as an example, the general functions of the keys are shown in [Table 5-1](#).

Icon	Name	Function
	Mode	① Mode switching ② Return to the previous menu
	Increase	Increase the value of the LED flashing bit
	Decrease	Decrease the value of the LED flashing bit
	SHIFT key	① Change the LED flashing bit ② View the high-bit value of data with a length greater than 4-bit
	Enter (OK)	① Enter the next menu ② Execute commands such as storing parameter setting values

Table 5-1 Key functions

5.2 Panel display

When servo drive is in operation, the panel could be used for status display, parameter display, fault display and monitoring display of the servo.

Status display: Display the current operating status of servo drive.

Parameter display: Display the function codes corresponding to different functions and the set values of the function codes.

Fault display: Display the fault code of servo drive.

Monitor display: Display the current operating parameter values of servo drive.

5.2.1 Display switching

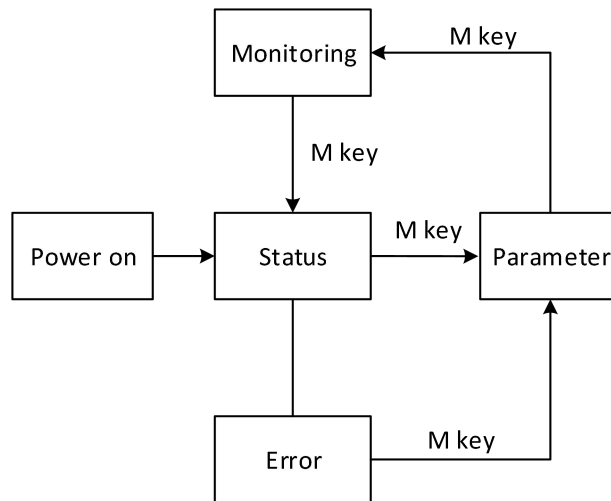

Figure 5-2 Switch between display types on the panel

Illustrate:

- ① The power is turned on, and the panel display of the servo drive enters “Status Display Mode”.
- ② After an operation failure occurs, the panel immediately switches to the bit failure display mode. At this time, all the nixie tubes flash synchronously. Press the "mode" key to switch to the parameter display mode.
- ③ Press the "Mode" key to switch between different display modes, and the switching conditions are shown in Figure 5-2.

5.2.2 Status display

Display	Display occasion	Meaning
	Servo drive is powered on within 1 second	Servo drive is in initialization status
	Very short time after displaying "88888"	Initialization is complete
	1 second after servo drive is powered on, servo is ready	The servo is ready, waiting for the enable signal given by servo drive
	Servo enable signal is valid	The servo drive is in an operational status, waiting for the instructions from host computer
	Servo drive is in jog operation	Jog operation settings

Table 5-2 Status display example

5.2.3 Parameter display

VD2 series servo drive is divided into 13 groups of function codes according to different parameter functions, which could quickly locate the position of function codes according to the function code groups. For specific parameters refer to [“9 Parameters”](#).

(1) Parameter group display

The parameter display is the display of different function codes. The format of the function code is "PXX.YY". "PXX" indicates the group number of function code, and "YY" indicates the number within the function code group.

Display	Name	Content
PXX.YY	Function code group number	Number in function code group

For example: The function code P00.01 is displayed as follows.

Display	Name	Content
	Function code P00.01	00: Function code group number 01: Number in the function code group

(2) Display of different length data

1) Display Data with four bits and below

Using single page display, if it is a signed number, the highest bit of the data is "-".

For example: The monitoring volume U0-02 is displayed as follows.

Display	Name	Content
	Monitoring volume U0-02	Servo motor speed

2) Display Data more than five bits

Display in pages from low to high bits, and each 4 bits is a page. Display method: current page + current value. As shown in [Figure 5-3](#) and [Figure 5-4](#), switch current page by pressing the "shift" key.

For example: 2147483646 is displayed as follows:

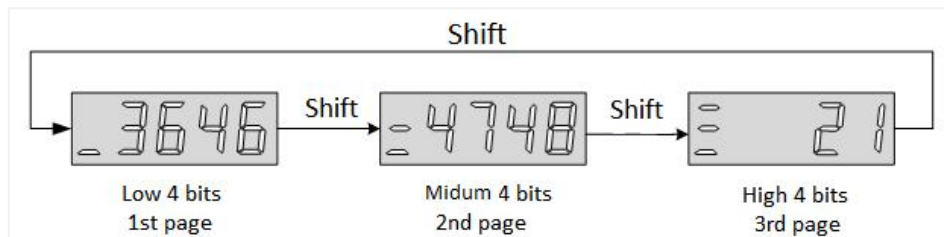

Figure 5-3 2147483646 display operation

For example: -2147483647 is displayed as follows:

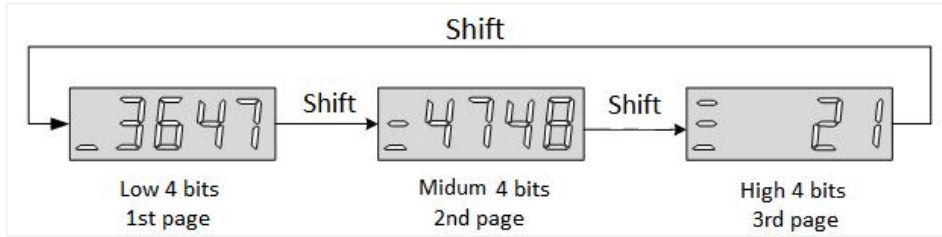

Figure 5-4 -2147483647 display operation

(3) Decimal point display

The "." of the one-digit indicates the decimal point, and it does not flash. The example is as follows.

Display	Name	Content
	Decimal point	302.4

(4) Parameter setting display

Display	Name	Display occasion	Meaning
	Done Parameter setting completed	Parameter reset factory	The servo drive is in the process of parameter factory reset
	P.Init Parameter reset factory	Parameter reset factory	The servo drive is in the process of parameter factory reset
	Error Parameter error	Parameter setting exceeds the limit (or not allowed to exceed the limit)	Prompt that the parameter setting exceeds the limit

Table 5-3 Parameter setting display

5.2.4 Fault display

The panel can display current or historical fault and warning codes. For analysis and troubleshooting of faults and warnings, please refer to ["10 Faults"](#).

When a single fault or warning occurs, the panel immediately displays the current fault or warning code; when multiple faults or warnings occur, the highest fault code is displayed. When a fault occurs, when switching from the auxiliary function to the parameter display function, the corresponding fault or warning code will be displayed. You can view the current fault and warning codes and the past five fault and warning codes through the monitor display on the panel.

Display	Name	Content
	Parameter modification that needs to be powered on again	Modified the parameters that need to be re-powered to take effect

Table 5-4 Warning display example

Display	Name	Content
	Motor overload protection	Motor overload protection

Table 5-5 Fault display example

5.2.5 Monitor display

After the servo drive is powered on or the servo enable is ON, you can press the "Mode" key to enter the monitor display mode.

Display	Monitoring volume	Name	Unit	Meaning
	U0-02	Servo motor speed	rpm	Indicates the actual operating speed of servo motor, expressed in decimal.
	U0-31	Bus voltage	V	Indicates the voltage value between P+ and - of the drive, DC bus voltage
	U0-17	Input signal status	-	Indicates the level status corresponding to the 8 DI terminals. The upper half of the LED light indicates high level, and the lower half light indicates low level. (The VD2F model has only 4 DI ports)
	U0-19	Output signal status	-	Indicates the level status corresponding to the 4 DO terminals. The upper half of the LED light indicates high level, and the lower half light indicates low level.

Table 5-6 Monitoring volume display example

5.3 Panel operation

5.3.1 Parameter setting

Use the servo drive panel to set the parameters. For details about the parameters, please refer to "[9 Parameters](#)". Take P00.01 as an example to set the parameters to change the control mode of the servo drive from position control mode to speed control mode. The setting steps are shown in [Figure 5-5](#).

Illustrate:

- ① The power supply is in Rdy state after power on.
- ② Press "Mode" key to enter the function code parameter interface.
- ③ Press "Confirm" key to enter the function code value modification interface after completing the function code selection.
- ④ Press the "Up" and "Down" keys to modify the parameter value.
- ⑤ Press the "Confirm" key twice to complete the value modification.

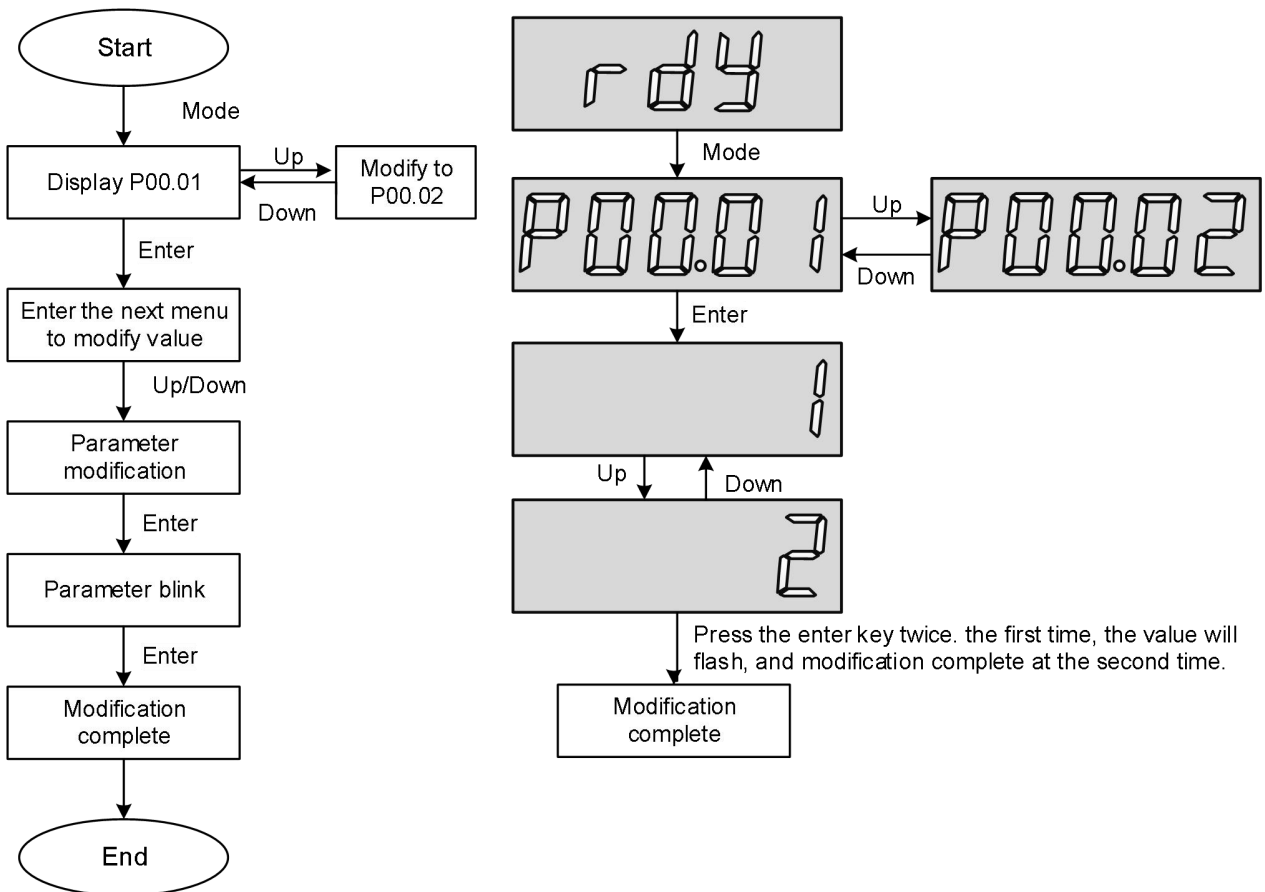

Figure 5-5 Schematic diagram of parameter setting steps

5.3.2 Jog operation

In order to test run the servo motor and the servo drive, you can use the jog running function. The operation steps are shown in [Figure 5-6](#).

Illustrate:

- ① Adjust the function code to P10.01 after power on.
- ② Press the "Enter" key to enter the next menu to set the JOG jog speed.
- ③ After the "JOG jog speed" setting is completed, press the "Enter" key, the panel displays "JOG" in a flashing state, press the "Enter" key again to enter the JOG mode.
- ④ Long press the "Up" key and "Down" key to realize the forward and reverse rotation of the motor.
- ⑤ Press the "Mode" key to exit the JOG mode.
- ⑥ Reason for displaying Error: Please refer to "[10 Faults](#)" according to the corresponding fault codes.

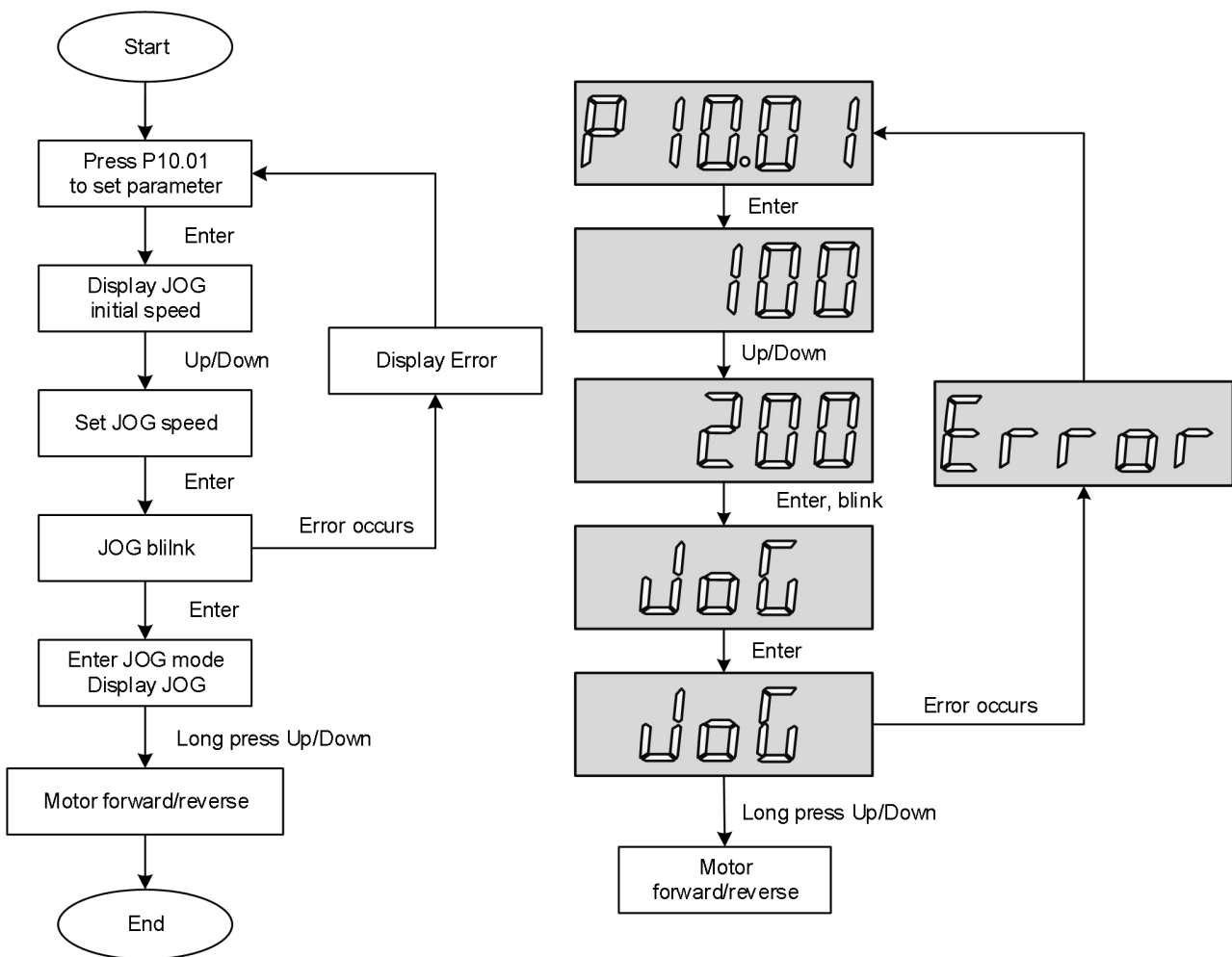

Figure 5-6 Jog operation setting steps

5.3.3 Factory reset

The factory settings can be restored through the servo drive panel. The specific operation steps are shown in [Figure 5-7](#).

Illustrate:

- ① After power on, modify the function code to P10.02.
- ② Press the "Enter" key to enter the next menu to set the parameters.
- ③ Press the "Confirm" button after the parameter setting is finished, and the setting value will flash.
- ④ Press "Confirm" again, the panel digital tube will light up gradually from left to right until 8.8.8.8.8 is displayed.
- ⑤ Finally, it displays "Done", the servo drive will be re-powered and the operation of factory reset is finished.

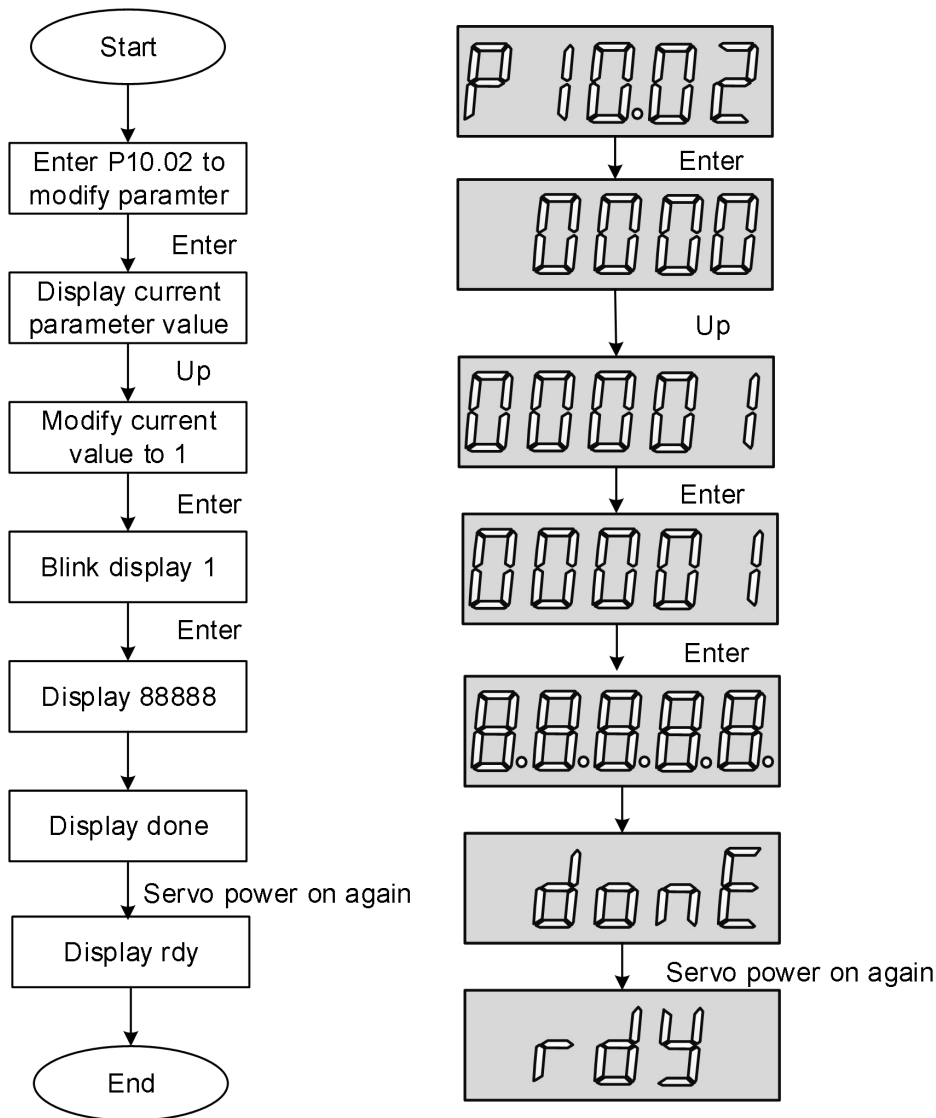

Figure 5-7 Steps for restoring factory settings

6. Operation

6.1 Basic settings

6.1.1 Check before operation

No.	Content
Wiring	
1	The main circuit input terminals (L1, L2 and L3) of servo drive must be properly connected.
2	The main circuit output terminals (U, V and W) of servo drive and the main circuit cables (U, V and W) of servo motor must have the same phase and be properly connected.
3	The main circuit power input terminals (L1, L2 and L3) and the main circuit output terminals (U, V and W) of servo drive cannot be short-circuited.
4	The wiring of each control signal cable of servo drive is correct: The external signal wires such as brake and overtravel protection have been reliably connected.
5	Servo drive and servo motor must be grounded reliably.
6	When using an external braking resistor, the short wiring between drive C and D must be removed.
7	The force of all cables is within the specified range.
8	The wiring terminals have been insulated.
Environment and Machinery	
1	There are no iron filings, metal, etc. that can cause short circuits inside or outside the servo drive.
2	The servo drive and external braking resistor are not placed on combustible objects.
3	The installation, shaft and mechanical structure of the servo motor have been firmly connected.

Table 6-1 Check contents before operation

6.1.2 Power-on

(1) Connect the main circuit power supply

After power on the main circuit, the bus voltage indicator shows no abnormality, and the panel display "rdy", indicating that the servo drive is in an operational state, waiting for the host computer to give the servo enable signal.

If the drive panel displays other fault codes, please refer to "10 Faults" to analyze and eliminate the cause of the fault.

(2) Set the servo drive enable (S-ON) to invalid (OFF)

6.1.3 Jog operation

Jog operation is used to judge whether the servo motor can rotate normally, and whether there is abnormal vibration and abnormal sound during rotation. Jog operation can be realized in two ways, one is panel jog operation, which can be realized by pressing the buttons on the servo panel. The other is jog operation through the host computer debugging platform.

(1) Panel jog operation

Enter "P10-01" by pressing the key on the panel. After pressing "OK", the panel will display the current jog speed. At this time, you can adjust the jog speed by pressing the "up" or "down" keys;

After adjusting the moving speed, press "OK", and the panel displays "JOG" and is in a flashing state. Press "OK" again to enter the jog operation mode (the motor is now powered on!). Long press the "up" and "down" keys to achieve the forward and reverse rotation of the motor. Press "Mode" key to exit the jog operation mode. For operation and display, please refer to ["5.3.2. Jog operation"](#).

(2) Jog operation of servo debugging platform

Open the jog operation interface of the software "Wecon SCTool", set the jog speed value in the "set speed" in the "manual operation", click the "servo on" button on the interface, and then achieve the jog forward and reverse function through the "forward rotation" or "Reverse" button on the interface. After clicking the "Servo off" button, the jog operation mode is exited. The related function codes are shown below.

Function code	Name	Setting method	Effective time	Default value	Range	Definition	Unit
P10-01	JOG speed	Operation setting	Effective immediately	100	0 to 3000	JOG speed	rpm

Table 6-2 JOG speed parameter

6.1.4 Rotation direction selection

By setting the "P00-04" rotation direction, you could change the rotation direction of the motor without changing the polarity of the input instruction. The function code is shown in below.

Function code	Name	Setting method	Effective time	Default value	Range	Definition	Unit
P00-04	Rotation direction	Shutdown setting	Effective immediately	0	0 to 1	Forward rotation: Face the motor shaft to watch 0: standard setting (CW is forward rotation) 1: reverse mode (CCW is forward rotation)	-

Table 6-3 Rotation direction parameters

6.1.5 Braking resistor

The servo motor is in the generator state when decelerating or stopping, the motor will transfer energy back to the drive, which will increase the bus voltage. When the bus voltage exceeds the braking point, The drive can consume the feedback energy in the form of thermal energy through the braking resistor. The braking resistor can be built-in or externally connected, but it cannot be used at the same time. When selecting an external braking resistor, it is necessary to remove the short link on the servo drive.

The basis for judging whether the braking resistor is built-in or external.

① the maximum brake energy calculated value > the maximum brake energy absorbed by capacitor, and the brake power calculated value ≤ the built-in braking resistor power, use the built-in braking resistor.

② the maximum brake energy calculated value > the maximum brake energy absorbed by capacitor, and the brake power calculated value > the built-in braking resistor power, use external braking resistor.

Function code	Name	Setting method	Effective time	Default	Range	Definition	Unit
P00-09	Braking resistor setting	Operation setting	Effective immediately	0	0 to 3	0: use built-in braking resistor 1: use external braking resistor and natural cooling 2: use external braking resistor and forced air cooling; (cannot	-

						be set) 3: No braking resistor is used; it is all absorbed by capacitor.	
Note: VD2-010SA1G, VD2F-003SA1P, VD2F-010SA1P and VD2L-010SA1P drives have no built-in resistor by default, so the default value of the function code "P00-09" is 3 (No braking resistor is used, it is all absorbed by capacitor).							
P00-10	External braking resistor value	Operation setting	Effective immediately	50	0 to 65535	It is used to set the external braking resistor value of a certain type of drive.	Ω
P00-11	External braking resistor power	Operation setting	Effective immediately	100	0 to 65535	It is used to set the external braking resistor power of a certain type of drive.	W

Table 6-4 Braking resistor parameters

6.1.6 Servo operation

(1) Set the servo enable (S-ON) to valid (ON)

The servo drive is in a running state and displays "run", but because there is no instruction input at this time, the servo motor does not rotate and is locked.

S-ON can be configured and selected by the DI terminal function selection of the function code "DIDO configuration".

(2) Input the instruction and the motor rotates

Input appropriate instructions during operation, first run the motor at a low speed, and observe the rotation to see if it conforms to the set rotation direction. Observe the actual running speed, bus voltage and other parameters of the motor through the host computer debugging platform.

According to "[7 Adjustment](#)", the motor could work as expected.

(3) Timing diagram of power on

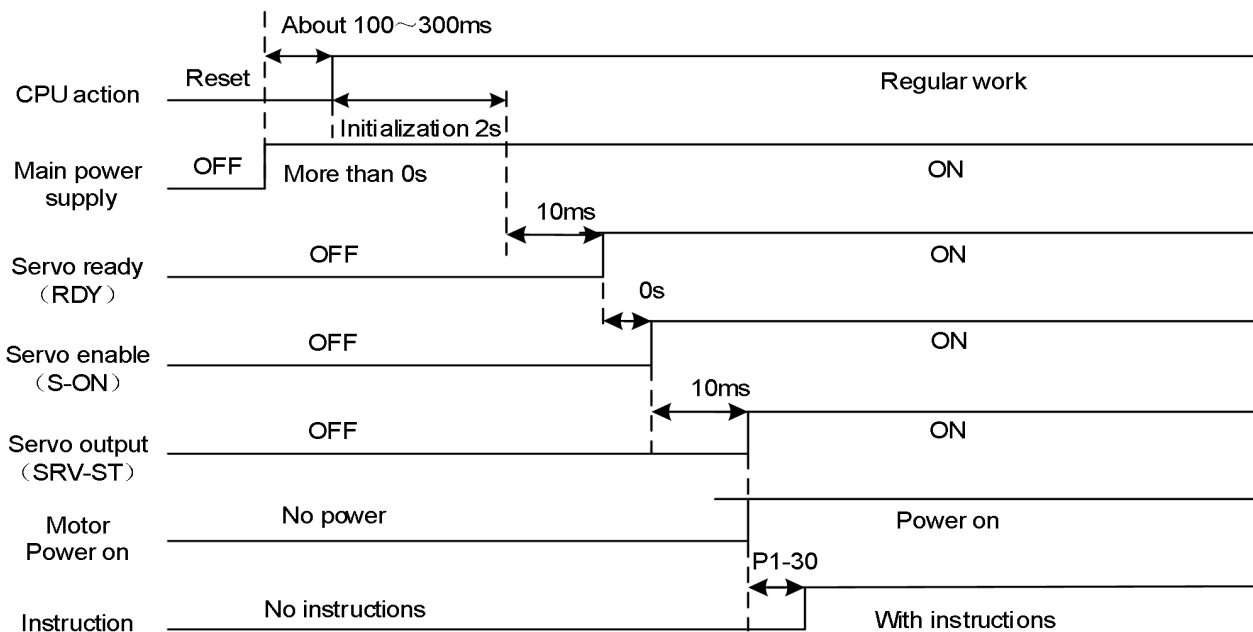

Figure 6-1 Timing diagram of power on

6.1.7 Servo shutdown

According to the different shutdown modes, it could be divided into free shutdown and zero speed shutdown. The respective characteristics are shown in [Table 6-5](#). According to the shutdown status, it could be divided into free running state and position locked, as shown in [Table 6-6](#).

Shutdown mode	Shutdown description	Shutdown characteristics
Free shutdown	Servo motor is not energized and decelerates freely to 0. The deceleration time is affected by factors such as mechanical inertia and mechanical friction.	Smooth deceleration, small mechanical shock, but slow deceleration process.
Zero-speed shutdown	The servo drive outputs reverse braking torque, and the motor quickly decelerates to zero-speed.	Rapid deceleration with mechanical shock, but fast deceleration process.

Table 6-5 Comparison of two shutdown modes

Shutdown status	Free operation status	Position locked
Characteristics	After the motor stops rotating, it is power-off, and the motor shaft can rotate freely.	After the motor stops rotating, the motor shaft is locked and could not rotate freely.

Table 6-6 Comparison of two shutdown status

(1) Servo enable (S-ON) OFF shutdown

The related parameters of the servo OFF shutdown mode are shown in the table below.

Function code	Name	Setting method	Effective time	Default value	Range	Definition	Unit
P00-05	Servo OFF shutdown	Shutdown setting	Effective immediately	0	0 to 1	0: Free shutdown, and the motor shaft remains free status. 1: Zero-speed shutdown, and the motor shaft remains free status.	-

Table 6-7 Servo OFF shutdown mode parameters details

(2) Emergency shutdown

It is free shutdown mode at present, and the motor shaft remains in a free state. The corresponding configuration and selection could be selected through the DI terminal function of the function code "DIDO configuration". The V1.18 firmware version adds the Estop stop time setting function. In some occasions where the servo needs to control the emergency stop of the motor, it is necessary to control the emergency stop time of the DI. Therefore, the P01-05 shutdown deceleration time function is added to deal with this situation.

Estop mode 1 (deceleration stop):

1. Configure DI function code: 8 [ESTOP]
2. Set P1-5 shutdown deceleration time.
3. Trigger DI emergency shutdown.
4. Servo emergency shutdown and deceleration to zero speed.

Estop mode 2:

1. Configure DI function code: 1 [Servo enable SON]
2. Set P1-05 shutdown deceleration time.
3. Set P0-05 Servo OFF shutdown mode: zero speed stop.
4. Trigger DI to turn off servo enable SON.

5. Servo enable turns off and stops and decelerates to zero speed.

Function code	Name	Setting method	Effective time	Default	Range	Definition	Unit
P01-05	Shutdown deceleration time	Shutdown setting	immediately Effective	50	0 to 65535	The time for the speed command to decelerate from 1000rpm to 0	ms

(3) Overtravel shutdown

Overtravel means that the movable part of the machine exceeds the set area. In some occasions where the servo moves horizontally or vertically, it is necessary to limit the movement range of the workpiece. The overtravel is generally detected by limit switches, photoelectric switches or the multi-turn position of the encoder, that is, hardware overtravel or software overtravel.

Once the servo drive detects the action of the limit switch signal, it will immediately force the speed in the current direction of rotation to 0 to prevent it from continuing, and it will not be affected for reverse rotation. The overtravel shutdown is fixed at zero speed and the motor shaft remains locked.

The corresponding configuration and selection could be selected through the DI terminal function of the function code "DIDO configuration". The default function of DI3 is POT and DI4 is NOT, as shown in the table below.

Function code	Name	Setting method	Effective time	Default value	Range	Definition	Unit
P06-08	DI_3 channel function selection	Operation setting	Power-on again	3	0 to 32	0: OFF (not used) 01: S-ON servo enable 02: A-CLR fault and Warning Clear 03: POT forward drive prohibition 04: NOT Reverse drive prohibition 05: ZCLAMP Zero speed 06: CL Clear deviation counter 07: C-SIGN Inverted instruction 08: E-STOP Emergency stop 09: GEAR-SEL Electronic Gear Switch 1 10: GAIN-SEL gain switch 11: INH Instruction pulse prohibited input 12: VSSEL Vibration control switch input 13: INSPD1 Internal speed instruction selection 1 14: INSPD2 Internal speed instruction selection 2 15: INSPD3 Internal speed instruction selection 3 16: J-SEL inertia ratio switch (not implemented yet) 17: MixModesel mixed mode selection 20: Internal multi-segment position enable signal 21: Internal multi-segment position selection 1 22: Internal multi-segment position selection 2 23: Internal multi-segment position selection 3 24: Internal multi-segment position selection 4 Others: reserved	-
P06-09	DI_3 channel logic selection	Operation setting	Effective immediately	0	0 to 1	DI port input logic validity function selection. 0: Normally open input. Active low level (switch on); 1: Normally closed input. Active high level (switch off);	-
P06-10	DI_3 input source selection	Operation setting	Effective immediately	0	0 to 1	Select the DI_3 port type to enable 0: Hardware DI_3 input terminal 1: virtual VDI_3 input terminal	-

P06-11	DI_4 channel function selection	Operation setting	again Power-on	4	0 to 32	0 off (not used) 01: SON Servo enable 02: A-CLR Fault and Warning Clear 03: POT Forward drive prohibition 04: NOT Reverse drive prohibition 05: ZCLAMP Zero speed 06: CL Clear deviation counter 07: C-SIGN Inverted instruction 08: E-STOP Emergency shutdown 09: GEAR-SEL Electronic Gear Switch 1 10: GAIN-SEL gain switch 11: INH Instruction pulse prohibited input 12: VSSEL Vibration control switch input 13: INSPD1 Internal speed instruction selection 1 14: INSPD2 Internal speed instruction selection 2 15: INSPD3 Internal speed instruction selection 3 16: J-SEL inertia ratio switch (not implemented yet) 17: MixModesel mixed mode selection 20: Internal multi-segment position enable signal 21: Internal multi-segment position selection 1 22: Internal multi-segment position selection 2 23: Internal multi-segment position selection 3 24: Internal multi-segment position selection 4 Others: reserved	-
P06-12	DI_4 channel logic selection	Operation setting	Effective immediately	0	0 to 1	DI port input logic validity function selection. 0: Normally open input. Active low level (switch on); 1: Normally closed input. Active high level (switch off);	-
P06-13	DI_4 input source selection	Operation setting	Effective immediately	0	0 to 1	Select the DI_4 port type to enable 0: Hardware DI_4 input terminal 1: virtual VDI_4 input terminal	-

Table 6-8 DI3 and DI4 channel parameters

(4) Malfunction shutdown

When the machine fails, the servo will perform a fault shutdown operation. The current shutdown mode is fixed to the free shutdown mode, and the motor shaft remains in a free state.

6.1.8 Brake device

The brake is a mechanism that prevents the servo motor shaft from moving when the servo drive is in a non-operating state, and keeps the motor locked in position, so that the moving part of the machine will not move due to its own weight or external force.

CAUTION

- The brake device is built into the servo motor, which is only used as a non-energized fixed special mechanism. It cannot be used for braking purposes, and can only be used when the servo motor is kept stopped;
- After the servo motor stops, turn off the servo enable (S-ON) in time;
- The brake coil has no polarity;
- When the brake coil is energized (that is, the brake is open), magnetic flux leakage may occur at the shaft end and other parts. If users need to use magnetic sensors and other device near the motor, please pay attention!
- When the motor with built-in brake is in operation, the brake device may make a clicking sound, which does not affect the function.

(1) Wiring of brake device

The brake input signal has no polarity. You need to prepare a 24V power supply. The standard connection of brake signal BK and brake power supply is shown in the figure below. (take VD2B servo drive as example)

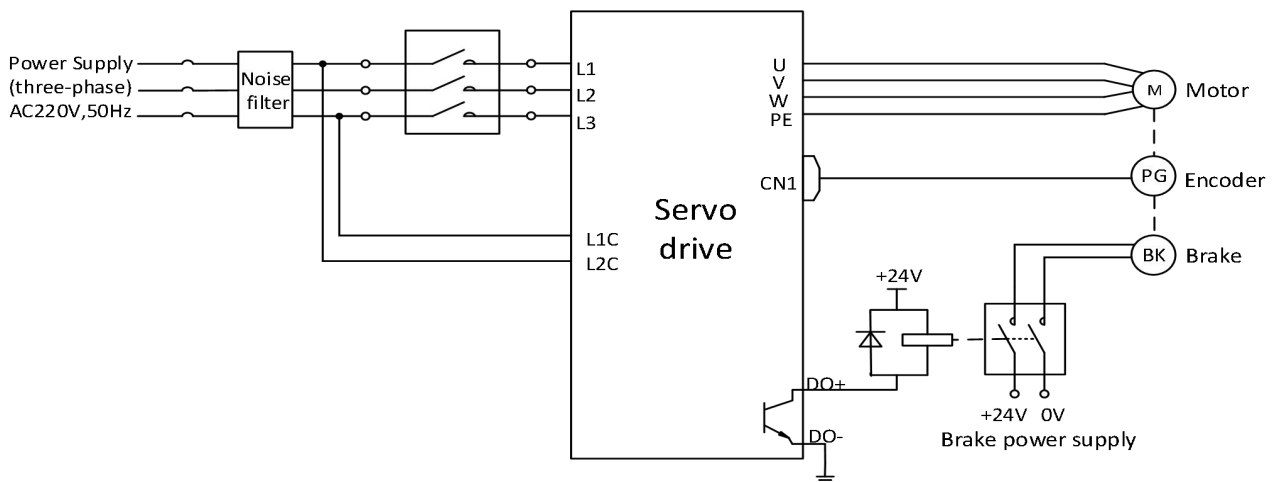

Figure 6-2 VD2B servo drive brake wiring

CAUTION

- The length of the motor brake cable needs to fully consider the voltage drop caused by the cable resistance, and the brake operation needs to ensure that the voltage input is 24V.
- It is recommended to use the power supply alone for the brake device. If the power supply is shared with other electrical device, the voltage or current may decrease due to the operation of other electrical device, which may cause the brake to malfunction.
- It is recommended to use cables above 0.5 mm².

(2) Brake software setting

For a servo motor with brake, one DO terminal of servo drive must be configured as function 141 (BRK-OFF, brake output), and the effective logic of the DO terminal must be determined. Related function code is as below.

DO function code	Function name	Function	Effective time
141	BRK-OFF Brake output	Output the signal indicates the servo motor brake release	Power-on again

Table 6-10 Relevant function codes for brake setting

Function code	Name	Setting method	Effective time	Default value	Range	Definition	Unit
P1-30	Delay from brake output to instruction reception	Operation setting	Effective immediately	250	0 to 500	Set delay that from the brake (BRK-OFF) output is ON to servo drive allows to receive input instruction. When brake output (BRK-OFF) is not allocated, the function code has no effect.	ms
P1-31	In static state, delay from brake output OFF to the motor is power off	Operation setting	Effective immediately	150	1 to 1000	When the motor is in a static state, set the delay time from brake (BRK-OFF) output OFF to servo drive enters the non-channel state. When the brake output (BRK-OFF) is not allocated, this function code has no effect.	ms
P1-32	Rotation status, when the brake output OFF, the speed threshold	Operation setting	Effective immediately	30	0 to 3000	When the motor rotates, the motor speed threshold when the brake (BRK-OFF) is allowed to output OFF. When the brake output (BRK-OFF) is not allocated, this function code has no effect.	rpm
P1-33	Rotation status, Delay from servo enable OFF to brake output OFF	Operation setting	Effective immediately	500	1 to 1000	When the motor rotates, the delay time from the servo enable (S-ON) OFF to the brake (BRK-OFF) output OFF is allowed. When brake output (BRK-OFF) is not allocated, this function code has no effect.	ms

According to the state of servo drive, the working sequence of the brake mechanism can be divided into the brake sequence in the normal state of the servo drive and the brake sequence in the fault state of the servo drive.

(3) Servo drive brake timing in normal state

The brake timing of the normal state could be divided into: servo motor static (the actual speed of motor is lower than 20 rpm) and servo motor rotation (the actual speed of the motor reaches 20 and above).

1) Brake timing when servo motor is stationary

When the servo enables changes from ON to OFF, if the actual motor speed is lower than 20 rpm, the servo drive will act according to the static brake sequence. The specific sequence action is shown in [Figure 6-3](#)

! CAUTION

- ☞ After the brake output is from OFF to ON, within P01-30, do not input position/speed/torque instructions, otherwise the instructions will be lost or operation errors will be caused.
- ☞ When applied to a vertical axis, the external force or the weight of the mechanical moving part may cause the machine to move slightly. When the servo motor is stationary, and the servo enable is OFF, the brake output will be OFF immediately. However, the motor is still energized within the time of P01-31 to prevent mechanical movement from moving due to its own weight or external force.

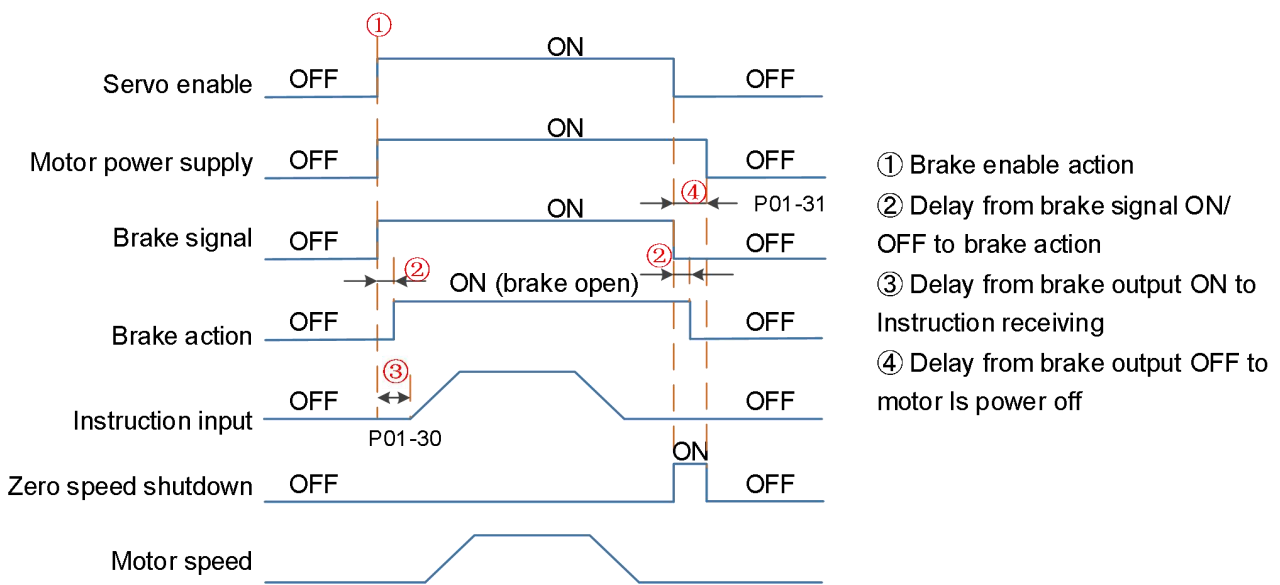

Figure 6-3 Brake Timing of when the motor is stationary

Note: For the delay time of the contact part of the brake at ② in the figure, please refer to the relevant specifications of motor.

2) The brake timing when servo motor rotates

When the servo enable is from ON to OFF, if the actual motor speed is greater than or equal to 20 rpm, the drive will act in accordance with the rotation brake sequence. The specific sequence action is shown in [Figure 6-4](#).

! CAUTION

- ☞ When the servo enable is turned from OFF to ON, within P1-30, do not input position, speed or torque instructions, otherwise the instructions will be lost or operation errors will be caused.
- ☞ When the servo motor rotates, the servo enable is OFF and the servo motor is in the zero-speed shutdown state, but the brake output must meet any of the following conditions before it could be set OFF:
 P01-33 time has not arrived, but the motor has decelerated to the speed set by P01-32;
 P01-33 time is up, but the motor speed is still higher than the set value of P01-32.
- ☞ After the brake output changes from ON to OFF, the motor is still in communication within 50ms to prevent the mechanical movement from moving due to its own weight or external force.

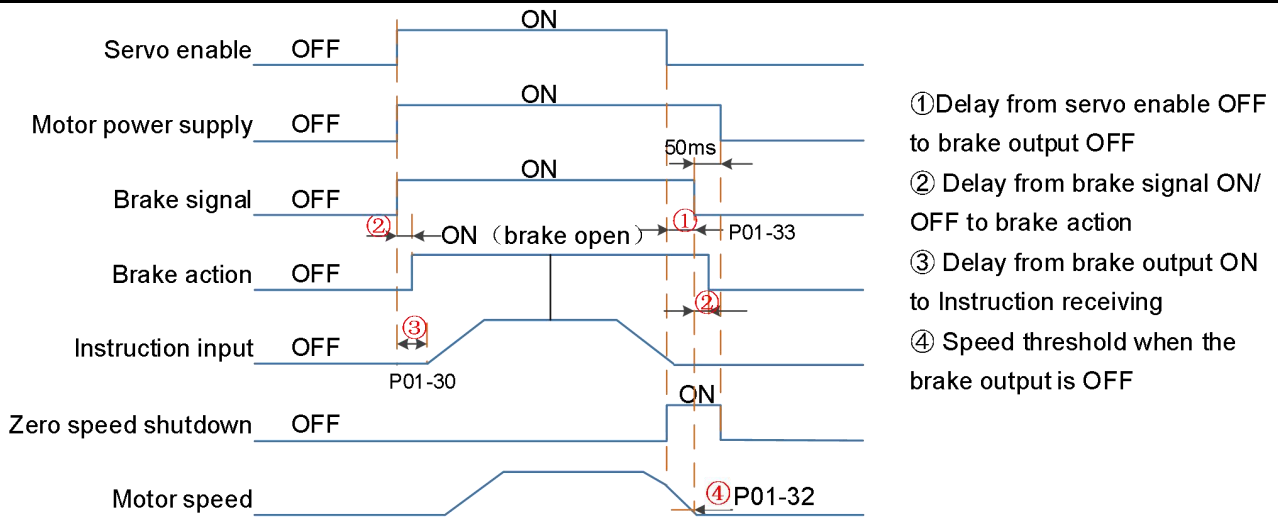

Figure 6-4 Brake timing when the motor rotates

(4) Brake timing when the servo drive fails

The brake timing (free shutdown) in the fault status is as follows.

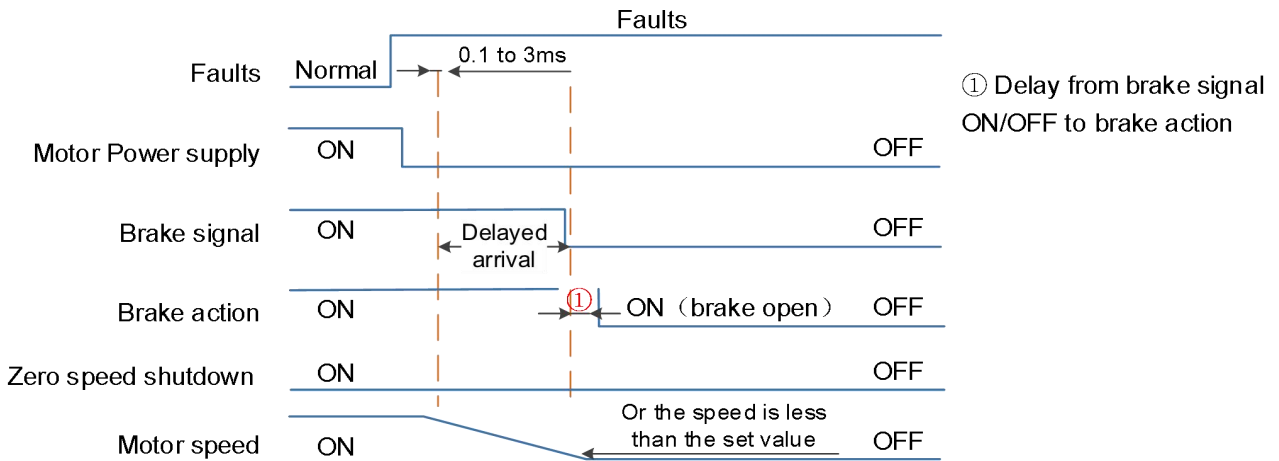

Figure 6-5 The brake timing (free shutdown) in the fault state

Note: The "delay arrival" of the brake signal is about 20ms, and the actual parameter is subject to the motor manufacturer

6.2 Position control mode

Position control is the most important and commonly used control mode of the servo system. Position control refers to controlling the position of the motor through position instructions, and determining the target position of the motor by the total number of position instructions. The frequency of the position instruction determines the motor rotation speed. The servo drive can achieve fast and accurate control of the position and speed of the machine. Therefore, the position control mode is mainly used for occasions that require positioning control, such as manipulators, moulder, engraving machines, CNC machine tools, etc. The position control block diagram is shown in the figure below.

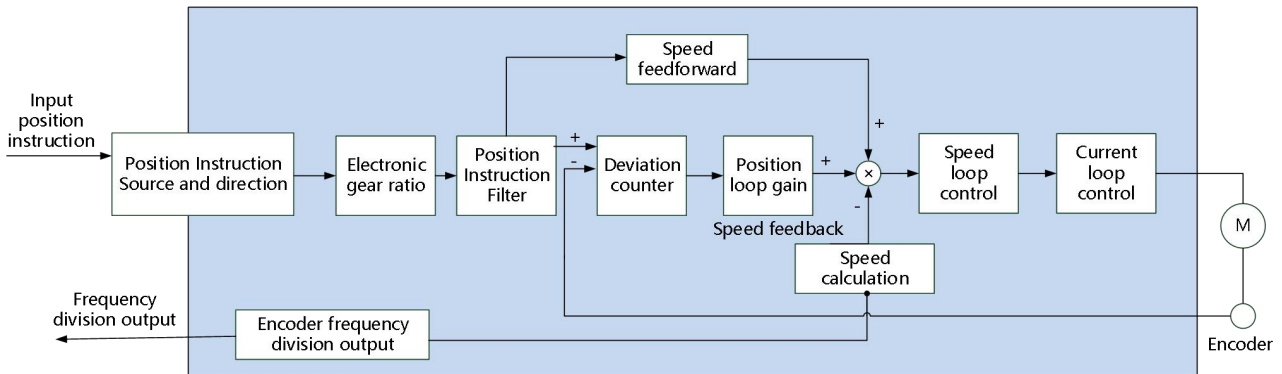

Figure 6-6 Position control diagram

Set “P00-01” to 1 by the software “Wecon SCTool”, and the servo drive is in position control mode.

Function code	Name	Setting method	Effective time	Default value	Range	Definition	Unit
P00-01	Control mode	Shutdown setting	Immediately effective	1	1 to 6	1: Position control 2: Speed control 3: Torque control 4: Position/speed mix control 5: Position/torque mix control 6: Speed /torque mix control Note: VD2L drive P0-01 setting range: 1-3. Mixed mode is not supported for the time being!	-

Table 6-11 Control mode parameters

6.2.1 Position instruction input setting

When the VD2 series servo drive is in position control mode, firstly set the position instruction source through the function code “P01-06”.

Function code	Name	Setting method	Effective time	Default value	Range	Definition	Unit
P01-06	Position instruction source	Operation setting	immediately Effective	0	0 to 1	0: Pulse instruction 1: Internal position instruction	-

Table 6-12 Position instruction source parameter

(1) The source of position instruction is pulse instruction (P01-06=0)

1) Low-speed pulse instruction input

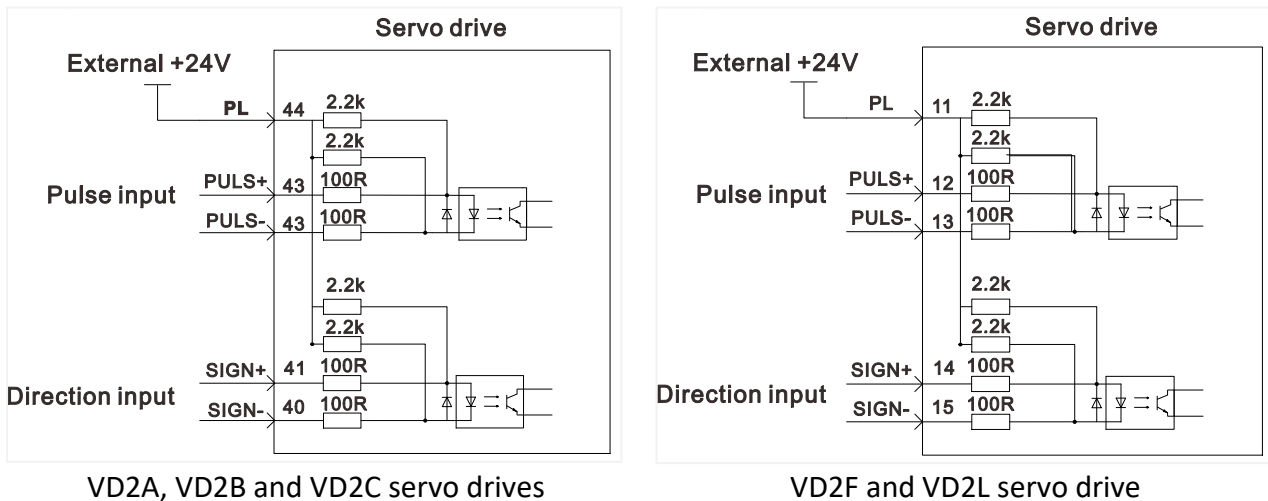

Figure 6-7 Position instruction input setting

VD2 series servo drive has a set of pulse input terminals to receive the input of position pulse (via the CN2 terminal). The position pulse mode connection is shown in [Figure 6-7](#). The instruction pulse and symbol output circuit on the control device (HMI/PLC) side could select differential input or open collector input. The maximum input frequency is shown as below.

Pulse method	Maximum frequency	Voltage
Open collector input	200K	24V
Differential input	500K	5V

Table 6-13 Pulse input specifications

① Differential input

Take VD2A, VD2B and VD2C drive as examples, the connection of differential input is shown as below.

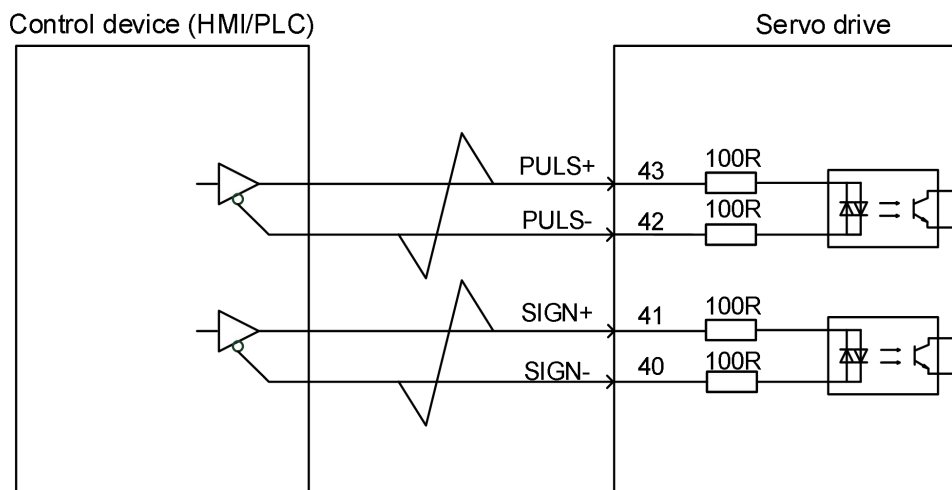

Figure 6-8 Differential input connection

Note: The differential input connection of the VD2F drive differs only from the signal pin number. Please refer to [“4.4.3 position instruction input signal”](#)

② Open collector input

Take VD2A, VD2B and VD2C drive as examples, the connection of differential input is shown as below.

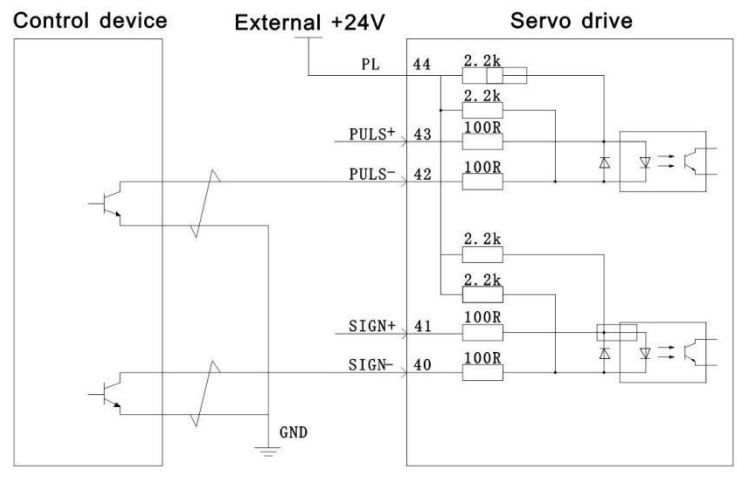

Figure 6-9 Open collector input connection

Note:

The differential input connection of the VD2F and VD2L drive differs only from the signal pin number. Please refer to [“4.4.3 position instruction input signal”](#)

2) Position pulse frequency and anti-interference level

When low-speed pulses input pins, you need to set a certain pin filter time to filter the input pulse instructions to prevent external interference from entering the servo drive and affecting motor control. After the filter function is enabled, the input and output waveforms of the signal are shown as below.

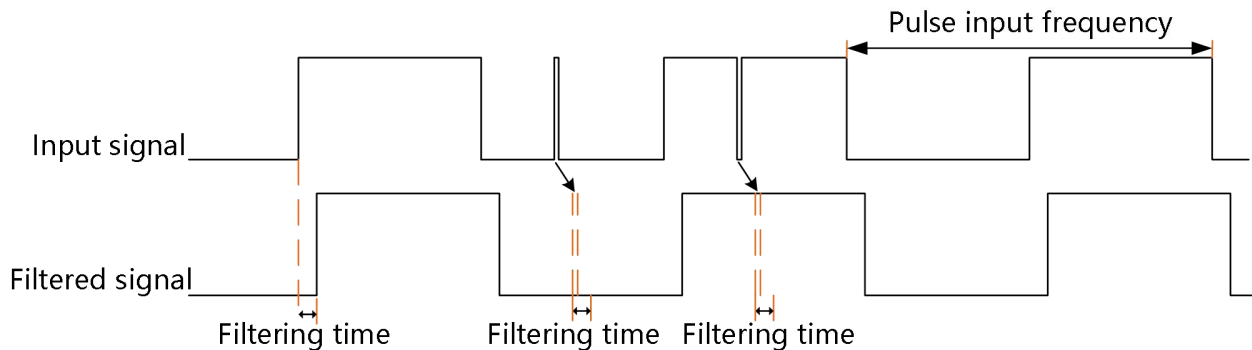

Figure 6-10 Example of filtered signal waveform

The input pulse frequency refers to the frequency of the input signal, which can be modified through the function code “P00-13”. If the actual input frequency is greater than the set value of “P00-13”, it may cause pulse loss or alarm. The position pulse anti-interference level can be adjusted through the function code “P00-14”, the larger the set value, the greater the filtering depth. The details of related function code parameters are as shown below.

Function code	Name	Setting method	Effective time	Default value	Range	Definition	Unit
---------------	------	----------------	----------------	---------------	-------	------------	------

P00-14	Position pulse anti-interference level	Operation setting	Power-on again	2	0 to 9	Set the anti-interference level of external pulse instruction. 0: no filtering; 1: Filtering time 128ns 2: Filtering time 256ns 3: Filtering time 512ns 4: Filtering time 1.024us 5: Filtering time 2.048us 6: Filtering time 4.096us 7: Filtering time 8.192us 8: Filtering time 16.384us	-	
						9		VD2: Filtering time 32.768us
								VD2F: Filtering time 25.5us

Table 6-14 Position pulse frequency and anti-interference level parameters

Function code	Name	Setting method	Effective time	Default value	Range	Definition	Unit
P00-14	Position pulse anti-interference level	Operation setting	Power-on again	2	0 to 8	VD2L drive set the anti-interference level of external pulse instruction. 0: no filtering; 1: Filtering time 111.1ns 2: Filtering time 222.2ns 3: Filtering time 444.4ns 4: Filtering time 888.8ns 5: Filtering time 1777.7ns 6: Filtering time 3555.5ns 7: Filtering time 7111.7ns 8: Filtering time 14222.2ns	-

Table 6-15 VD2L Position pulse frequency and anti-interference level parameters

3) Position pulse type selection

In VD2 series servo drives, there are three types of input pulse instructions, and the related function codes are shown in the table below.

Function code	Name	Setting method	Effective time	Default value	Range	Definition	Unit
P00-12	Position pulse type selection	Operation setting	Power-on again	0	0 to 5	0: Direction + pulse (positive logic) 1: CW/CCW 2: A, B phase quadrature pulse (4 times frequency) 3: Direction + pulse (negative logic) 4: CW/CCW (negative logic) 5: A, B phase quadrature pulse (4 times frequency negative logic) Note: VD2F and VD2L series drivers do not support the pulse form of CW/CCW! P0-12 parameter setting range of VD2L: 0, 2, 3, 5	-

Table 6-16 Position pulse type selection parameter

Pulse type selection	Pulse type	Signal	Schematic diagram of forward pulse	Schematic diagram of negative pulse
0	Direction + pulse (Positive logic)	PULSE SIGN		
1	CW/CCW	PULSE (CW) SIGN (CCW)		
2	AB phase orthogonal pulse (4 times frequency)	PULSE (Phase A) SIGN (Phase B)		
3	Direction + pulse (Negative logic)	PULSE SIGN		
4	CW/CCW (Negative logic)	PULSE (CW) SIGN (CCW)		
5	AB phase orthogonal pulse (4 times frequency negative logic)	PULSE (Phase A) SIGN (Phase B)		

Table 6-17 Pulse description

(2) The source of position instruction is internal position instruction (P01-06=1)

The VD2 series servo drive has a multi-segment position operation function, which supports maximum 16-segment instructions. The displacement, maximum operating speed (steady-state operating speed) and acceleration/deceleration time of each segment could be set separately. The waiting time between positions could also be set according to actual needs. The setting process of multi-segment position is shown in [Figure 6-11](#).

The servo drive completely runs the multi-segment position instruction set by P07-01 once, and the total number of positions is called completing one round of operation.

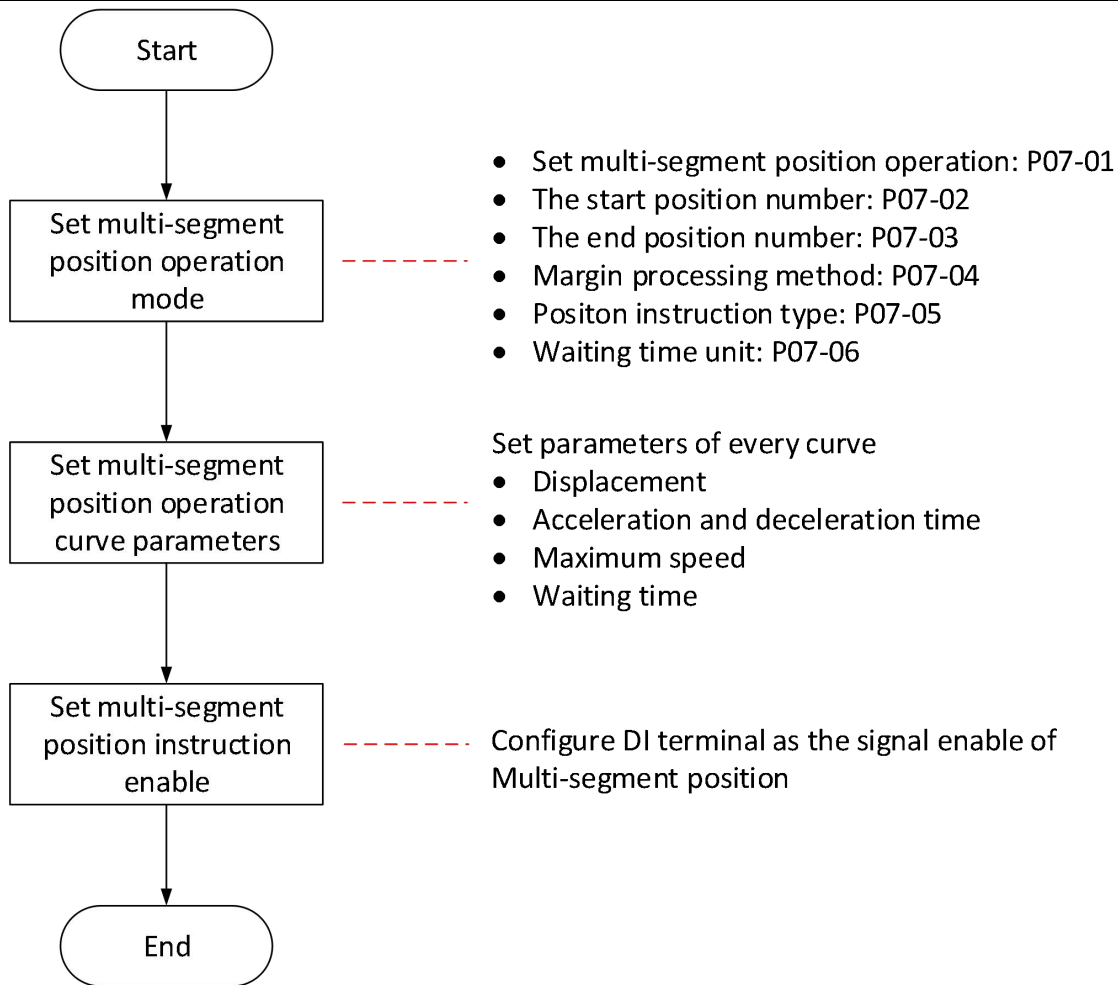

Figure 6-11 The setting process of multi-segment position

1) Set multi-segment position running mode

Function code	Name	Setting method	Effective time	Default value	Range	Definition	Unit
P07-01	Multi-segment position running mode	Shutdown setting	Effective immediately	0	0 to 2	0: Single running 1: Cycle running 2: DI switching running	-
P07-02	Start segment number	Shutdown setting	Effective immediately	1	1 to 16	1st segment NO. in non-DI switching mode	-
P07-03	End segment number	Shutdown setting	Effective immediately	1	1 to 16	last segment NO. in non-DI switching mode	-
P07-04	Margin processing method	Shutdown setting	Effective immediately	0	0 to 1	0: Run the remaining segments 1: Run again from the start segment	-
P07-05	Displacement instruction type	Shutdown setting	Effective immediately	0	0 to 1	0: Relative position instruction 1: Absolute position instruction	-

Table 6-18 multi-segment position running mode parameters

VD2 series servo drive has three multi-segment position running modes, and you could select the best running mode according to the site requirements.

① Single run

In this running mode, the segment number is automatically incremented and switched, and the servo drive only operates for one round (the servo drive runs completely once for the total number of multi-segment position instructions set by P07-02 and P07-03). The single run curve is shown in [Figure 6-12](#), and S_1 and S_2 are the displacements of the 1st segment and the 2nd segment respectively

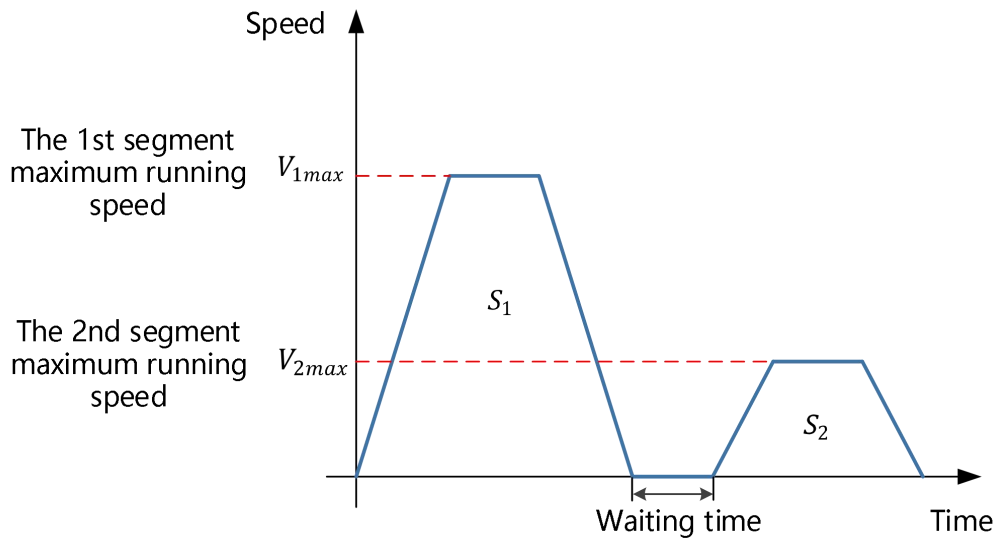

Figure 6-12 Single run curve (P07-02=1, P07-03=2)

② Cycle running

In this running mode, the position number is automatically incremented and switched, and the servo drive repeatedly runs the total number of multi-segment position instructions set by P07-02 and P07-03. The waiting time could be set between each segment. The cycle running curve is shown in [Figure 6-13](#), and S_1, S_2, S_3 and S_4 are the displacements of the 1st, 2nd, 3rd and 4th segment respectively.

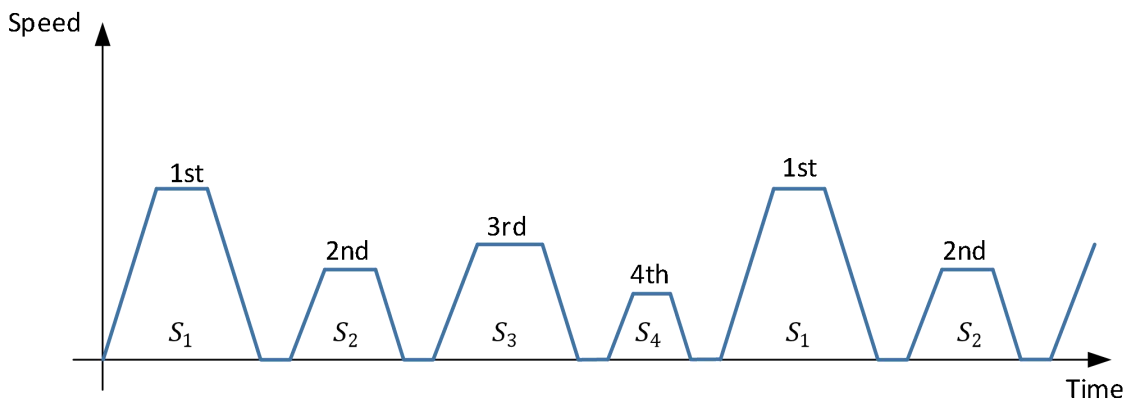

Figure 6-13 Cycle running curve (P07-02=1, P07-03=4)

CAUTION

In single running and cycle running mode, the setting value of P07-03 needs to be greater than the setting value of P07-02.

③ DI switching running

In this running mode, the next running segment number could be set when operating the current segment number. The interval time is determined by the instruction delay of the host computer. The

running segment number is determined by DI terminal logic, and the related function codes are shown in the table below.

DI function code	Function name	Function
21	INPOS1: Internal multi-segment position segment selection 1	Form internal multi-segment position running segment number
22	INPOS2: Internal multi-segment position segment selection 2	Form internal multi-segment position running segment number
23	INPOS3: Internal multi-segment position segment selection 3	Form internal multi-segment position running segment number
24	INPOS4: Internal multi-segment position segment selection 4	Form internal multi-segment position running segment number

Table 6-19 DI function code

The multi-segment segment number is a 4-bit binary number, and the DI terminal logic is level valid. When the input level is valid, the segment selection bit value is 1, otherwise it is 0. Figure 6-17 shows the correspondence between the position bits 1 to 4 of the internal multi-segment position and the position number.

INPOS4	INPOS3	INPOS2	INPOS1	Running position number
0	0	0	0	1
0	0	0	1	2
0	0	1	0	3
.....				
1	1	1	1	16

Table 6-20 INPOS corresponds to running segment number

The operating curve in this running mode is shown in [Figure 6-14](#).

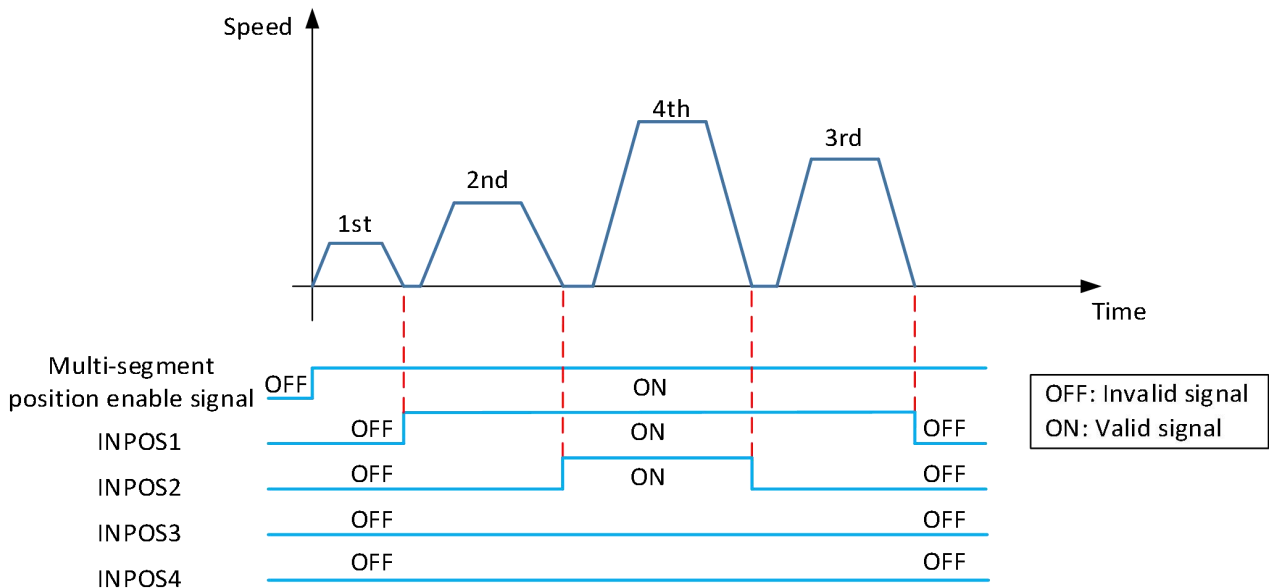

Note: INPOS is internal multi-segment position segment selection

Figure 6-14 DI switching running curve

VD2 series servo drives have two margin processing methods: run the remaining segments and run from the start segment again. The related function code is P07-04.

A. Run the remaining segments

In this processing way, the multi-segment position instruction enable is OFF during running, the servo drive will abandon the unfinished displacement part and shutdown, and the positioning completion signal will be valid after the shutdown is complete. When the multi-segment position enable is ON, and the servo drive will start to run from the next segment where the OFF occurs. The curves of single running and cycle running are shown in [Figure 6-15](#) and [Figure 6-16](#) respectively.

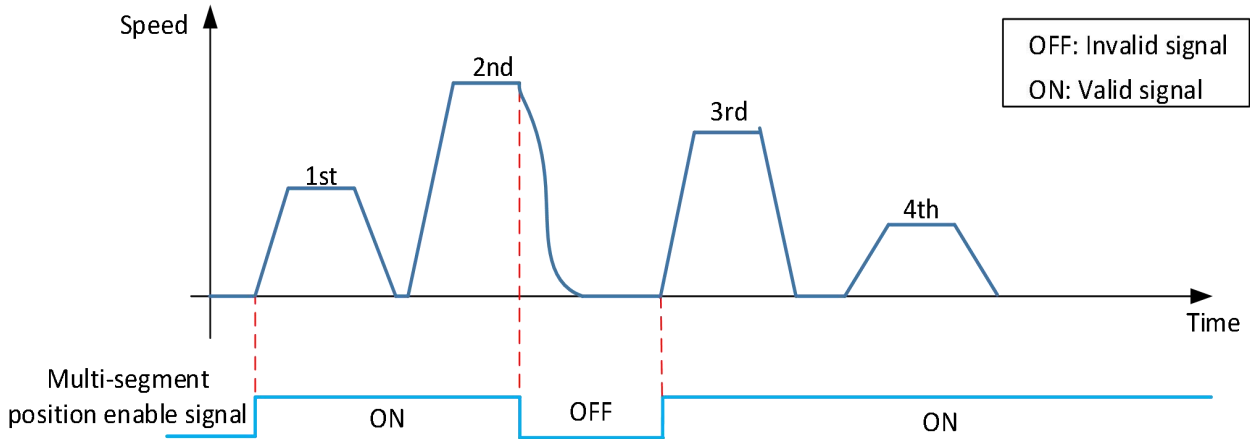

Figure 6-15 Single running-run the remaining segments (P07-02=1, P07-03=4)

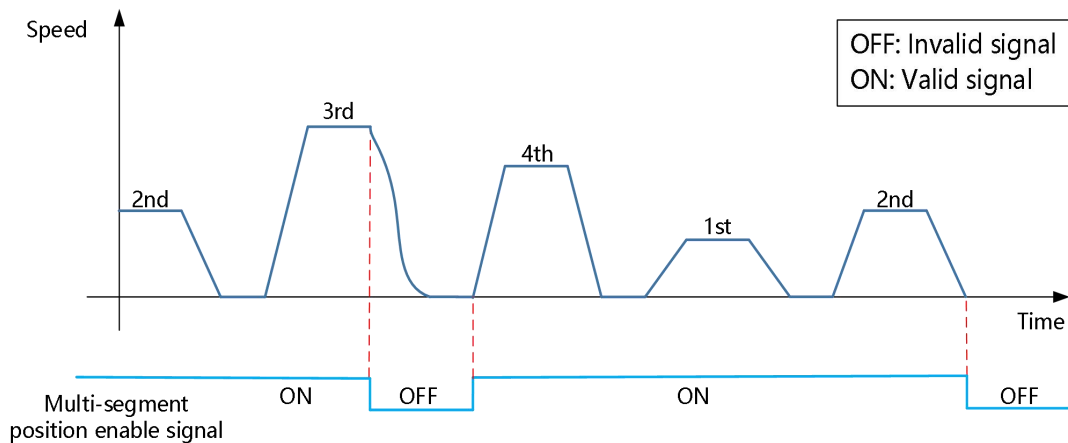

Figure 6-16 Cycle running-run the remaining segment (P07-02=1, P07-03=4)

B. Run again from the start segment

In this processing mode, when the multi-segment position instruction enable is OFF during running, the servo drive will abandon the uncompleted displacement part and shutdown. After the shutdown is completed, the positioning completion signal is valid. When the multi-segment position enable is ON, and the servo drive will start to operate from the next position set by P07-02. The curves of single running and cycle running are shown in [Figure 6-17](#) and [Figure 6-18](#) respectively.

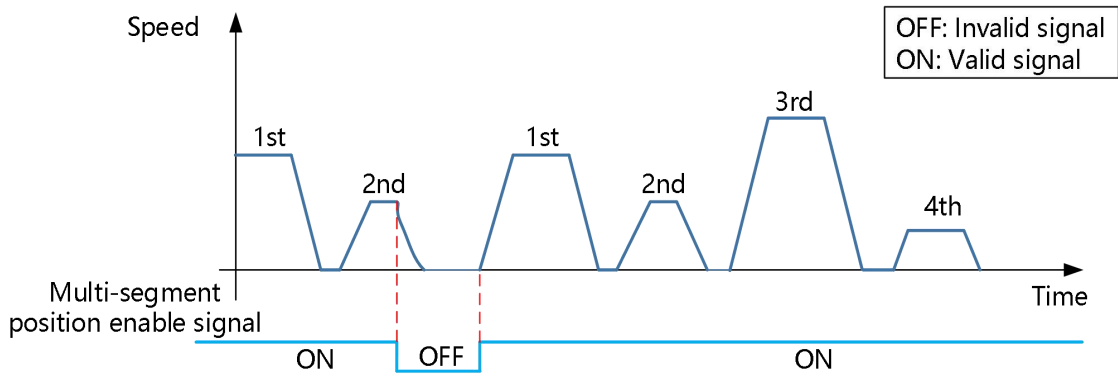

Figure 6-17 Single running-run from the start segment again (P07-02=1, P07-03=4)

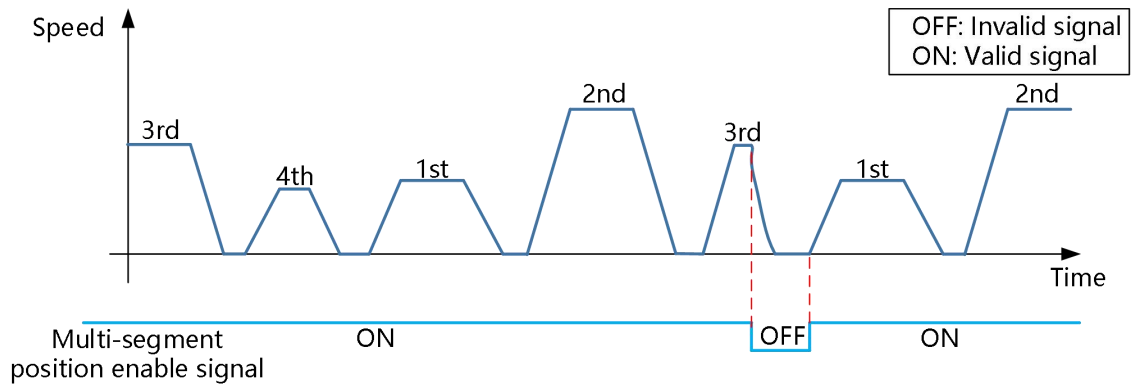

Figure 6-18 Cyclic running-run from the start segment again (P07-02=1, P07-03=4)

VD2 series servo drives have two types of displacement instructions: relative position instruction and absolute position instruction. The related function code is P07-05.

A. Relative position instruction

The relative position instruction takes the current stop position of the motor as the start point and specifies the amount of displacement.

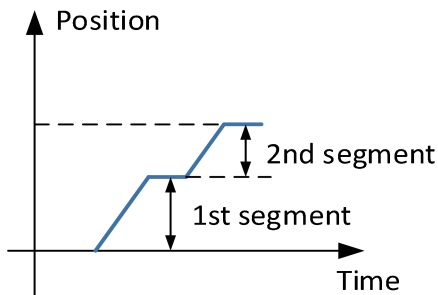

Figure 6-19 Relative position diagram

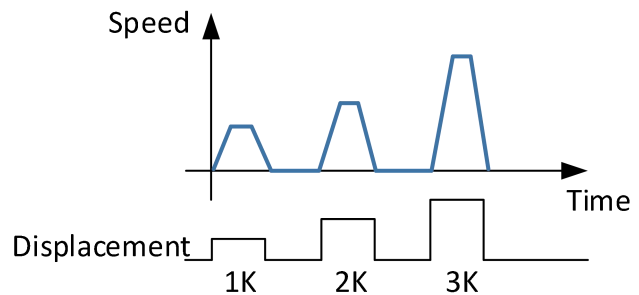

Figure 6-20 Displacement diagram

B. Absolute position instruction

The absolute position instruction takes "reference origin" as the zero point of absolute positioning, and specifies the amount of displacement.

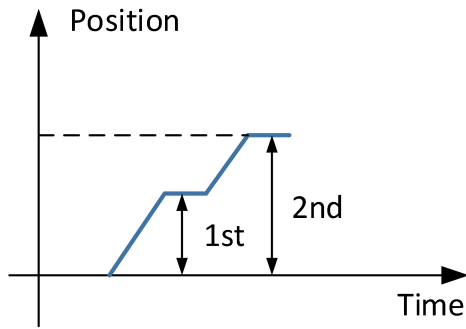

Figure 6-21 Absolute indication

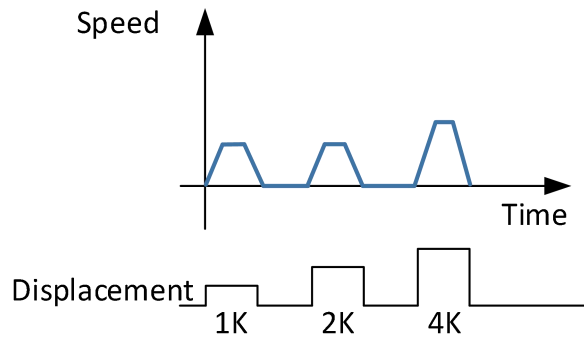

Figure 6-22 Displacement

2) Multi-segment position running curve setting

The multi-segment position running supports maximum 16 segments different position instructions. The displacement, maximum running speed (steady-state running speed), acceleration and deceleration time of each position and the waiting time between segment could all be set. [Table 6-19](#) are the related function codes of the 1st segment running curve.

Function code	Name	Setting method	Effective time	Default value	Range	Definition	Unit
P07-09	1st segment displacement	Operation setting	Effective immediately	10000	-2147483 647 to 21474836 46	Position instruction, positive and negative values could be set	-
P07-10	Maximum speed of the 1st displacement	Operation setting	Effective immediately	100	1 to 5000	Steady-state running speed of the 1st segment	rpm
P07-11	Acceleration and deceleration of 1st segment displacement	Operation setting	Effective immediately	100	1 to 65535	The time required for the acceleration and deceleration of the 1st segment	ms
P07-12	Waiting time after completion of the 1st segment displacement	Operation setting	Effective immediately	100	1 to 65535	Delayed waiting time from the completion of the 1st segment to the start of the next segment	Set by P07-06

Table 6-21 The 1st position operation curve parameters table

After setting the above parameters, the actual operation curve of the motor is shown in Figure 6-23

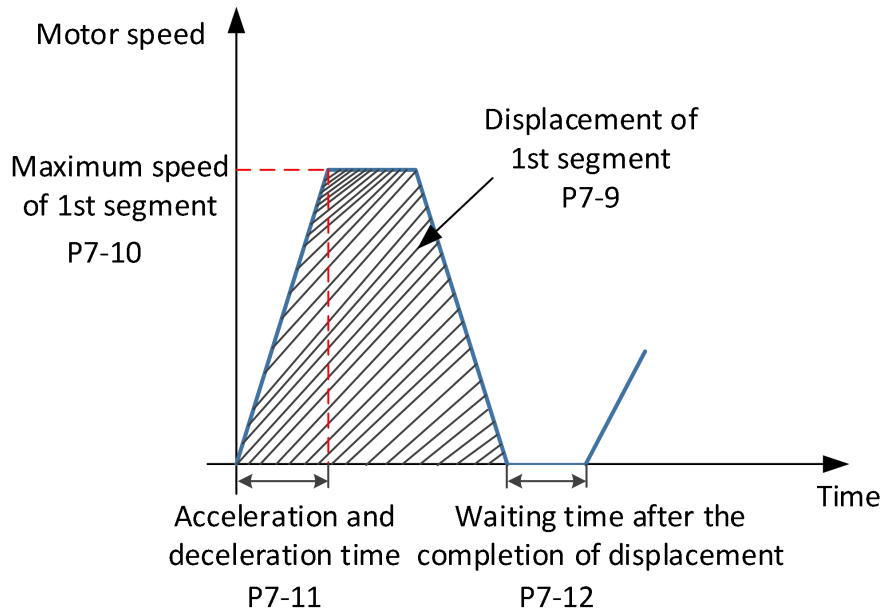

Figure 6-23 The 1st segment running curve of motor

3) multi-segment position instruction enables

When selecting multi-segment position instruction as the instruction source, configure 1 DI port channel of the servo drive to function 20 (internal multi-segment position enable signal), and confirm the valid logic of the DI terminal.

DI function code	Function name	Function
20	ENINPOS: Internal multi-segment position enable signal	DI port logic invalid: Does not affect the current operation of the servo motor. DI port logic valid: Motor runs multi-segment position

! CAUTION

It should be noted that only when the internal multi-segment position enable signal is OFF, can the P07 group parameters be actually modified to write into the servo drive!

6.2.2 Electronic gear ratio

(1) Definition of electronic gear ratio

In the position control mode, the input position instruction (instruction unit) is to set the load displacement, and the motor position instruction (encoder unit) is to set the motor displacement, in order to establish the proportional relationship between the motor position instruction and the input position instruction, electronic gear ratio function is used. "Instruction unit" refers to the minimum resolvable value input from the control device (HMI/PLC) to the servo drive. "Encoder unit" refers to the value of the input instruction processed by the electronic gear ratio.

With the function of the frequency division (electronic gear ratio < 1) or multiplication (electronic gear ratio > 1) of the electronic gear ratio, the actual the motor rotation or movement displacement can be set when the input position instruction is 1 instruction unit.

It is noted that the electronic gear ratio setting range of the 2500-line incremental encoder should meet the formula (6-1), and the electronic gear ratio setting range of the 17-bit encoder should

meet the formula (6-2), setting range of the electronic gear ratio of 23-bit encoder should meet the formula (6-3)

$$0.01 < \frac{\text{Electronic gear ratio numerator}}{\text{Electronic gear ratio denominator}} < 100 \quad (6-1)$$

$$0.001 < \frac{\text{Electronic gear ratio numerator}}{\text{Electronic gear ratio denominator}} < 500 \quad (6-2)$$

$$0.001 < \frac{\text{Electronic gear ratio numerator}}{\text{Electronic gear ratio denominator}} < 32000 \quad (6-3)$$

Otherwise, the servo drive will report Er.35: "Electronic gear ratio setting exceeds the limit"!

(2) Setting steps of electronic gear ratio

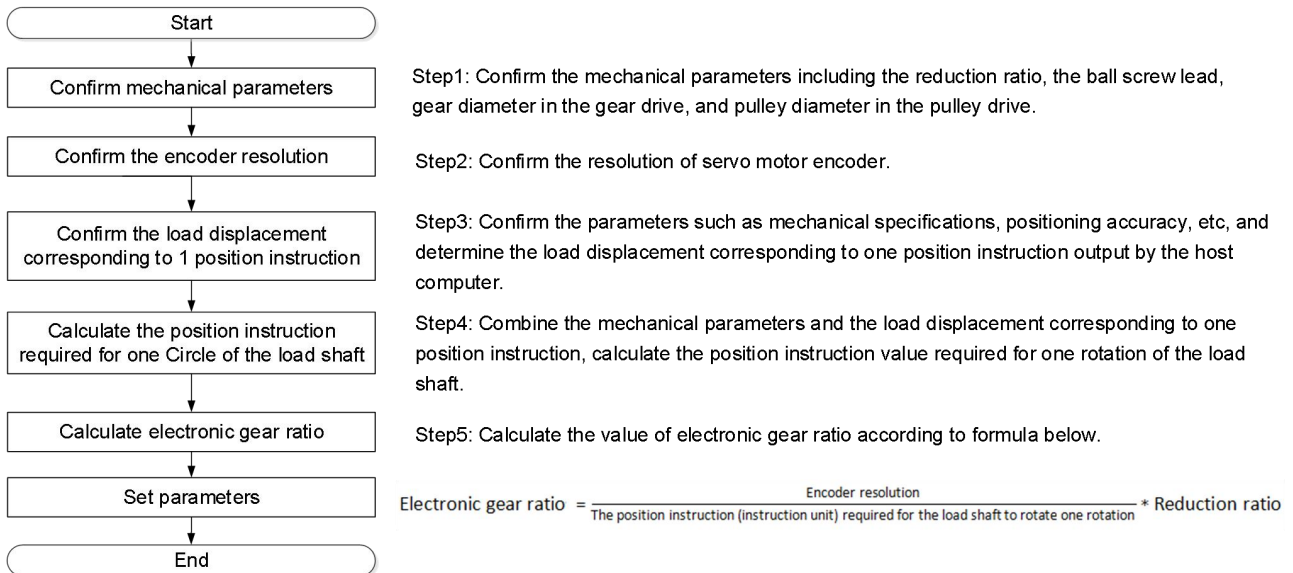

Figure 6-24 Setting steps of electronic gear ratio

(3) Electronic gear ratio switch setting

When the function code P00-16 is 0, the electronic gear ratio switching function could be used. You could switch between electronic gear 1 and electronic gear 2 as needed. There is only one set of gear ratios at any time. Related function codes are shown in the table below.

Function code	Name	Setting method	Effective time	Default value	Range	Definition	Unit
P00-16	Number of instruction pulses when the motor rotates one circle	Shutdown setting	Effective immediately	10000	0 to 131072	Set the number of position command pulses required for each turn of the motor. When the setting value is 0, [P00-17]/[P00-19] Electronic gear 1/2 numerator, [P00-18]/[P00-20] Electronic gear 1/2 denominator is valid.	Instruction pulse unit
P00-17	Electronic gear 1 numerator	Operation setting	Effective immediately	1	1 to 4294967294	Set the numerator of the 1st group electronic gear ratio for position instruction frequency division or multiplication. P00-16 is effective when the number of instruction pulses of one motor rotation is 0. VD2L: 1-2147483647	-
P00-18	Electronic gear 1 denominator	Operation setting	Effective immediately	1	1 to 4294967294	Set the denominator of the 1st group electronic gear ratio for position instruction frequency division or multiplication. P00-16 is effective when the number of instruction pulses	-

						of one motor rotation is 0. VD2L: 1-2147483647	
P00-19	Electronic gear 2 numerator	Operation setting	Effective immediately	1	1 to 4294967294	Set the numerator of the 2nd group electronic gear ratio for position instruction frequency division or multiplication. P00-16 is effective when the number of instruction pulses of one motor rotation is 0. VD2L: 1-2147483647	-
P00-20	Electronic gear 2 denominator	Operation setting	Effective immediately	1	1 to 4294967294	Set the denominator of the 2nd group electronic gear ratio for position instruction frequency division or multiplication. P00-16 is effective when the number of instruction pulses of one motor rotation is 0. VD2L: 1-2147483647	-

Table 6-22 Electronic gear ratio function code

To use electronic gear ratio 2, it is necessary to configure any DI port as function 09 (GEAR-SEL electronic gear switch 1), and determine the valid logic of the DI terminal.

DI function code	Function name	Function
09	GEAR-SEL electronic gear switch 1	DI port logic invalid: electronic gear ratio 1 DI port logic valid: electronic gear ratio 2

Table 6-23 Switching conditions of electronic gear ratio group

P00-16 value	DI terminal level corresponding to DI port function 9	Electronic gear ratio $\frac{A}{B}$
0	DI port logic invalid	$\frac{P00 - 17}{P00 - 18}$
	DI port logic valid	$\frac{P00 - 19}{P00 - 20}$
1 to 131072	--	$\frac{\text{Encoder resolution}}{P00 - 16}$

Table 6-24 Application of electronic gear ratio

When the function code P00-16 is not 0, the electronic gear ratio $\frac{A}{B}$ is invalid.

6.2.3 Position instruction filtering

Position instruction filtering is to filter the position instruction (encoder unit) after the electronic gear ratio frequency division or frequency multiplication, including first-order low-pass filtering and average filtering operation.

In the following situations, position instruction filtering should be added.

- ① The position instruction output by host computer has not been processed with acceleration or deceleration;
- ② The pulse instruction frequency is low;
- ③ When the electronic gear ratio is 10 times or more.

Reasonable setting of the position loop filter time constant can operate the motor more smoothly, so that the motor speed will not overshoot before reaching the stable point. This setting has no effect on the number of instruction pulses. The filter time is not as long as possible. If the filter time is longer, the delay time will be longer too, and the response time will be correspondingly longer. It is an illustration of several kinds of position filtering.

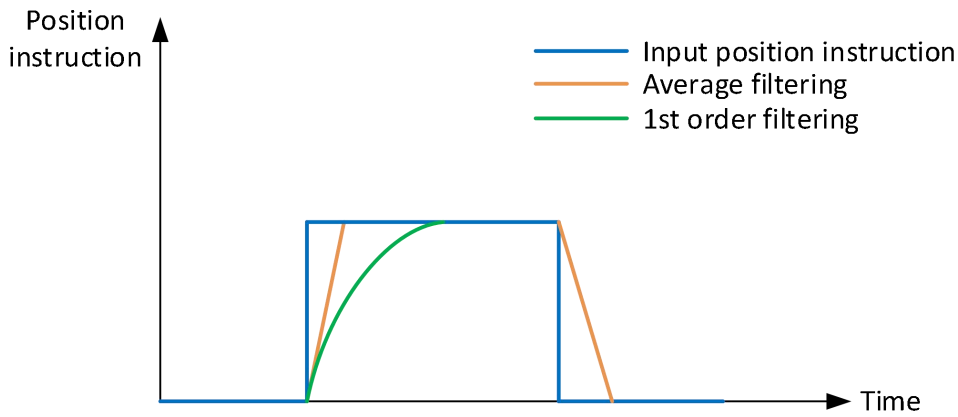

Figure 6-25 Position instruction filtering diagram

Function code	Name	Setting method	Effective time	Default value	Range	Definition	Unit
P04-01	Pulse instruction filtering method	Shutdown setting	Effective immediately	0	0 to 1	0: 1st-order low-pass filtering 1: Average filtering	-
P04-02	Position instruction 1st-order low-pass filtering time constant	Shutdown setting	Effective immediately	0	0 to 1000	Position instruction first-order low-pass filtering time constant	ms
P04-03	Position instruction average filtering time constant	Shutdown setting	Effective immediately	0	0 to 128	Position instruction average filtering time constant	ms

Table 6-25 Position instruction filter function code

6.2.4 Clearance of position deviation

Position deviation clearance means that the drive could zero the deviation register in position mode. The user can realize the function of clearing the position deviation through the DI terminal;

Position deviation = (position instruction - position feedback) (encoder unit)

6.2.5 Position-related DO output function

The feedback value of position instruction is compared with different thresholds, and output DO signal for host computer use.

Positioning completion/positioning approach output

The positioning completion function means that when the position deviation meets the value set by P05-12, it could be considered that the positioning is complete in position control mode. At this time, servo drive could output the positioning completion signal, and the host computer could confirm the completion of the positioning of servo drive after receiving the signal.

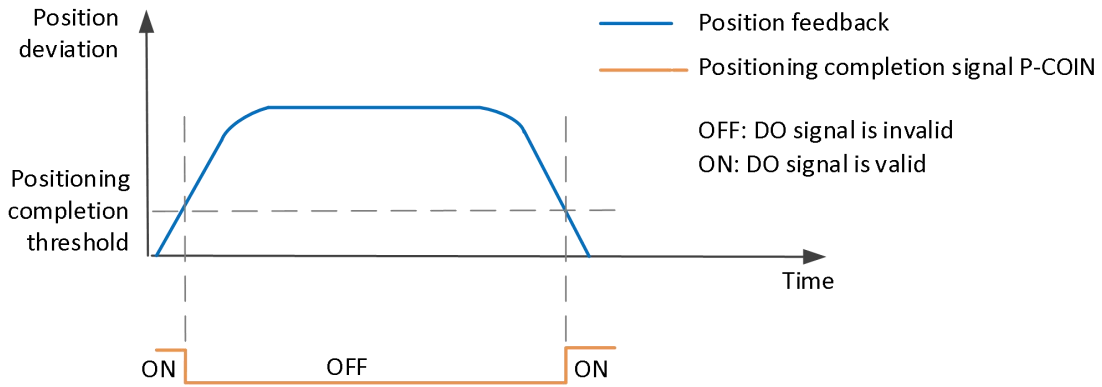

Figure 6-26 Positioning completion signal output diagram

When using the positioning completion or approach function, you could also set positioning completion, positioning approach conditions, window and hold time. The principle of window filter time is shown in Figure 6-27

To use the positioning completion/positioning approach function, a DO terminal of the servo drive should be assigned to the function 134 (P-COIN, positioning completion)/ 135 (P-NEAR, positioning approach). The related code parameters and DO function codes are shown as [Table 6-24](#).

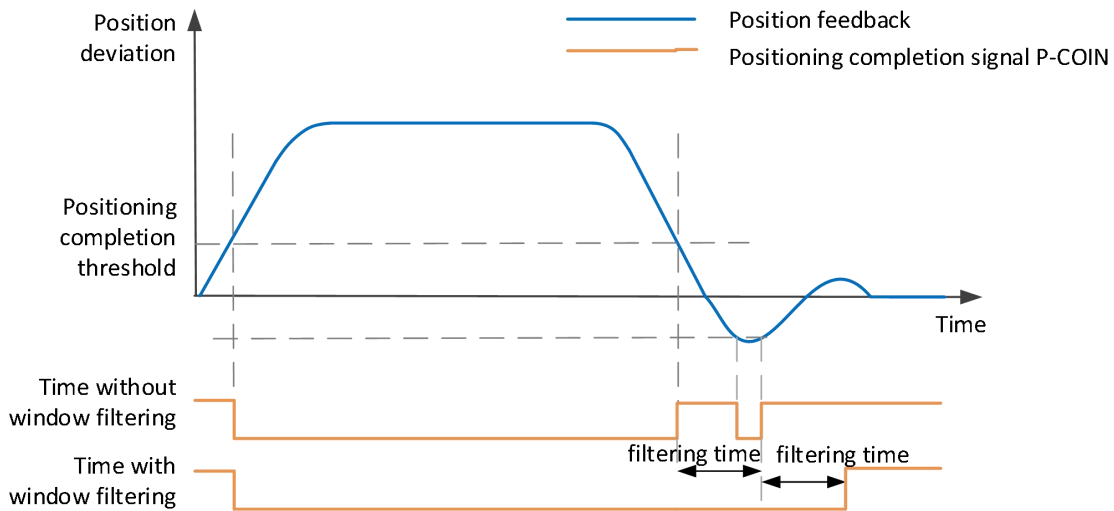

Figure 6-27 Positioning completion signal output with increased window filter time diagram

Function code	Name	Setting method	Effective time	Default value	Range	Definition	Unit
P05-12	Positioning completion threshold	Operation setting	Effective immediately	800	1 to 65535	Positioning completion threshold	Equivalent pulse unit
P05-13	Positioning approach threshold	Operation setting	Effective immediately	5000	1 to 65535	Positioning approach threshold	Equivalent pulse unit
P05-14	Position detection window time	Operation setting	Effective immediately	10	0 to 20000	Set positioning completion detection window time	ms
P05-15	Positioning signal hold time	Operation setting	Effective immediately	100	0 to 20000	Set positioning completion output hold time	ms

Table 6-26 Function code parameters of positioning completion

DO function code	Function name	Function
134	P-COIN positioning complete	Output this signal indicates the servo drive position is complete.
135	P-NEAR positioning close	Output this signal indicates that the servo drive position is close.

Table 6-27 Description of DO rotation detection function code

6.2.6 VD2-0xxSA1H collector pulse signal DO Function and VD2L pulse signal DO output function

(1) VD2-0xxSA1H collector pulse signal DO Function

The pulse signal of VD2-0xxSA1H is a collector signal output through DO, which can be connected to the high-speed pulse input of PLC without conversion through differential to collector circuit board. However, the pulse frequency division output used by VD2 series is a differential signal, which needs to pass through differential to collector circuit board to be connected to the high-speed pulse input of PLC.

(2) Pulse signal DO output function of VD2L-0xxSA1P

The pulse signal of VD2L-0xxSA1P is the collector signal output by DO, and it can be connected to the high-speed pulse input of PLC without the conversion of differential to collector circuit board.

(3) The difference of collector pulse signal DO Function of VD2-0xxSA1H and DO output function of pulse signal of VD2L-0xxSA1P

The pulse signal of VD2-0xxSA1H is the collector signal output through DO, and it is a 4 times frequency pulse signal of Phase A/B. DO signal of VD2L is a pulse+direction signal.

DO2, DO3, and DO4 respectively correspond to the pulse frequency division outputs of the Z-axis, A-axis, and B-axis of the pulse output, as shown in the following table.

P06-28	Parameter name	Setting method	Effective time	Default	Set range	Application category	Unit
	DO_2 channel function selection	Operation setting	Effective immediately	143	128-148	DI/DO	-

Used to set DO functions corresponding to hardware DO2. Refer to the following table for the functions corresponding to the set value:

Setting value	DO channel function	Setting value	DO channel function
128	OFF (not used)	139	T-LIMIT (Torque limit)
129	RDY (Servo ready)	140	V-LIMIT (speed limited)
130	ALM (fault signal)	141	BRK-OFF (Brake Output) ^{Note¹}
131	WARN (warning signal)	142	SRV-ST (Servo start status output)
132	TGON (rotation detection)	143	OZ (Z pulse output) ^{Note²}
133	ZSP (zero speed signal)	144	N/A
134	P-COIN (Positioning completed)	145	COM_VDO1 (communication VDO1 output)
135	P-NEAR (positioning approach)	146	COM_VDO1(Communication VDO2 output)
136	V-COIN (consistent speed)	147	COM_VDO1(communication VDO3 output)
137	V-NEAR (speed approach)	148	COM_VDO1(communication VDO4 output)
138	T-COIN (torque arrival)		

When P06-28 is set to a value other than the above table, it is considered to not use DO port function.

The same DO channel function is not allowed to be assigned to multiple DO ports, otherwise the servo driver will report A-90 (DO port configuration duplicate).

Note 1: To use the BRK-OFF function code, you need to repower to take effect.

Note 2:

- ① Only VD2L and VD2F support function code 143. The code for this function of VD2-0xxSA1G model is empty!
- ② Only in the VD2-0xxSA1H model, the default function code for the DO_1 channel function selection is 130ALM (fault signal)! In the VD2-0xxSA1H model, the function code for the DO_2, DO_3, and DO_4 channels are 143 OZ (Z/A/B pulse output), and these 3 channels correspond to the Z-axis, A-axis, and B-axis of the pulse output respectively!
- ③ The function selection code of DO_2, DO_3 and DO_4 channels in the VD2L-0xxSA1P model are 143 OZ (Z pulse output), and these 3 channels correspond to Z axis, pulse axis, and direction axis of the pulse output respectively!

P06-30	Parameter name	Setting method	Effective time	Default	Set range	Application category	Unit
	DO_3 channel function selection	Operation setting	Effective immediately	143	128-148	DI/DO	-

Used to set DO functions corresponding to hardware DO3. Refer to the following table for the functions corresponding to the set value:

Setting value	DO channel function	Setting value	DO channel function
128	OFF (not used)	139	T-LIMIT (torque limit)
129	RDY (Servo ready)	140	V-LIMIT (speed limited)
130	ALM (fault signal)	141	BRK-OFF (Brake Output) ^{Note¹}
131	WARN (warning signal)	142	SRV-ST (Servo start status output)
132	TGON (rotation detection)	143	OA (A pulse output) ^{Note²}
133	ZSP (zero speed signal)	144	None
134	P-COIN (Positioning completed)	145	COM_VDO1 (communication VDO1 output)
135	P-NEAR (positioning approach)	146	COM_VDO1(Communication VDO2 output)
136	V-COIN (consistent speed)	147	COM_VDO1(communication VDO3 output)
137	V-NEAR (speed approach)	148	COM_VDO1(communication VDO4 output)
138	T-COIN (torque arrival)		

When P06-30 is set to a value other than the above table, it is considered to not use DO port function.

The same DO channel function is not allowed to be assigned to multiple DO ports, otherwise the servo driver will report A-90 (DO port configuration duplicate).

Note 1: To use the BRK-OFF function code, you need to repower to take effect.

Note 2:

- ① Only VD2L and VD2F support function code 143. The code for this function of VD2-0xxSA1G model is empty!
- ② Only in the VD2-0xxSA1H model, the default function code for the DO_1 channel function selection is 130ALM (fault signal)! In the VD2-0xxSA1H model, the function code for the DO_2, DO_3, and DO_4 channels are 143 OZ (Z/A/B pulse output), and these 3 channels correspond to the Z-axis, A-axis, and B-axis of the pulse output respectively!
- ③ The function selection code of DO_2, DO_3 and DO_4 channels in the VD2L-0xxSA1P model are 143 OZ (Z pulse output), and these 3 channels correspond to Z axis, pulse axis, and direction axis of the pulse output respectively!

P06-32	Parameter name	Setting method	Effective time	Default	Set range	Application category	Unit
	DO_4 channel function selection	Operation setting	Effective immediately	143	128-148	DI/DO	-

Used to set DO functions corresponding to hardware DO4. Refer to the following table for the functions corresponding to the set value:

Setting value	DO channel function	Setting value	DO channel function
128	OFF (not used)	139	T-LIMIT (Torque limit)
129	RDY (Servo ready)	140	V-LIMIT (speed limited)
130	ALM (fault signal)	141	BRK-OFF (Brake Output) ^{Note¹}
131	WARN (warning signal)	142	SRV-ST (Servo start status output)
132	TGON (rotation detection)	143	OB (B pulse output) ^{Note²}
133	ZSP (zero speed signal)	144	None
134	P-COIN (Positioning completed)	145	COM_VDO1 (communication VDO1 output)
135	P-NEAR (positioning approach)	146	COM_VDO1(Communication VDO2 output)
136	V-COIN (consistent speed)	147	COM_VDO1(communication VDO3 output)
137	V-NEAR (speed approach)	148	COM_VDO1(communication VDO4 output)
138	T-COIN (torque arrival)		

When P06-32 is set to a value other than the above table, it is considered to not use DO port function.

The same DO channel function is not allowed to be assigned to multiple DO ports, otherwise the servo drive will report A-90 (DO port configuration duplicate).

Note 1: To use the BRK-OFF function code, you need to repower to take effect.

Note 2:

① Only VD2L and VD2F support function code 143. The code for this function of VD2-0xxSA1G model is empty!

② Only in the VD2-0xxSA1H model, the default function code for the DO_1 channel function selection is 130ALM (fault signal)! In the VD2-0xxSA1H model, the function code for the DO_2, DO_3, and DO_4 channels are 143 OZ (Z/A/B pulse output), and these 3 channels correspond to the Z-axis, A-axis, and B-axis of the pulse output respectively!

③ The function selection code of DO_2, DO_3 and DO_4 channels in the VD2L-0xxSA1P model are 143 OZ (Z pulse output), and these 3 channels correspond to Z axis, pulse axis, and direction axis of the pulse output respectively!

6.3 Speed control mode

Speed control refers to controlling the speed of the machine through speed instructions. Given the speed instruction by digital voltage or communication, the servo drive can control the mechanical speed fast and precisely. Therefore, the speed control mode is mainly used to control the rotation speed such as analog CNC engraving and milling machine. [Figure 6-28](#) is the speed control block diagram.

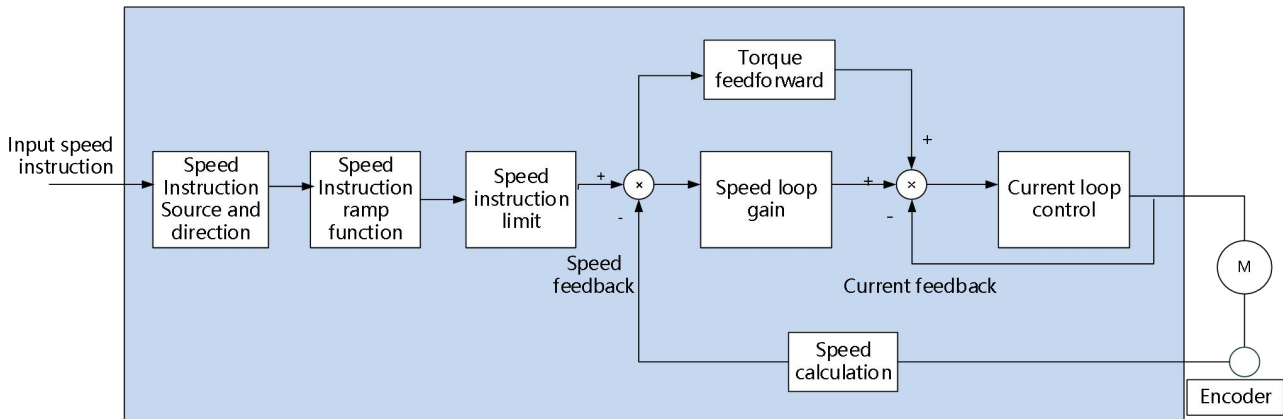

Figure 6-28 Speed control block diagram

6.3.1 Speed instruction input setting

In speed control mode, VD2A and VD2B servo drives have two instruction sources: internal speed instruction and analog speed instruction. VD2F drive only supports internal speed instruction. Speed instruction source is set by function code P01-01.

Function code	Name	Setting method	Effective time	Default value	Range	Definition	Unit
P01-01	Speed instruction source	Shutdown setting	Effective immediately	0	0 to 1	0: Internal speed instruction 1: AI_1 analog input (not supported by VD2F/VD2L)	-

Table 6-28 Speed instruction source parameter

(1) Speed instruction source is internal speed instruction (P01-01=0)

Speed instruction comes from internal instruction, and the internal speed instruction is given by a number. VD2 series servo drive has internal multi-segment speed running function. There are 8 segments speed instructions stored in servo drive, and the speed of each segment could be set individually. The servo drive uses the 1st segment internal speed by default. To use the 2nd to 8th segment internal speed, the corresponding number of DI terminals must be configured as functions 13, 14, and 15. The detailed parameters and function codes are shown as below.

Function code	Name	Setting method	Effective time	Default value	Range	Definition	Unit
P01-02	Internal speed Instruction 0	Operation setting	Effective immediately	0	-5000 to 5000	Internal speed instruction 0 When DI input port: 15-INSPD3: 0 14-INSPD2: 0 13-INSPD1: 0, select this speed instruction to be effective.	rpm
P01-23	Internal speed Instruction 1	Operation setting	Effective immediately	0	-5000 to 5000	Internal speed instruction 1 When DI input port: 15-INSPD3: 0 14-INSPD2: 0 13-INSPD1: 1, Select this speed instruction to be effective.	rpm
P01-24	Internal speed Instruction 2	Operation setting	Effective immediately	0	-5000 to 5000	Internal speed instruction 2 When DI input port: 15-INSPD3: 0 14-INSPD2: 1 13-INSPD1: 0, Select this speed instruction to be effective.	rpm
P01-25	Internal speed Instruction 3	Operation setting	Effective immediately	0	-5000 to 5000	Internal speed instruction 3 When DI input port: 15-INSPD3: 0 14-INSPD2: 1 13-INSPD1: 1, Select this speed instruction to be effective.	rpm
P01-26	Internal speed Instruction 4	Operation setting	Effective immediately	0	-5000 to 5000	Internal speed instruction 4 When DI input port: 15-INSPD3: 1 14-INSPD2: 0 13-INSPD1: 0, Select this speed instruction to be effective.	rpm
P01-27	Internal speed Instruction 5	Operation setting	Effective immediately	0	-5000 to 5000	Internal speed instruction 5 When DI input port: 15-INSPD3: 1 14-INSPD2: 0 13-INSPD1: 1, Select this speed instruction to be effective.	rpm
P01-28	Internal speed Instruction 6	Operation setting	Effective immediately	0	-5000 to 5000	Internal speed instruction 6 When DI input port: 15-INSPD3: 1 14-INSPD2: 1 13-INSPD1: 0, Select this speed instruction to be effective.	rpm
P01-29	Internal speed Instruction 7	Operation setting	Effective immediately	0	-5000 to 5000	Internal speed instruction 7 When DI input port: 15-INSPD3: 1 14-INSPD2: 1	rpm

						13-INSPD1: 1, Select this speed instruction to be effective.	
--	--	--	--	--	--	--	--

Table 6-29 Internal speed instruction parameters

DI function code	function name	Function
13	INSPD1 internal speed instruction selection 1	Form internal multi-speed running segment number
14	INSPD2 internal speed instruction selection 2	Form internal multi-speed running segment number
15	INSPD3 internal speed instruction selection 3	Form internal multi-speed running segment number

Table 6-30 DI multi-speed function code description

The multi-speed segment number is a 3-bit binary number, and the DI terminal logic is level valid. When the input level is valid, the segment selection bit value is 1, otherwise it is 0. The corresponding relationship between INSPD1 to 3 and segment numbers is shown as below.

INSPD3	INSPD2	INSPD1	Running segment number	Internal speed instruction number
0	0	0	1	0
0	0	1	2	1
0	1	0	3	2
.....				
1	1	1	8	7

Table 6-31 Correspondence between INSPD bits and segment numbers

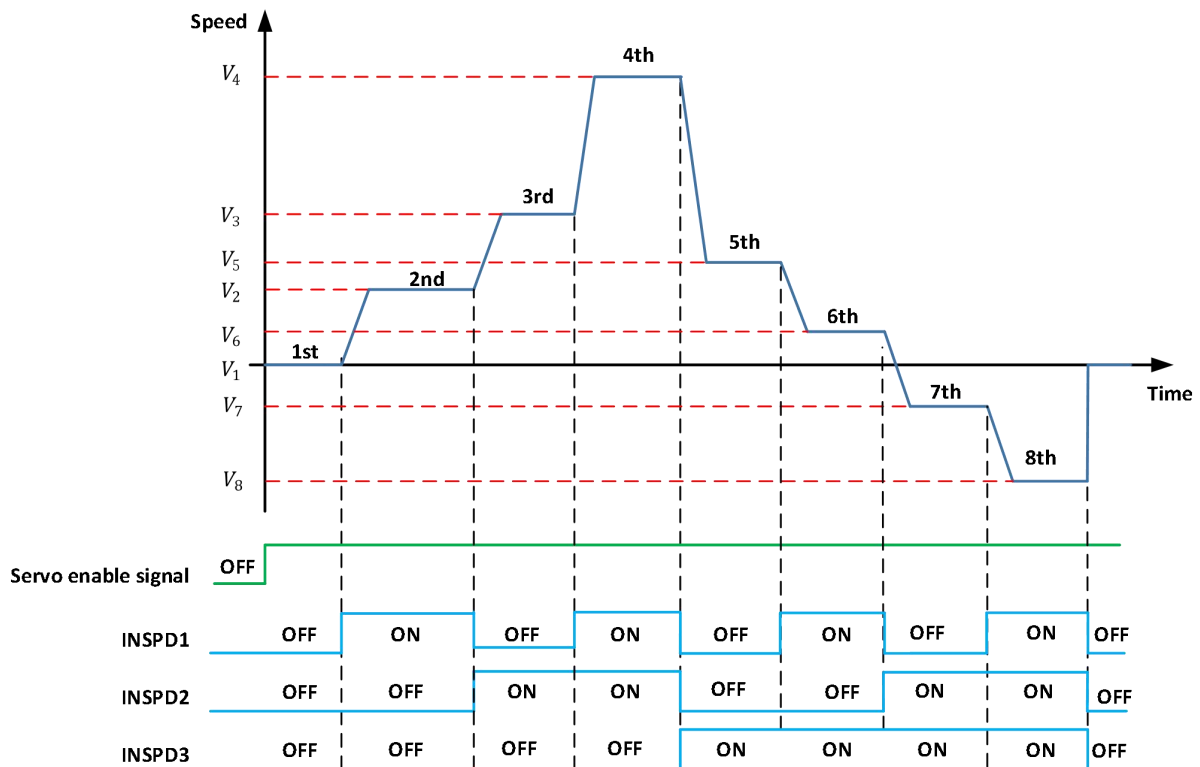

Figure 6-29 Multi-segment speed running curve

(2) Speed instruction source is internal speed instruction (P01-01=1)

The servo drive processes the analog voltage signal output by the host computer or other equipment as a speed instruction. VD2A and VD2B series servo drives have 2 analog input channels: AI_1 and AI_2. AI_1 is analog speed input, and AI_2 is analog speed limit.

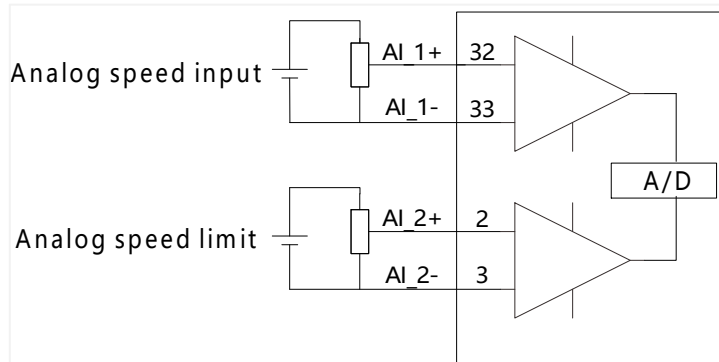

Figure 6-30 Analog input circuit

Taking AI_1 as an example, the method of setting the speed instruction of analog voltage is illustrated as below.

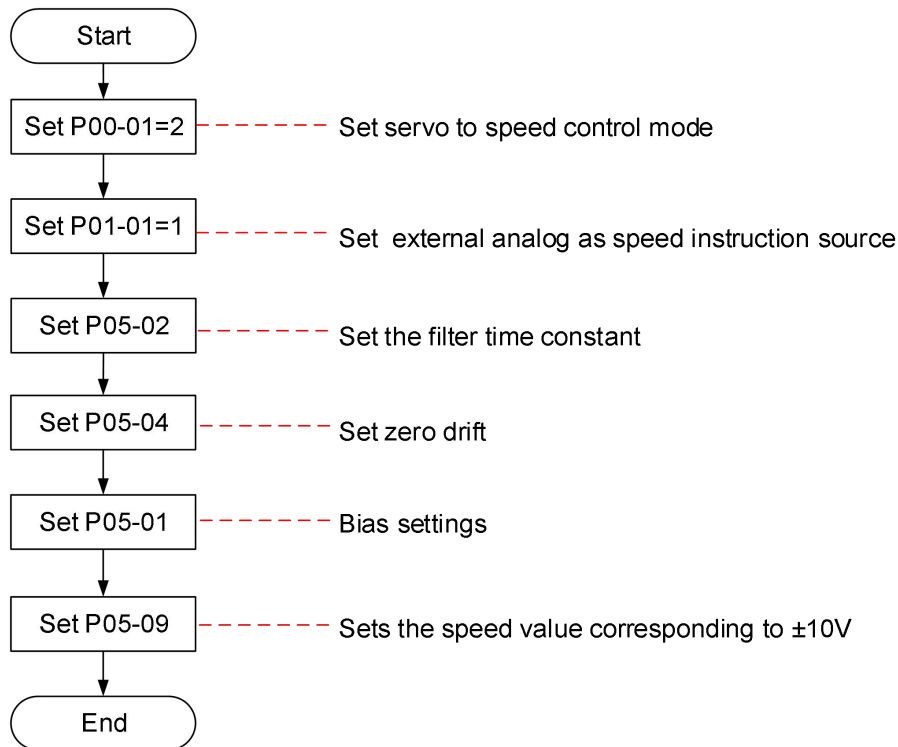

Figure 6-31 Analog voltage speed instruction setting steps

Explanation of related terms:

- Zero drift: When analog input voltage is 0, the servo drive sample voltage value relative to the value of GND.
- Bias: After zero drift correction, the corresponding analog input voltage when the sample voltage is 0.
- Dead zone: It is the corresponding analog input voltage interval when the sample voltage is 0.

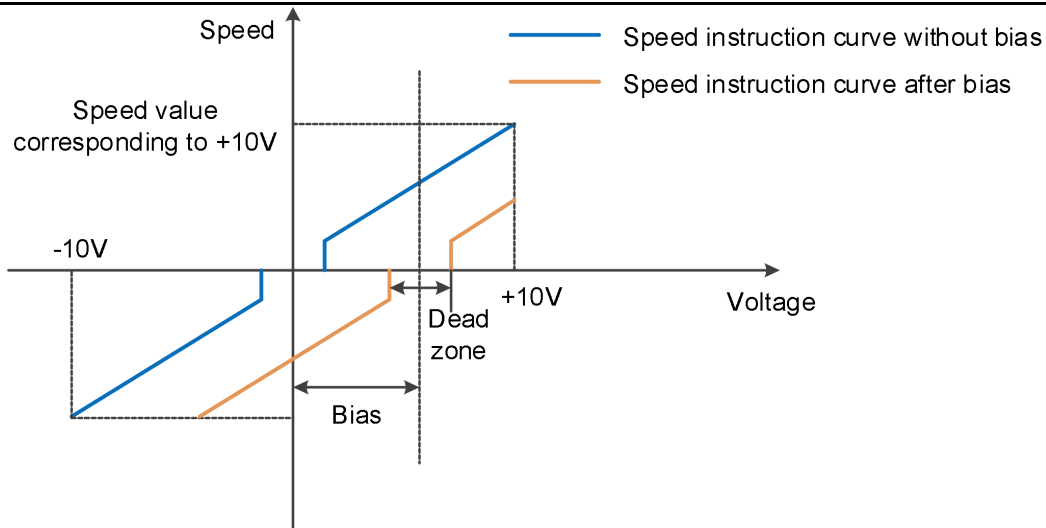

Figure 6-32 AI_1 diagram before and after bias

Function code	Name	Setting method	Effective time	Default value	Range	Definition	Unit
P05-01 ★	AI_1 input bias	Operation settings	Effective immediately	0	-5000 to 5000	Set AI_1 channel analog bias value	mV
P05-02 ★	AI_1 input filter time constant	Operation settings	Effective immediately	200	0 to 60000	AI_1 channel input first-order low-pass filtering time constant	0.01 ms
P05-03 ★	AI_1 dead zone	Operation settings	Effective immediately	20	0 to 1000	Set AI_1 channel quantity dead zone value	mV
P05-04 ★	AI_1 zero drift	Operation settings	Effective immediately	0	-500 to 500	Automatic calibration of zero drift inside the drive	mV

Table 6-32 AI_1 parameter

Note:

- ☆: Indicates that the VD2F servo drive does not support this function code
- : Indicates that the VD2F servo drive does not support this function code
- ★: Indicates that VD2F and VD2L servo drives do not support this function code

6.3.2 Acceleration and deceleration time setting

The acceleration and deceleration time setting can achieve the expectation of controlling acceleration by converting the speed instruction with higher acceleration into the speed instruction with gentle acceleration.

In the speed control mode, excessive acceleration of the speed instruction will cause the motor to jump or vibrate. Therefore, a suitable acceleration and deceleration time can realize the smooth speed change of the motor and avoid the occurrence of mechanical damage caused by the above situation.

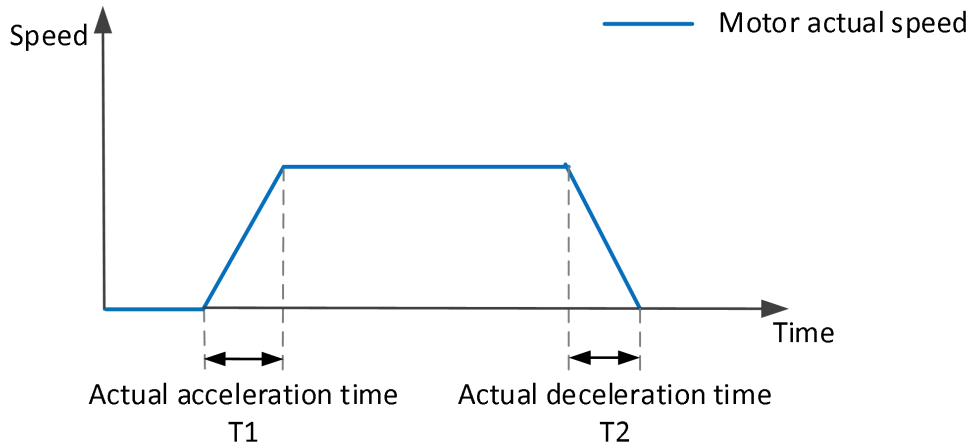

Figure 6-33 of acceleration and deceleration time diagram

$$\text{Actual acceleration time } T1 = \frac{\text{speed instruction}}{1000} \times \text{acceleration time}$$

$$\text{Actual deceleration time } T2 = \frac{\text{speed instruction}}{1000} \times \text{deceleration time}$$

Function code	Name	Setting method	Effective time	Default value	Range	Definition	Unit
P01-03	Acceleration time	Operation setting	Effective immediately	50	0 to 65535	The time for the speed instruction to accelerate from 0 to 1000rpm	ms
P01-04	Deceleration time	Operation setting	Effective immediately	50	0 to 65535	The time for the speed instruction to decelerate from 1000rpm to 0	ms

Table 6-31 Acceleration and deceleration time parameters

6.3.3 Speed instruction limit

In speed mode, the servo drive could limit the size of the speed instruction. The sources of speed instruction limit include:

- ① P01-10: Set the maximum speed limit value
- ② P01-12: Set forward speed limit value
- ③ P01-13: Set reverse speed limit value
- ④ The maximum speed of the motor: determined by motor model

The actual motor speed limit interval satisfies the following relationship:

The amplitude of forward speed instruction $\leq \min$ (Maximum motor speed, P01-10, P01-12)

The amplitude of negative speed command $\leq \min$ (Maximum motor speed, P01-10, P01-13)

Function code	Name	Setting method	Effective time	Default value	Range	Definition	Unit
P01-10	Maximum speed threshold	Operation setting	Effective immediately	3600	0 to 5000	Set the maximum speed limit value, if exceeds this value, an overspeed fault will be reported	rpm
P01-12	Forward speed threshold	Operation setting	Effective immediately	3000	0 to 5000	Set forward speed limit value	rpm
P01-13	Reverse speed threshold	Operation setting	Effective immediately	3000	0 to 5000	Set reverse speed limit value	rpm

Table 6-34 Rotation speed related function codes

6.3.4 Zero-speed clamp function

The zero speed clamp function refers to the speed control mode, when the zero speed clamp signal (ZCLAMP) is valid, and the absolute value of the speed instruction is lower than the zero speed clamp speed threshold (P01-22), the servo motor is at In locked state, the servo drive is in position lock mode at this time, and the speed instruction is invalid.

If the speed instruction amplitude is greater than zero-speed clamp speed threshold, the servo motor exits the locked state and continues to run according to the current input speed instruction.

Function code	Name	Setting method	Effective time	Default value	Range	Definition	Unit
P01-21	Zero-speed clamp function selection	Operation setting	Effective immediately	0	0 to 3	Set the zero-speed clamp function. In speed mode: 0: Force the speed to 0; 1: Force the speed to 0, and keep the position locked when the actual speed is less than P01-22 2: When speed instruction is less than P01-22, force the speed to 0 and keep the position locked 3: Invalid, ignore zero-speed clamp input	-
P01-22	Zero-speed clamp speed threshold	Operation setting	Effective immediately	20	0 to 1000	Set the speed threshold of zero-speed clamp function	rpm

Table 6-35 Zero-speed clamp related parameters

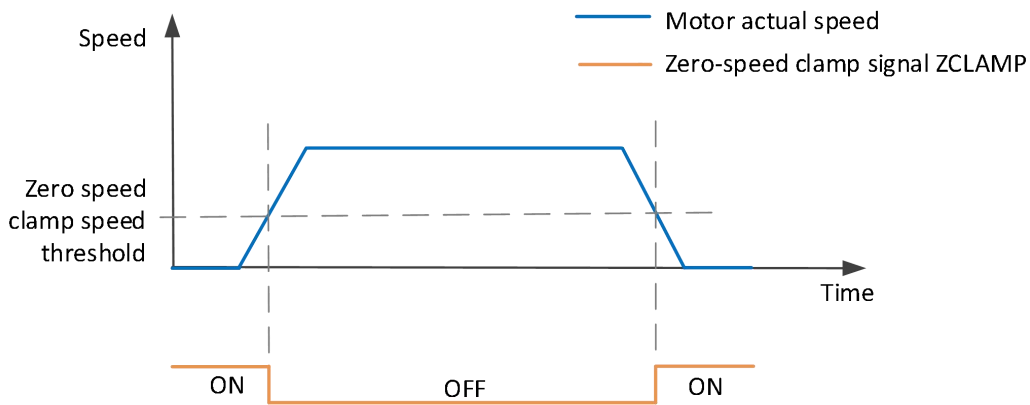

Figure 6-34 Zero-speed clamp diagram

6.3.5 Speed-related DO output function

The feedback value of the position instruction is compared with different thresholds, and could output DO signal for host computer use.

(1) Rotation detection signal

After the speed instruction is filtered, the absolute value of the actual speed absolute value of the servo motor reaches P05-16 (rotation detection speed threshold), it could be considered that the motor is rotating. At this time, the servo drive outputs a rotation detection signal (TGON), which can be used to confirm that the motor has rotated. On the contrary, when the absolute value of the

actual rotation speed of the servo motor is less than P05-16, it is considered that the motor is not rotating.

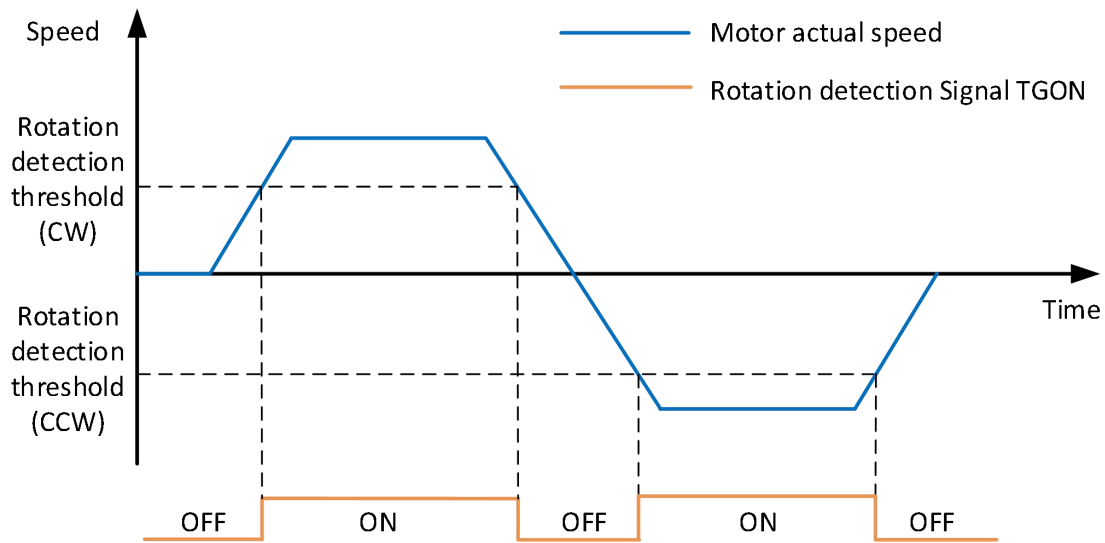

Figure 6-35 Rotation detection signal diagram

To use the motor rotation detection signal output function, a DO terminal of the servo drive should be assigned to function 132 (T-COIN, rotation detection). The function code parameters and related DO function codes are shown in [Table 6-34](#) and [Table 6-35](#).

Function code	Name	Setting method	Effective time	Default value	Range	Definition	Unit
P05-16	Rotation detection speed threshold	Operation setting	Effective immediately	20	0 to 1000	Set the motor rotation signal judgment threshold	rpm

Table 6-36 Rotation detection speed threshold parameters

DO function code	Function name	Function
132	T-COIN rotation detection	Valid: when the absolute value of motor speed after filtering is greater than or equal to the set value of function code P05-16 Invalid, when the absolute value of motor speed after filtering is less than set value of function code P05-16

Table 6-37 DO rotation detection function code

(2) Zero-speed signal

If the absolute value of the actual speed of servo motor is less than a certain threshold P05-19, it is considered that servo motor stops rotating (close to a standstill), and the servo drive outputs a zero-speed signal (ZSP) at this time. On the contrary, if the absolute value of the actual speed of the servo motor is not less than this value, it is considered that the motor is not at a standstill and the zero-speed signal is invalid.

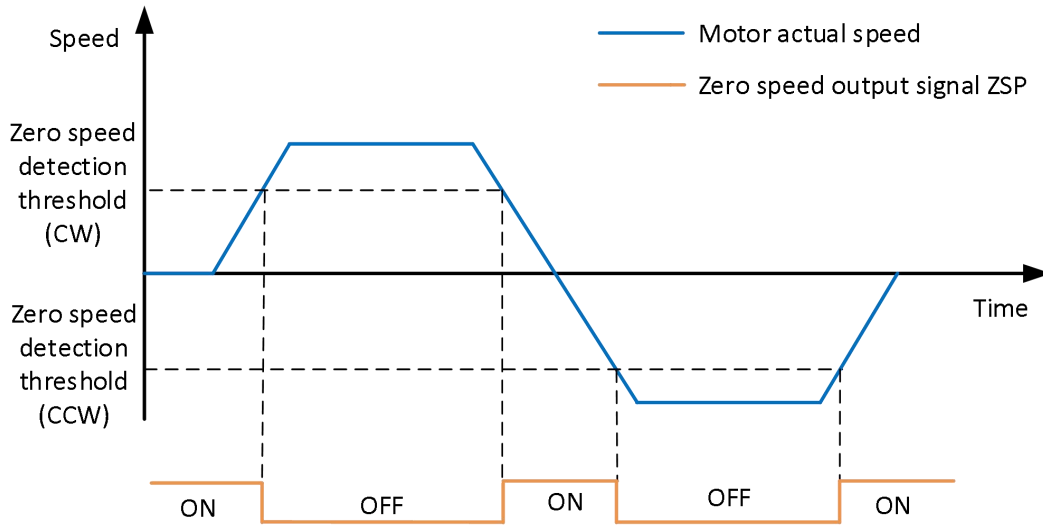

Figure 6-36 Zero-speed signal diagram

To use the motor zero-speed signal output function, a DO terminal of servo drive should be assigned to function 133 (ZSP, zero-speed signal). The function code parameters and related DO function codes are shown in [Table 6-36](#) and [Table 6-37](#).

Function code	Name	Setting method	Effective time	Default value	Range	Definition	Unit
P05-19	Zero speed output signal threshold	Operation setting	Effective immediately	10	0 to 6000	Set zero-speed output signal judgment threshold	rpm

Table 6-38 Zero-speed output signal threshold parameter

DO function code	Function name	Function
133	ZSP zero speed signal	Output this signal indicates that the servo motor is stopping rotation

Table 6-39 DO zero-speed signal function code

(3) Speed consistent signal

When the absolute value of the deviation between the actual speed of the servo motor after filtering and the speed instruction meets a certain threshold P05-17, it is considered that the actual speed of the motor has reached the set value, and the servo drive outputs a speed coincidence signal (V-COIN) at this time. Conversely, if the absolute value of the deviation between the actual speed of the servo motor and the set speed instruction after filtering exceeds the threshold, the speed consistent signal is invalid.

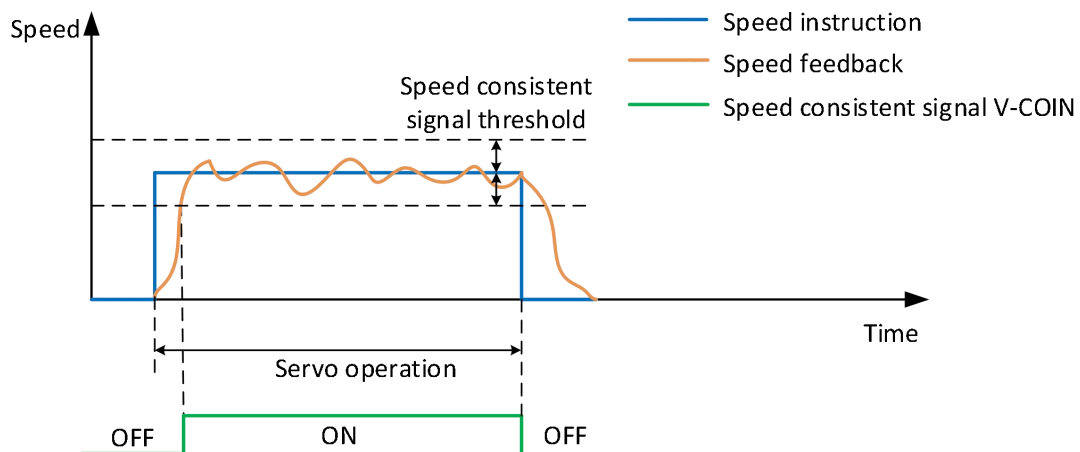

Figure 6-37 Speed consistent signal diagram

To use the motor speed consistent function, a DO terminal of the servo drive should be assigned to function 136 (V-COIN, consistent speed). The function code parameters and related DO function codes are shown in [Table 6-38](#) and [Table 6-39](#).

Function code	Name	Setting method	Effective time	Default value	Range	Definition	Unit
P05-17	Speed consistent signal threshold	Operation setting	Effective immediately	10	0 to 100	Set speed consistent signal threshold	rpm

Table 6-38 Speed consistent signal threshold parameters

DO Function code	Function name	Function
136	U-COIN consistent speed	The output signal indicates that the absolute deviation of the actual speed of servo motor and the speed instruction meets the P05-17 set value

Table 6-39 DO speed consistent function code

(4) Speed approach signal

After filtering, the absolute value of the actual speed of the servo motor exceeds a certain threshold [P05-17], and it is considered that the actual speed of the servo motor has reached the expected value. At this time, the servo drive can output a speed close signal (V-NEAR) through the DO terminal. Conversely, if the absolute value of the actual speed of the servo motor after filtering is not greater than this value, the speed approach signal is invalid.

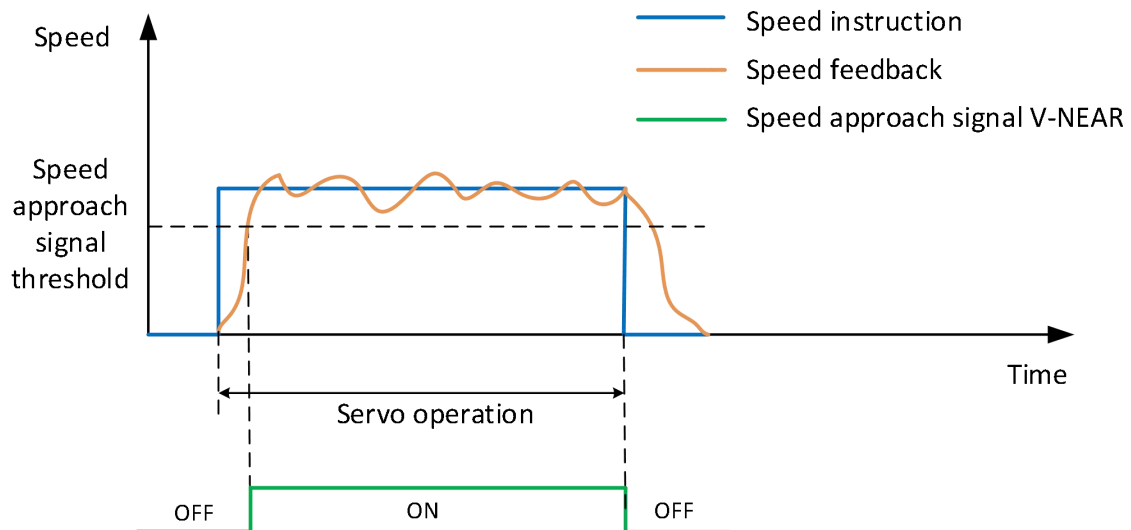

Figure 6-38 Speed approaching signal diagram

To use the motor speed approach function, a DO terminal of the servo drive should be assigned to function 137 (V-NEAR, speed approach). The function code parameters and related DO function codes are shown in [Table 6-40](#) and [Table 6-41](#).

Function code	Name	Setting method	Effective time	Default value	Range	Definition	Unit
P05-18	Speed approach signal threshold	Operation setting	Effective immediately	100	10 to 6000	Set speed approach signal threshold	rpm

Table 6-42 Speed approaching signal threshold parameters

DO function code	Function name	Function
137	V-NEAR speed approach	The output signal indicates that the actual speed of the servo motor has reached the expected value

Table 6-43 DO speed approach function code

6.4 Torque control mode

The current of the servo motor has a linear relationship with the torque. Therefore, the control of the current can realize the control of the torque. Torque control refers to controlling the output torque of the motor through torque instructions. Torque instruction could be given by internal instruction and analog voltage.

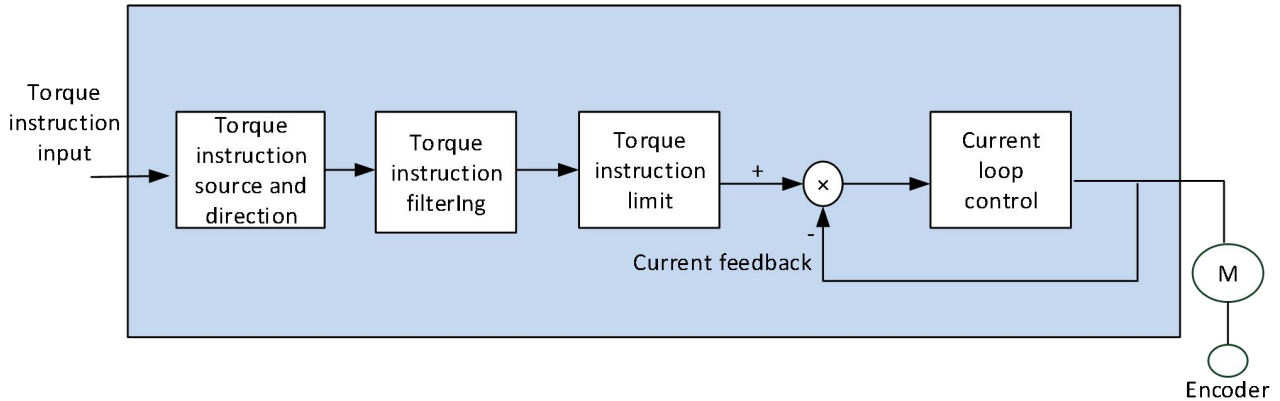

Figure 6-39 Torque mode diagram

6.4.1 Torque instruction input setting

In torque instruction, VD2A and VD2B servo drives have two instruction sources: internal torque instruction and analog torque instruction. VD2F and VD2L drive only has internal torque instruction. The torque instruction source is set by the function code P01-07.

Function code	Name	Setting method	Effective time	Default value	Range	Definition	Unit
P01-07	Torque instruction source	Shutdown settings	Effective immediately	0	0 to 1	0: internal torque instruction 1: AI_1 analog input (not supported by VD2F and VD2L)	-

Table 6-44 Torque instruction source parameter

(1) Torque instruction source is internal torque instruction (P01-07=0)

Torque instruction source is from inside, the value is set by function code P01-08.

Function code	Name	Setting method	Effective time	Default value	Range	Definition	Unit
P01-08	Torque instruction keyboard set value	Operation setting	Effective immediately	0	-3000 to 3000	-300.0% to 300.0%	0.1%

Table 6-45 Torque instruction keyboard set value

(2) Torque instruction source is analog torque instruction (P01-07=1)

The servo drive processes the analog voltage signal output by host computer or other equipment as torque instruction. VD2A and VD2B series servo drives have 2 analog input channels: AI_1 and AI_2. AI_1 is analog torque input, and AI_2 is analog torque limit.

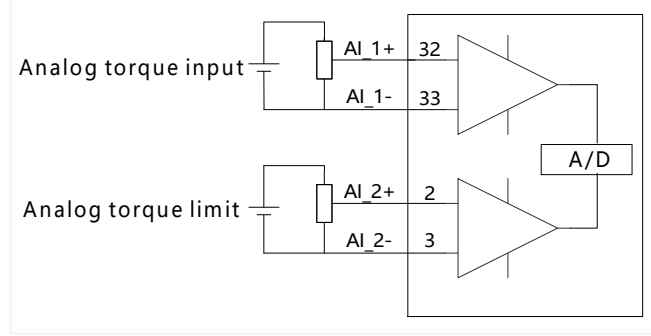

Figure 6-40 Analog input circuit

Taking AI_1 as an example, the method of setting torque instruction of analog voltage is as below.

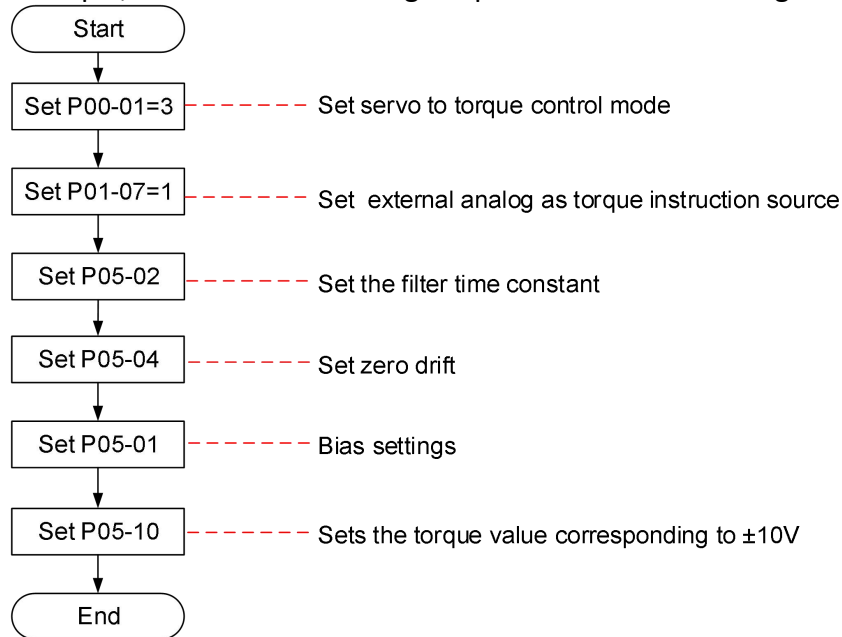

Figure 6-41 Analog voltage torque instruction setting steps

Explanation of related terms:

- Zero drift: When analog input voltage is 0, the servo drive sample voltage value relative to the value of GND.
- Bias: After zero drift correction, the corresponding analog input voltage when the sample voltage is 0.
- Dead zone: It is the corresponding analog input voltage interval when the sample voltage is 0.

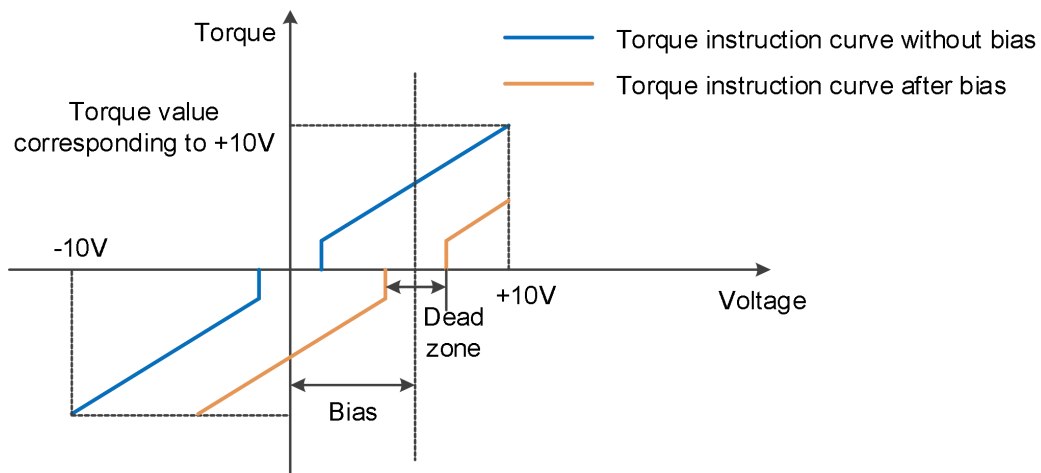

Figure 6-42 AI_1 diagram before and after bias

Function code	Name	Setting method	Effective time	Default value	Range	Definition	Unit
P05-01 ★	AI_1 input bias	Operation setting	Effective immediately	0	-5000 to 5000	Set AI_1 channel analog bias value	mV
P05-02 ★	AI_1 input filter time constant	Operation setting	Effective immediately	200	0 to 60000	AI_1 channel input first-order low-pass filtering time constant	0.01 ms
P05-03 ★	AI_1 dead zone	Operation setting	Effective immediately	20	0 to 1000	Set AI_1 channel dead zone value	mV
P05-04 ★	AI_1 zero drift	Operation setting	Effective immediately	0	-500 to 500	Automatic calibration of zero drift inside the drive	mV

Table 6-46 AI_1 parameter

Note:

☆: Indicates that the VD2F servo drive does not support this function code

○: Indicates that the VD2F servo drive does not support this function code

★: Indicates that VD2F and VD2L servo drives do not support this function code

6.4.2 Torque instruction filtering

In torque mode, the servo drive could realize low-pass filtering of torque instruction, making the instruction smoother and reducing the vibration of servo motor. The first-order filtering is shown in [Figure 6-43](#).

Function code	Name	Setting method	Effective time	Default value	Range	Definition	Unit
P04-04	Torque filtering time constant	Operation setting	Effective immediately	50	10 to 2500	This parameter is automatically set when "self-adjustment mode selection" is selected as 0	0.01ms

Table 6-47 Torque filtering time constant parameter details

Note: If the filter time constant is set too large, the responsiveness will be reduced. Please set it while confirming the responsiveness.

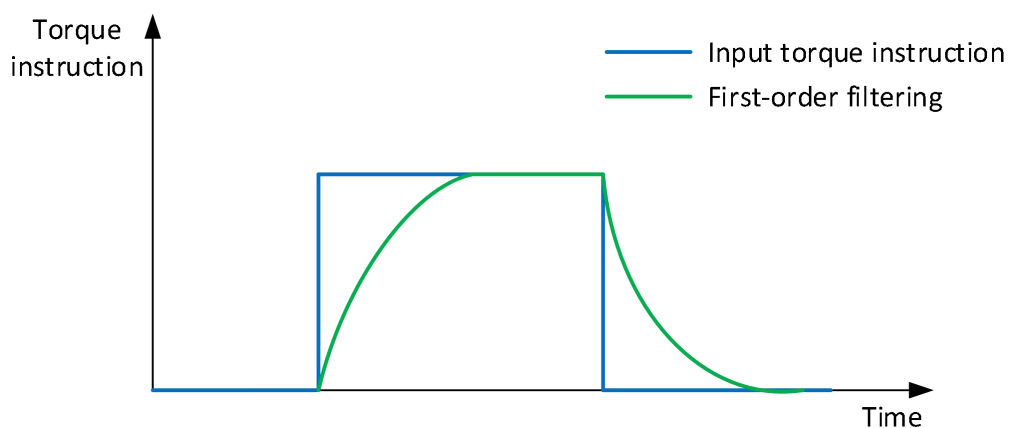

Figure 6-43 Torque instruction-first-order filtering diagram

6.4.3 Torque instruction limit

When the absolute value of torque instruction input by host computer is greater than the absolute value of torque instruction limit, the drive's actual torque instruction is limited and equal to the

limit value of torque instruction. Otherwise, it is equal to the torque instruction value input by host computer.

At any time, there is only one valid torque limit value. And the positive and negative torque limit values do not exceed the maximum torque of drive and motor and $\pm 300.0\%$ of the rated torque.

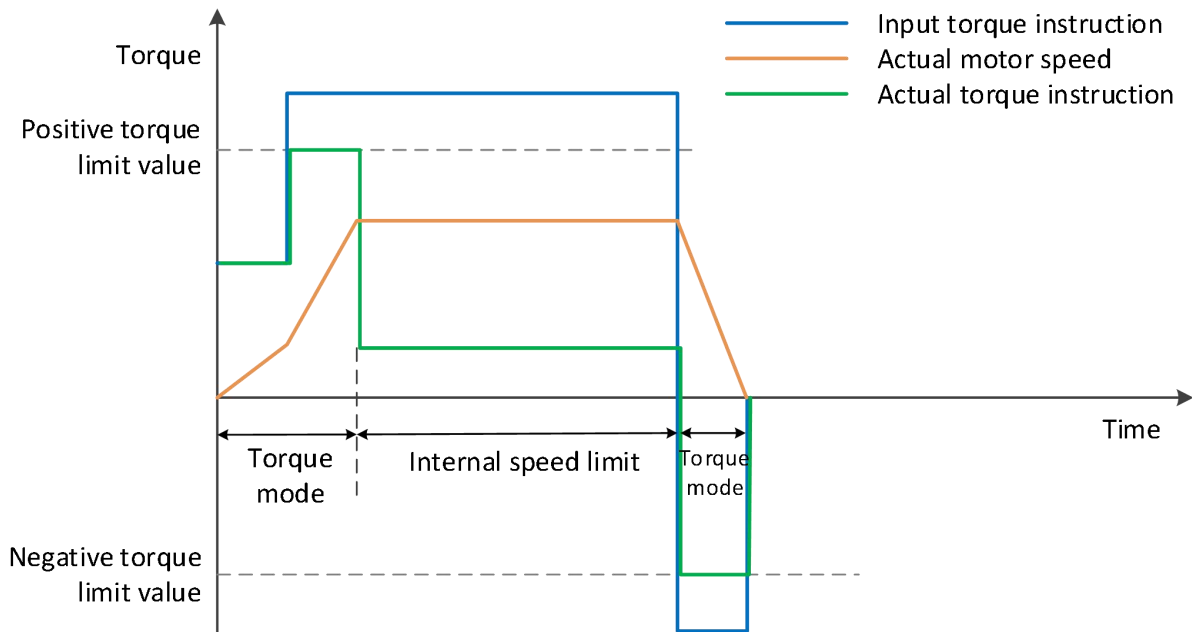

Figure 6-44 Torque instruction limit diagram

(1) Set torque limit source

You need to set the torque limit source by function code P01-14. After the setting, the drive torque instruction will be limited within the torque limit value. When the torque limit value is reached, the motor will operate with the torque limit value as the torque instruction. The torque limit value should be set according to the load operation requirements. If the setting is too small, the motor's acceleration and deceleration capacity may be weakened. During constant torque operation, the actual motor speed cannot reach the required value.

Function code	Name	Setting method	Effective time	Default value	Range	Definition	Unit
P01-14	Torque limit source	Shutdown setting	Effective immediately	0	0 to 1	0: internal value 1: AI_1 analog input (not supported by VD2F and VD2L)	-

1) Torque limit source is internal torque instruction (P01-14=0)

Torque limit source is from inside, you need to set torque limit, and the value is set by function code P01-15 and P01-16.

Function code	Name	Setting method	Effective time	Default value	Range	Definition	Unit
P01-15	Forward torque limit	Operation setting	Effective immediately	3000	0 to 3000	When P01-14 is set to 0, the value of this function code is forward torque limit value	0.1%
P01-16	Reverse torque limit	Operation setting	Effective immediately	3000	0 to 3000	When P01-14 is set to 0, the value of this function code is reverse torque limit value	0.1%

Table 6-48 Torque limit parameter details

2) Torque limit source is external (P01-14=1)

(2) Set torque limit DO signal output

When torque instruction reaches the torque limit value, the drive outputs a torque limit signal (T-LIMIT) for the host computer use. At this time, one DO terminal of the drive should be assigned to function 139 (T-LIMIT, in torque limit), and confirm that the terminal logic is valid.

DO function code	Function name	Function
139	T-LIMIT in torque limit	Output of this signal indicates that the servo motor torque is limited

Table 6-49 DO torque limit function codes

6.4.4 Speed limit in torque mode

In torque mode, if the given torque instruction is too large to exceed the load torque of the mechanical side. This would cause the servo motor to continuously accelerate and overspeed. In order to protect the machinery, the speed of the motor must be limited.

In torque mode, the actual motor speed would be in the limited speed. After the speed limit is reached, the motor runs at a constant speed at the speed limit. The running curves are shown as [Figure 6-45](#) and [Figure 6-46](#).

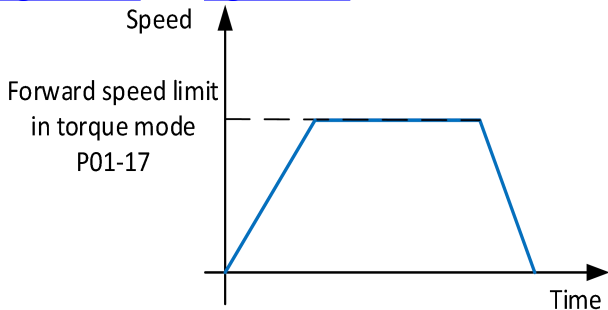

Figure 6-45 Forward running curve

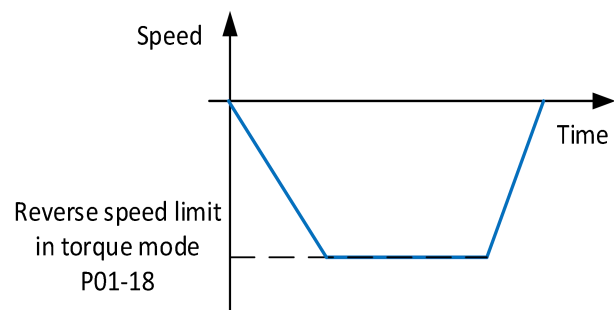

Figure 6-46 Reverse running curve

Function code	Name	Setting method	Effective time	Default value	Range	Definition	Unit
P01-17	Forward torque limit in torque mode	Operation setting	Effective immediately	3000	0 to 5000	Forward torque limit in torque mode	0.1%
P01-18	Reverse torque limit in torque mode	Operation setting	Effective immediately	3000	0 to 5000	Reverse torque limit in torque mode	0.1%

Table 6-50 Speed limit parameters in torque mode

Note:

Function codes P01-17 and P01-18 are only effective in limiting motor speed **in the torque mode**. The speed limit value is set according to load requirements. To set speed limit in speed mode or position mode, please refer to [6.3.3 Speed instruction limit](#).

6.4.5 Torque-related DO output functions

The feedback value of torque instruction is compared with different thresholds, and could output the DO signal for the host computer use. The DO terminal of the servo drive is assigned to different functions and determine the logic to be valid.

Torque arrival

The torque arrival function is used to determine whether the actual torque instruction reaches the set interval. When the actual torque instruction reaches the torque instruction threshold, the servo drive outputs a torque arrival signal (T-COIN) for the host computer use.

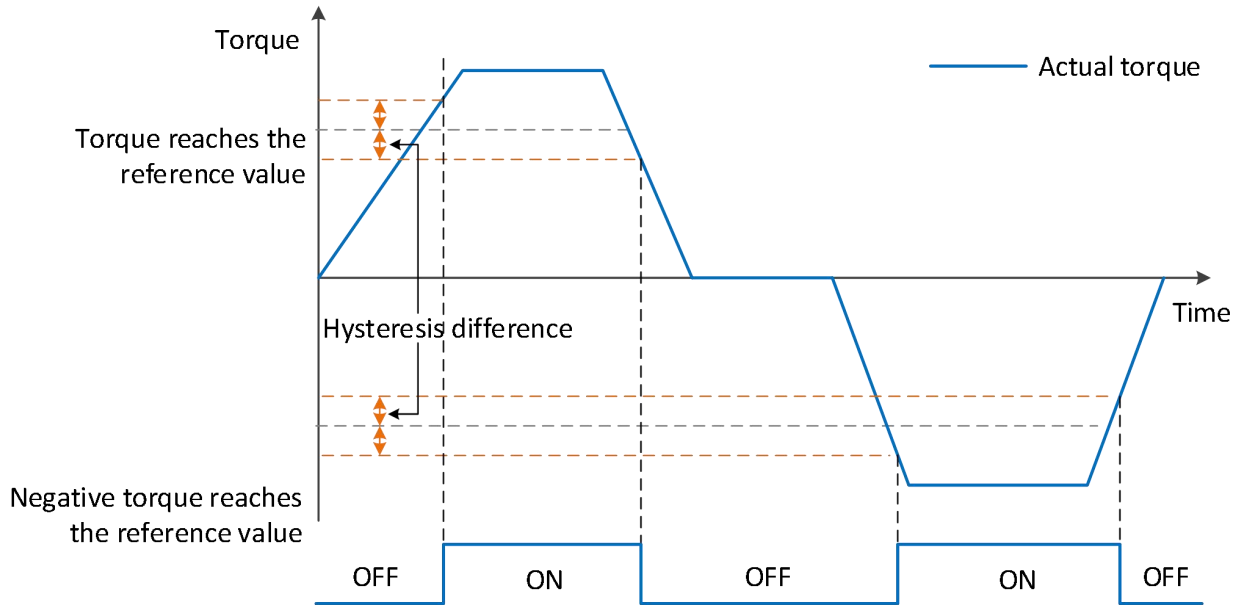

Figure 6-47 Torque arrival output diagram

To use the torque arrival function, a DO terminal of the servo drive should be assigned to function 138 (T-COIN, torque arrival). The function code parameters and related DO function codes are shown in [Table 6-49](#) and [Table 6-50](#).

Function code	Name	Setting method	Effective time	Default value	Range	Definition	Unit
P05-20	Torque arrival threshold	Operation setting	Effective immediately	100	0 to 300	The torque arrival threshold must be used with "Torque arrival hysteresis value": When the actual torque reaches Torque arrival threshold + Torque arrival hysteresis Value, the torque arrival DO is valid; When the actual torque decreases below torque arrival threshold-torque arrival hysteresis value, the torque arrival DO is invalid	%
P05-21	Torque arrival hysteresis	Operation setting	Effective immediately	10	0 to 20	Torque arrival the hysteresis value must be used with Torque arrival threshold	%

Table 6-51 Torque arrival parameters

DO function code	Function name	Function
138	T-COIN torque arrival	Used to determine whether the actual torque instruction has reached the set range

Table 6-52 DO Torque Arrival Function Code

6.5 Mixed control mode

Mixed control mode means that when the servo enable is ON and the status of the servo drive is "run", the mode of the servo drive could be switched between different modes. The VD2 series servo drives have the following 3 mixed control modes:

- Position mode ⇔ Speed mode
- Position mode ⇔ Torque mode
- Speed mode ⇔ Torque mode

Set the function code P00-01 through the software of Wecon "SCTool" or servo drive panel, and the servo drive will run in mixed mode.

Function code	Name	Setting method	Effective time	Default value	Range	Definition	Unit
P00-01	Control mode	Shutdown settings	Shutdown setting	1	1 to 6	1: Position control 2: Speed control 3: Torque control 4: Position/speed mixed control 5: Position/torque mixed control 6: Speed/torque mixed control ⚡ Note: VD2L drive P0-01 setting range: 1-3. Mix mode is not supported!	-

Table 6-53 Mixed control mode parameters

Please set the servo drive parameters in different control modes according to the mechanical structure and indicators. The setting method refer to "[9 Parameters](#)". When function code P00-01=4/5/6 (that is, in mixed mode), a DI terminal of the servo drive needs to be assigned to function 17 (MixModeSel, mixed mode selection), and the DI terminal logic is determined to be valid.

DI function code	Name	Function name	Function		
17	MixModeSel	Mixed mode selection	Used in mixed control mode, when the servo status is "run", set the current control mode of the servo drive		
			P00-01	MixModeSel terminal logic	Control mode
			4	Valid	Speed mode
				invalid	Position mode
			5	Valid	Torque mode
				invalid	Position mode
6	Valid	Torque mode			
	invalid	Speed mode			

Table 6-54 Description of DI function codes in control mode

Note:

In mixed control mode, it is recommended to switch the mode at zero speed or low speed, and the switching process will be smoother.

6.6 Absolute system

6.6.1 Overview

Absolute encoder could detect the position of the servo motor within one turn, and could count the number of turns of the motor. This series of servo drives are equipped with a maximum of 23-bit encoders and could memorize 16-bit multi-turn data, and position, speed, torque control modes could be used. Especially in position control, the absolute value encoder does not need to count, could achieve direct internal high-speed reading and external output, and could significantly reduce the subsequent calculation tasks of the receiving device controller. When the drive is powered off, the encoder uses battery backup data. After power on, the drive uses the encoder's absolute position to calculate the absolute mechanical position, eliminating the need for repeated mechanical origin reset operations.

The absolute value encoder is determined by the mechanical position of the photoelectric code disc, and is not affected by power failure or interference. Each position of the absolute encoder determined by the mechanical position is unique, and no external sensor is required to assist in memorizing position.

6.6.2 Single-turn absolute value system

The single-turn absolute value system is applicable for the equipment load stroke within the single-turn range of the encoder. At this time, the absolute encoder is only as a single-turn system function and does not need to be connected to the battery. The types and information of encoders adapted to VD2 series servo drives are shown as below.

Encoder type	Encoder resolution (bits)	Data range
A1 (single-turn magnetic encoder)	17	0 to 131071

Table 6-55 Single-turn absolute encoder information

The relationship between encoder feedback position and rotating load position is shown in the figure below. (take a 17-bit encoder as an example).

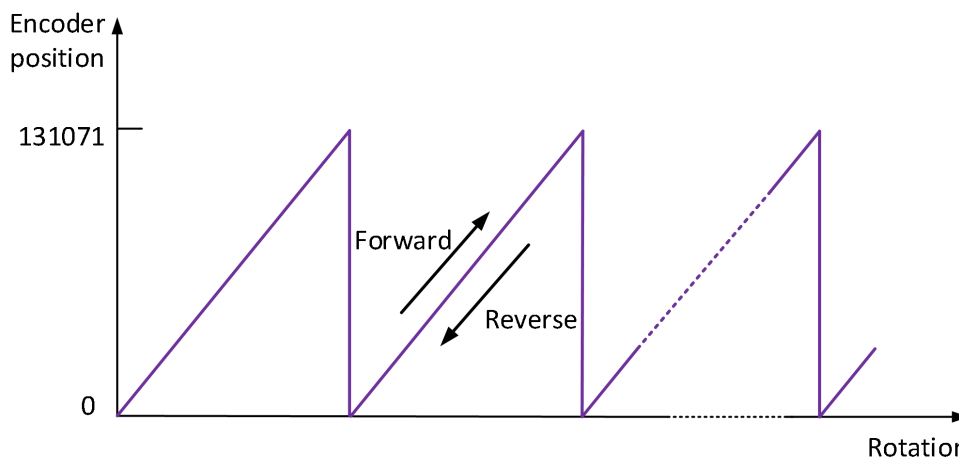

Figure 6-48 Diagram of relationship between encoder feedback position and rotating load position

6.6.3 Multi-turn absolute value system

The encoder adapted to the multi-turn absolute value system is equipped with 16-bit RAM memory. Compared with the single-turn absolute value, it can additionally memorize the number of turns of the 16-bit encoder. The multi-turn absolute encoder is equipped with a battery (the battery is installed on the encoder cable with a battery unit), which can achieve direct internal high-speed readings and external output without the need for external sensors to assist memory positions. The types and information of encoders adapted to VD2 series servo drives are shown as below.

Encoder type	Encoder resolution (bits)	Data range
C1 (multi-turn magnetic encoder)	17	0 to 131071
D2 (multi-turn Optical encoder)	23	0 to 8388607

Table 6-56 Multi-turn absolute encoder information

The relationship between encoder feedback position and rotating load multi-turn is shown in the figure below (take a 23-bit encoder as an example).

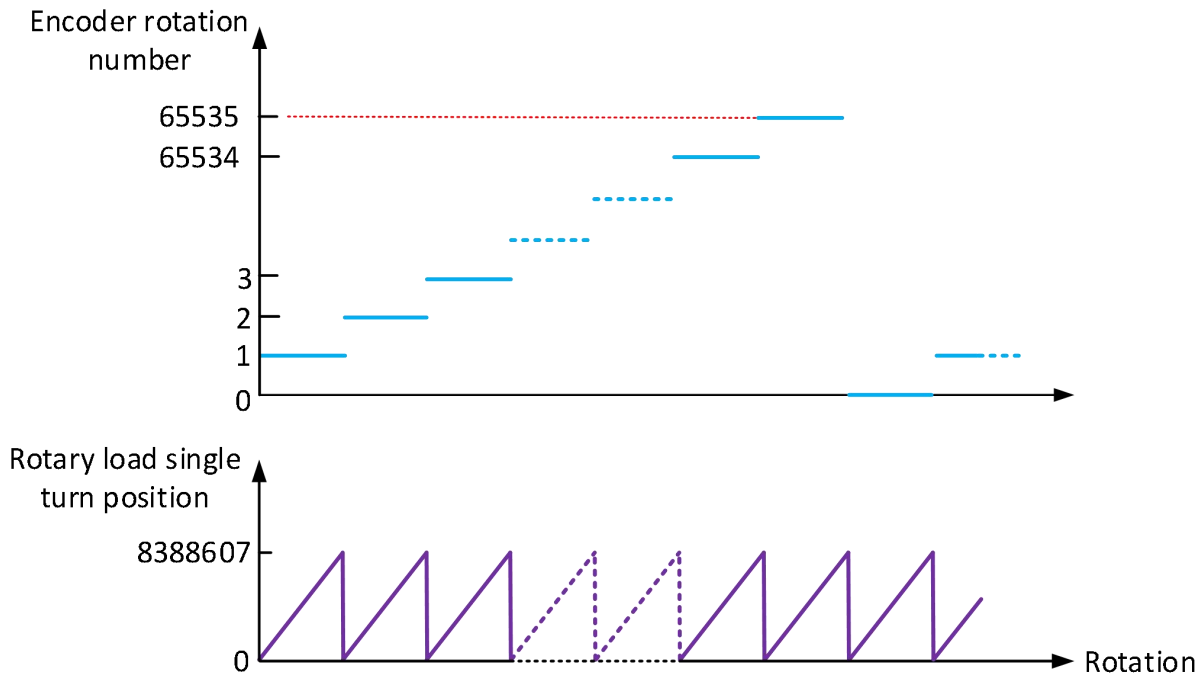

Figure 6-49 The relationship between encoder feedback position and rotating load position

Multi-turn absolute value position U0-56 origin setting (only for multi-turn encoders)

Under the following two working conditions: 1. The current physical position of the motor cannot reach the absolute zero point (U0-56). The value of U0-56 can be calibrated by moving the motor to the target position and setting the offset value of P10-8. 2. Move the motor to a known position on the machine and use this function to determine the position of U0-56.

P10-08 multi-turn absolute encoder origin offset compensation is used in conjunction with U0-56 multi-turn absolute encoder current position. When setting P10-06=1, the value of U0-56 is updated to the value of P10-08 multi-turn absolute value encoder origin offset compensation at the reset time.

Function code	Name	Setting method	Effective time	Default	Range	Definition	Unit
P10-06	Multi-turn absolute encoder reset	Shutdown setting	Effective immediately	0	0 to 1	0: No operation 1: Clear rotation number of multi-turn absolute encoder,	-

						multi-turn absolute encoder current position and encoder fault alarms. Note: After resetting the multi-turn data of the encoder, the encoder absolute position will change suddenly, and the mechanical origin return operation is required.	
P10-08	Multi-turn absolute encoder origin offset compensation	Operation setting	Effective immediately	0	-2147483647 to 2147483646	P10-08 multi-turn absolute encoder origin offset compensation is used in conjunction with U0-56 multi-turn absolute encoder current position. When P10-6 is set to 1, the value of U0-56 is updated to P10-8.	-

6.6.4 Related functions and parameters

(1) Encoder feedback data

The feedback data of the absolute value encoder can be divided into the position within 1 turn of the absolute value encoder and the number of rotations of the absolute value encoder. The related information of the two-feedback data is shown in the table below.

Monitoring number	Category	Name	Unit	Data type
U0-54	Universal	Absolute encoder position within 1 turn	Encoder unit	32-bit
U0-55	Universal	Rotations number of absolute encoder	circle	32-bit
U0-56	Universal	Multi-turn absolute value encoder current position	Instruction unit	32-bit

Table 6-57 Encoder feedback data

(2) Shielded multi-turn absolute encoder battery fault

VD2 series absolute value servo drive provides shielded multi-turn absolute encoder battery fault function to shield under voltage and low-voltage fault. You could set by setting the function code P00-30.

Function code	Name	Setting method	Effective time	Default value	Range	Definition	Unit
P00-30	Shield multi-turn absolute encoder battery fault	Operation setting	Power on again	0	0 to 3	0: Detect multi-turn absolute encoder battery under voltage, and battery low voltage fault 1: [Not recommended] Shield multi-turn absolute motor battery failure alarm. Multi-turn absolute application may cause mechanical fault, only multi-turn absolute encoder motors is used as single-turn absolute 2: [Not recommended] Shield multi-turn absolute value encoder battery under temperature fault, which is very likely to cause mechanical failure. Please use it carefully! 3: [Not recommended] Shield absolute value encoder battery undervoltage and	-

						low voltage failure and multi-turn absolute value encoder battery under temperature failure are very likely to cause mechanical failure, please use it carefully!	
--	--	--	--	--	--	---	--

This function is permitted when a multi-turn absolute encoder motor is used as a single-turn absolute and when it is confirmed that no mechanical failure will occur.

(3) A93 warning solution

Check the encoder communication wire and its placement, reduce the abnormal frequency, and eliminate A93. In this way, the A93 warning problem can be completely solved, and the operation of the motor will not be affected after the A93 warning is released.

Increase the threshold for encoder read-write check exceptions is only suitable as a temporary solution. Eliminate A93 warning by increasing exception threshold. The disadvantage is that the motor may run in an unstable state.

Function code	Name	Setting method	Effective time	Default	Range	Definition	Unit
P00-31	Encoder read-write check abnormal frequency	Operation setting	immediately Effective	20	0 to100	The setting of the alarm threshold for the abnormal frequency of the encoder read-write 0: no alarm Others: When this setting value is exceeded, report A93.	-

Note: Be sure to use the shield multi-turn absolute encoder battery fault function carefully, otherwise it may cause data loss, mechanical failure, or even personal injury or death.

6.6.5 Absolute value system encoder battery

(1) Cautions

Er.40 (Encoder battery failure) will occur when the battery is turned on for the first time, and the function code P10-03 must be set to 1 to clear the encoder fault to operate the absolute value system again.

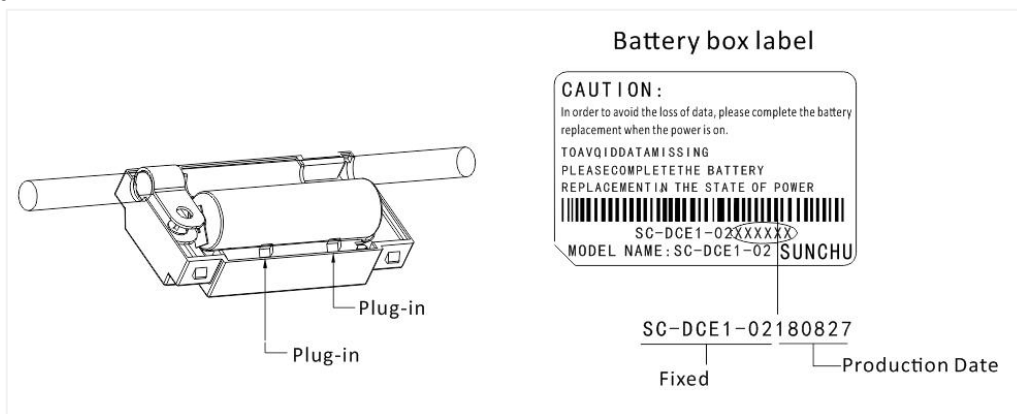

Figure 6-50 the encoder battery box

When it is detected that the battery voltage is less than 3.1V, A-92 (Encoder battery low voltage warning) will occur. Please replace the battery in time.

(2) Replace the battery

Please replace the battery while keeping the servo drive and motor well connected and the power on.

The specific replacement method is as follows:

- ① Step1 Push open the buckles on both ends of the outer cover of the battery compartment and open the outer cover.
- ② Step2 Remove the old battery.
- ③ Step3 Embed the new battery, and the battery plug wire according to the anti-dull port on the battery box for placement.
- ④ Step4 Close the outer cover of the battery box, please be careful not to pinch the connector wiring when closing.

When the servo drive is powered off, if the battery is replaced and powered on again, Er.40 (encoder battery failure) will occur, and the multi-turn data will change suddenly. Please set the function code P10-03 or P10-06 to 1 to clear the encoder fault alarms and perform the origin return function operation again.

Function code	Name	Setting method	Effective time	Default value	Range	Definition	Unit
P10-06	Multi-turn absolute encoder reset	Shutdown setting	Effective immediately	0	0 to 1	0: No operation 1: Clear rotation number of multi-turn absolute encoder, multi-turn absolute encoder current position and encoder fault alarms. 📌 Note: After resetting the multi-turn data of the encoder, the encoder absolute position will change suddenly, and the mechanical origin return operation is required.	-

Table 6-56 Absolute encoder reset enable parameter

(3) Battery selection

Battery selection specification	Item	Value
Nominal Voltage: 3.6V Nominal capacity: 2700mAh	Standard battery voltage (V)	3.6
	Standard cell voltage (V)	3.1
	Battery ambient temperature range	0 to 40
	Battery storage ambient temperature range	-20 to 60

Table 6-58 Absolute value encoder battery information

📌 **Note:**

If the battery is replaced when the servo drive is powered off, the encoder data will be lost. When the servo drive is powered off, please ensure that the maximum speed of motor does not exceed 3000 rpm to ensure that the encoder position information is accurately recorded. Please store the storage device according to the specified ambient temperature, and ensure that the encoder battery has reliable contact and sufficient power, otherwise the encoder position information may be lost.

Correct placement of batteries +, - direction

- Do not disassemble the battery or put the battery into the fire! If the battery is put into the fire or heated, there is a risk of explosion!
- This battery cannot be charged.
- If the battery is left inside the machine after a long period of use or the battery is no longer usable, liquid may leak out, etc. Please replace it as soon as possible! (Recommended to replace every 2 years, you can contact the manufacturer's technical staff for replacement)
- Do not allow the battery to short-circuit or peel the battery skin! Otherwise, there may be a one-time outflow of high current, making the battery's power weakened, or even rupture.

- After the replacement of the battery, please dispose of it according to local laws and regulations.

6.7 Other functions

6.7.1 VDI

VDI (Virtual Digital Signal Input Port) is similar to hardware DI terminal. The DI function could also be assigned for use.

Note: If multiple VDI terminals are configured with the same non-zero DI function, servo drive will occur an error “A-89” (DI port configuration is duplicate).

Take the VDI_1 terminal assignment forward drive prohibition (03-POT) as an example, and the use steps of VDI are as the figure below.

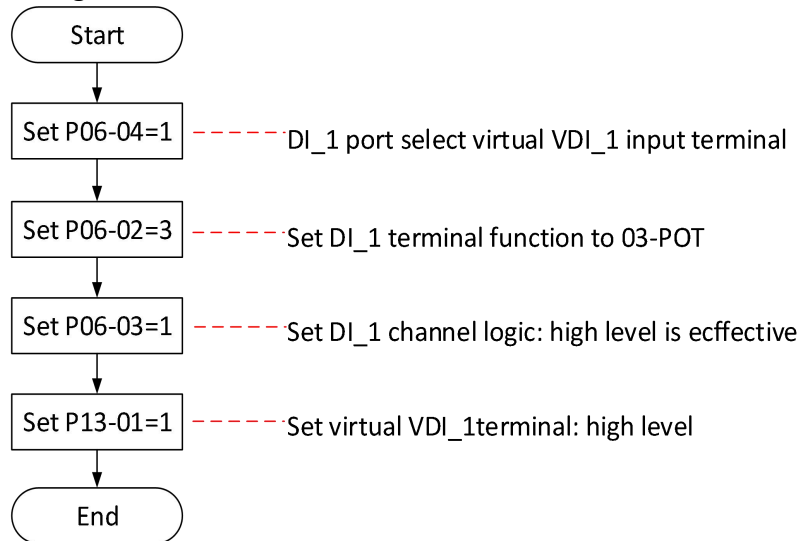

Figure 6-51 VDI_1 setting steps

Function code	Name	Setting method	Effective time	Default value	Range	Definition	Unit
P13-1	Virtual VDI_1 input value	Operation setting	Effective immediately	0	0 to 1	When P06-04 is set to 1, DI_1 channel logic is control by this function code. VDI_1 input level: 0: low level 1: high level	-
P13-2	Virtual VDI_2 input value	Operation setting	Effective immediately	0	0 to 1	When P06-07 is set to 1, DI_2 channel logic is control by this function code. VDI_2 input level: 0: low level 1: high level	-
P13-3	Virtual VDI_3 input value	Operation setting	Effective immediately	0	0 to 1	When P06-10 is set to 1, DI_3 channel logic is control by this function code. VDI_3 input level: 0: low level 1: high level	-
P13-4	Virtual VDI_4 input value	Operation setting	Effective immediately	0	0 to 1	When P06-13 is set to 1, DI_4 channel logic is control by this function code. VDI_4 input level: 0: low level 1: high level	-

P13-05★	Virtual VDI_5 input value	Operation setting	Effective immediately	0	0 to 1	When P06-16 is set to 1, DI_5 channel logic is control by this function code. VDI_5 input level: 0: low level 1: high level	-
P13-06★	Virtual VDI_6 input value	Operation setting	Effective immediately	0	0 to 1	When P06-19 is set to 1, DI_6 channel logic is control by this function code. VDI_6 input level: 0: low level 1: high level	-
P13-07★	Virtual VDI_7 input value	Operation setting	Effective immediately	0	0 to 1	When P06-22 is set to 1, DI_7 channel logic is control by this function code. VDI_7 input level: 0: low level 1: high level	-
P13-08★	Virtual VDI_8 input value	Operation setting	Effective immediately	0	0 to 1	When P06-25 is set to 1, DI_8 channel logic is control by this function code. VDI_8 input level: 0: low level 1: high level	-

Table 6-59 Virtual VDI parameters

Note: “★” means VD2F and V D2L servo drive does not support the function code.

6.7.2 Port filtering time

VD2A and VD2B servo drives have 8 hardware DI terminals (DI_1 to DI_8) , and VD2F servo drive has 4 hardware DI terminals (DI_1 to DI_4) . All the DI terminals are normal terminals.

Setting value	DI channel logic selection	Illustration
0	Active high level	
1	Active low level	

Table 6-60 DI terminal channel logic selection

6.7.3 VDO

In addition to being an internal hardware output port, DO terminal is also used as a communication VDO. The communication control DO function could help you to achieve communication control DO output on the servo drive.

Take the DO_2 terminal as communication VDO, and the use steps of VDI are as the figure below.

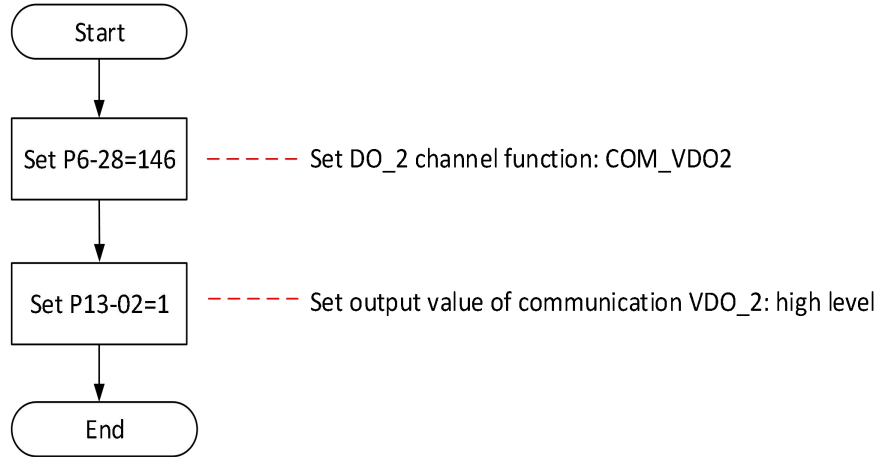

Figure 6-52 VDO_2 setting steps

Function code	Name	Setting method	Effective time	Default value	Range	Definition	Unit
P13-11	Communication VDO_1 output value	Operation setting	Effective immediately	0	0 to 1	VDO_1 output level: 0: low level 1: high level	-
P13-12	Communication VDO_2 output value	Operation setting	Effective immediately	0	0 to 1	VDO_2 output level: 0: low level 1: high level	-
P13-13	Communication VDO_3 output value	Operation setting	Effective immediately	0	0 to 1	VDO_3 output level: 0: low level 1: high level	-
P13-14	Communication VDO_4 output value	Operation setting	Effective immediately	0	0 to 1	VDO_4 output level: 0: low level 1: high level	-

Table 6-61 Communication control DO function parameters

DO function number	Function name	Function
145	COM_VDO1 communication VDO1 output	Use communication VDO
146	COM_VDO1 communication VDO2 output	Use communication VDO
147	COM_VDO1 communication VDO3 output	Use communication VDO
148	COM_VDO1 communication VDO4output	Use communication VDO

Table 6-62 VDO function number

Note:

You are advised to configure function codes for DO terminals in sequence to avoid errors during DO signal observation

If multiple DO terminals are configured with the same non-128 DI function, servo drive will occur an error "A-90" (DO port configuration is duplicate).

6.7.4 Motor overload protection

VD2 Series absolute encoder (VD2SA) servo drive provides motor overload protection to prevent motor burning due to high temperature. By setting function code P10-04 to modify motor overload alarm (A-82) and motor overload protection fault time (Er.34). The default value of P10-04 is 100%.

Function code	Name	Setting method	Effective time	Default value	Range	Definition	Unit
P10-04	motor overload protection time coefficient	Operation setting	Effective immediately	100	0 to 800	According to the heating condition of the motor, the value could be modified to make the overload protection time float up and down in the reference value. 50 corresponds to 50%, that is, the time is reduced by half. 300 corresponds to 300%, that is, the time extended to 3 times. When the value is set to 0, the overload protection fault detection function is disabled	%

In the following cases, it could be modified according to the actual heat generation of the motor

- ① The motor works in a place with high ambient temperature
- ② The motor runs in cycle circulates, and the single running cycle is short and the acceleration and deceleration is frequent.

7. Adjustments

7.1 Overview

The servo drive needs to make the motor faithfully operate in accordance with the instructions issued by the upper controller without delay as much as possible. In order to make the motor action closer to the instruction and maximize the mechanical performance, gain adjustment is required. The process of gain adjustment is shown in figure 7-1.

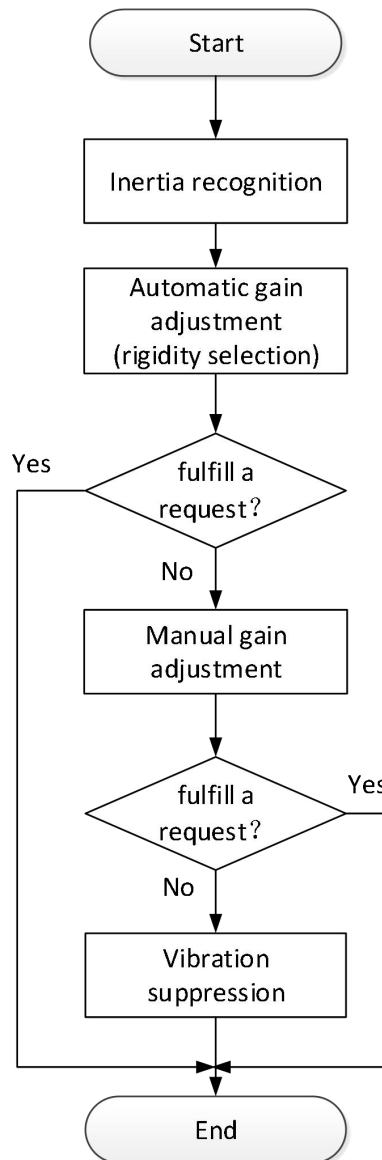

Figure 7-1 Gain adjustment process

The servo gain is composed of multiple sets of parameters such as position loop, speed loop, filter, load inertia ratio, etc., and they affect each other. In the process of setting the servo gain, the balance between the setting values of each parameter must be considered.

Note: Before adjusting the gain, it is recommended to perform a jog trial run first to ensure that the servo motor can operate normally!

The gain adjustment process description is shown in the table below.

Gain adjustment process		Function	Detailed chapter
1	Online inertia recognition	Use the host computer debugging platform software matched with the drive to automatically identify the load inertia ratio. With its own inertia recognition function, the drive automatically calculates the load inertia ratio.	7.2
2	Automatic gain adjustment	On the premise of setting the inertia ratio correctly, the drive automatically adjusts a set of matching gain parameters.	7.3.1
3	Manual gain adjustment	Basic gain	On the basis of automatic gain adjustment, if the expected effect is not achieved, manually fine-tune the gain to optimize the effect. 7.3.2
		Feedforward gain	The feedforward function is enabled to improve the followability. 7.3.3
		Model tracking control	Enable Model tracking control, shortening the responding time and improving followability. 7.3.4
4	Vibration suppression	Mechanical resonance	The notch filter function is enabled to suppress mechanical resonance. 7.4.1
		Low frequency vibration suppression	Enable low frequency vibration suppression 7.4.3
		Type A vibration suppression	Enable type A vibration suppression 7.4.4

Table 7-1 Description of gain adjustment process

7.2 Inertia recognition

Load inertia ratio P03-01 refers to:

$$\text{Load inertia ratio} = \frac{\text{Total moment of inertia of mechanical load}}{\text{Motor's moment of inertia}}$$

The load inertia ratio is an important parameter of the servo system, and setting of the load inertia ratio correctly helps to quickly complete the debugging. The load inertia ratio could be set manually, and online load inertia recognition could be performed through the host computer debugging software.



⚠ Before performing online load inertia recognition, the following conditions should be met:

The maximum speed of the motor should be greater than 300rpm;

The actual load inertia ratio is between 0.00 and 100.00;

The load torque is relatively stable, and the load cannot change drastically during the measurement process;

The backlash of the load transmission mechanism is within a certain range;

⚠ The motor's runnable stroke should meet two requirements:

There is a movable stroke of more than 1 turn in both forward and reverse directions between the mechanical limit switches.

Before performing online inertia recognition, please make sure that the limit switch has been installed on the machine, and that the motor has a movable stroke of more than 1 turn each in the forward and reverse directions to prevent overtravel during the inertia recognition process and cause accidents.

Meet the requirement of inertia recognition turns P03-05.

Make sure that the motor's runnable stroke at the stop position is greater than the set value of the

number of inertia recognition circles P03-05, otherwise the maximum speed of inertia recognition P03-06 should be appropriately reduced.

During the automatic load inertia recognition process, if vibration occurs, the load inertia recognition should be stopped immediately.

The related function codes are shown in the table below.

Function code	Name	Setting method	Effective time	Default value	Range	Definition	Unit
P03-01	Load inertia ratio	Operation setting	Effective immediately	300	100 to 10000	Set load inertia ratio, 0.00 to 100.00 times	0.01
P03-05	Inertia recognition turns	Shutdown setting	Effective immediately	2	1 to 20	Offline load inertia recognition process, motor rotation number setting	circle
P03-06	Inertia recognition maximum speed	Shutdown setting	Effective immediately	1000	300 to 2000	Set the allowable maximum motor speed instruction in offline inertia recognition mode. The faster the speed during inertia recognition, the more accurate the recognition result will be. Usually, you can keep the default value.	rpm
P03-07	Parameter recognition rotation direction	Shutdown setting	Effective immediately	0	0 to 2	0: Forward and reverse reciprocating rotation 1: Forward one-way rotation 2: Reverse one-way rotation	-

Table 7-2 Related parameters of gain adjustment

7.3 Gain adjustment

In order to optimize the responsiveness of the servo drive, the servo gain set in the servo drive needs to be adjusted. Servo gain needs to set multiple parameter combinations, which will affect each other. Therefore, the adjustment of servo gain must consider the relationship between each parameter.

Under normal circumstances, high-rigidity machinery can improve the response performance by increasing the servo gain. But for machines with lower rigidity, when the servo gain is increased, vibration may occur, and then affects the increase in gain. Therefore, selecting appropriate servo gain parameters can achieve higher response and stable performance.

The servo supports automatic gain adjustment and manual gain adjustment. It is recommended to use automatic gain adjustment first.

7.3.1 Automatic gain adjustment

Automatic gain adjustment means that through the rigidity level selection function P03-02, the servo drive will automatically generate a set of matching gain parameters to meet the requirements of rapidity and stability.

The rigidity of the servo refers to the ability of the motor rotor to resist load inertia, that is, the self-locking ability of the motor rotor. The stronger the servo rigidity, the larger the corresponding position loop gain and speed loop gain, and the faster the response speed of the system.



CAUTION

Before adjusting the rigidity grade, set the appropriate load inertia ratio P03-01 correctly.

VD2L drive does not support automatic gain adjustment!

The value range of the rigidity grade is between 0 and 31. Grade 0 corresponds to the weakest rigidity and minimum gain, and grade 31 corresponds to the strongest rigidity and maximum gain. According to different load types, the values in the table below are for reference.

Rigidity grade	Load mechanism type
Grade 4 to 8	Some large machinery
Grade 8 to 15	Low rigidity applications such as belts
Grade 15 to 20	High rigidity applications such as ball screw and direct connection

Table 7-3 Experience reference of rigidity grade

When the function code P03-03 is set to 0, the gain parameters are stored in the first gain by modifying the rigidity grade.

When debugging with the host computer debugging software, automatic rigidity level measurement can be carried out, which is used to select a set of appropriate rigidity grades as operating parameters. The operation steps are as follows:

- ① Confirm that the servo is in the ready state, the panel displays "rdy", and the communication line is connected;
- ② Open the Wecon SCTool, go to the "Debugging" interface, enter the trial run interface, set the corresponding parameters, and click "Servo on";
- ③ Click the "Forward rotation" or "Reverse rotation" button to confirm the travel range of the servo operation;
- ④ After the "Identify" of inertia recognition lights up, click "Identify" to perform inertia recognition, and the load inertia can be measured.
- ⑤ After the inertia recognition test is completed, click "Save inertia value";
- ⑥ Click "Next" button to go to the parameter adjustment interface, and click "Parameter measurement".
- ⑦ After the parameter measurement is completed, the Wecon SCTool will pop up a confirmation window for parameter writing and saving.

CAUTION

There may be a short mechanical whistling sound during the test. Generally, the servo will automatically stop the test. If it does not stop automatically or in other abnormal situations, you can click the "Servo Off" button on the interface to turn off the servo, or power off the machine!

For the detailed operation of the host computer debugging software, please refer to "Wecon Servo Debugging Platform User Manual".

Function code	Name	Setting method	Effective time	Default value	Range	Definition	Unit
P03-03	Self-adjusting mode selection	Operation setting	Effective immediately	0	0 to 2	0: Rigidity grade self-adjusting mode. Position loop gain, speed loop gain, speed loop integral time constant, torque filter parameter settings are automatically adjusted according to the rigidity grade setting. 1: Manual setting; you need to manually set the position loop gain, speed loop gain, speed loop integral time constant, torque filter parameter setting	-

						2: Online automatic parameter self-adjusting mode (Not implemented yet)	
--	--	--	--	--	--	---	--

Table 7-4 Details of self-adjusting mode selection parameters

7.3.2 Manual gain adjustment

When the servo automatic gain adjustment fails to achieve the desired result, you can manually fine-tune the gain to achieve better results.

The servo system consists of three control loops, from the outside to the inside are the position loop, the speed loop and the current loop. The basic control block diagram is shown as below.

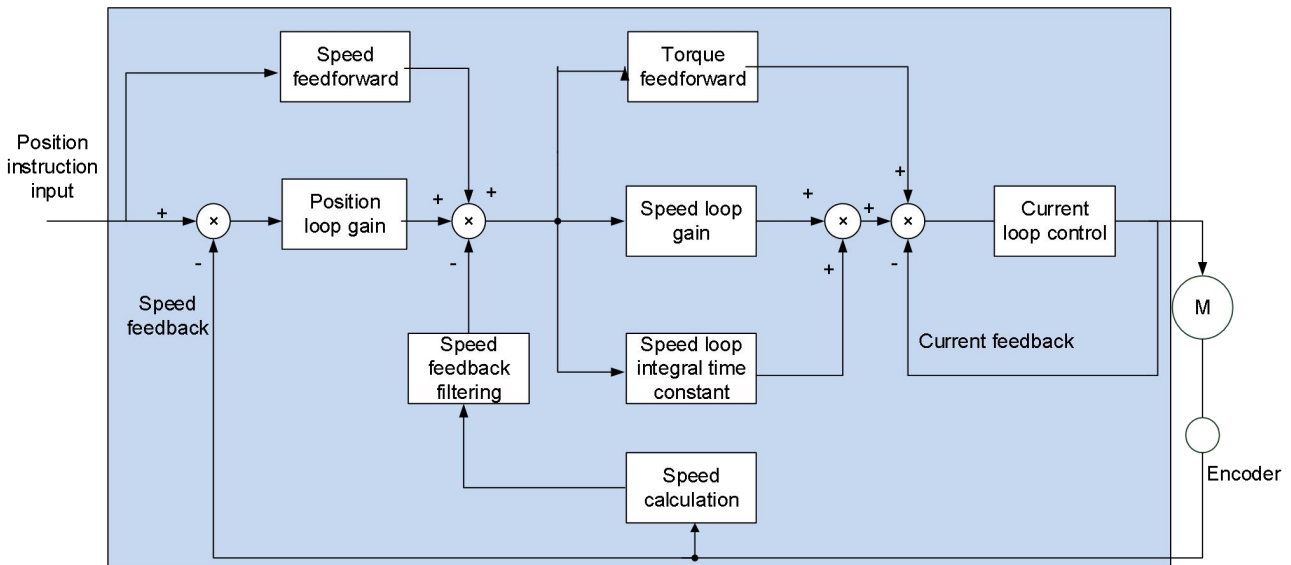

Figure 7-2 Basic block diagram of servo loop gain

The more the inner loop is, the higher the responsiveness is required. Failure to comply with this principle may lead to system instability!

The default current loop gain of the servo drive has ensured sufficient responsiveness. Generally, no adjustment is required. Only the position loop gain, speed loop gain and other auxiliary gains need to be adjusted.

This servo drive has two sets of gain parameters for position loop and speed loop. The user can switch the two sets of gain parameters according to the setting value of P02-07 the 2nd gain switching mode. The parameters are below.

Function code	Name
P02-01	The 1st position loop gain
P02-02	The 1st speed loop gain
P02-03	The 1st speed loop integral time constant
P02-04	The 2nd position loop gain
P02-05	The 2nd speed loop gain
P02-06	The 2nd speed loop integral time constant
P04-04	Torque filter time constant

(1) Speed loop gain

In the case of no vibration or noise in the mechanical system, the larger the speed loop gain setting value, the better the response of servo system and the better the speed followability. When noise occurs in the system, reduce the speed loop gain. The related function codes are shown as below.

Function code	Name	Setting method	Effective time	Default value	Range	Definition	Unit
P02-02	1st speed loop gain	Operation setting	Effective immediately	65	0 to 35000	Set speed loop proportional gain to determine the responsiveness of speed loop.	0.1Hz
P02-05	2nd speed loop gain	Operation setting	Effective immediately	65	0 to 35000	Set speed loop proportional gain to determine the responsiveness of speed loop.	0.1Hz

Table 7-5 Speed loop gain parameters

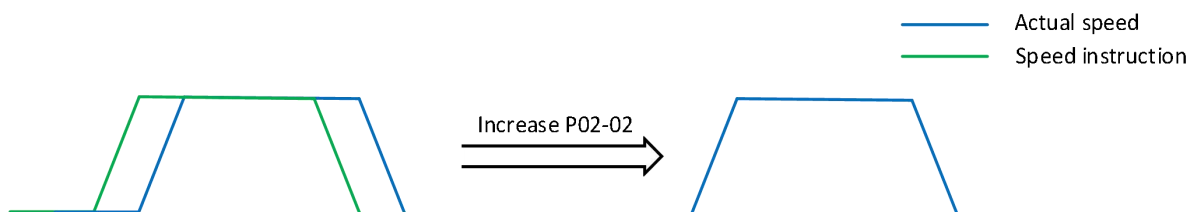

Figure 7-3 Speed loop gain effect illustration

(2) Speed loop integral time constant

The speed loop integral time constant is used to eliminate the speed loop deviation. Decreasing the integral time constant of the speed loop can increase the speed of the speed following. If the set value is too small, it will easily cause speed overshoot or vibration. When the time constant is set too large, the integral action will be weakened, resulting in a deviation of the speed loop. Related function codes are shown as below.

Function code	Name	Setting method	Effective time	Default value	Range	Definition	Unit
P02-03	1st speed loop integral time constant	Operation setting	Effective immediately	1000	100 to 65535	Set the speed loop integral constant. The smaller the set value, the stronger the integral effect.	0.1 ms
P02-06	2nd speed loop integral time constant	Operation setting	Effective immediately	1000	0 to 65535	Set the speed loop integral constant. The smaller the set value, the stronger the integral effect.	0.1 ms

Table 7-6 Speed loop integral time constant parameters

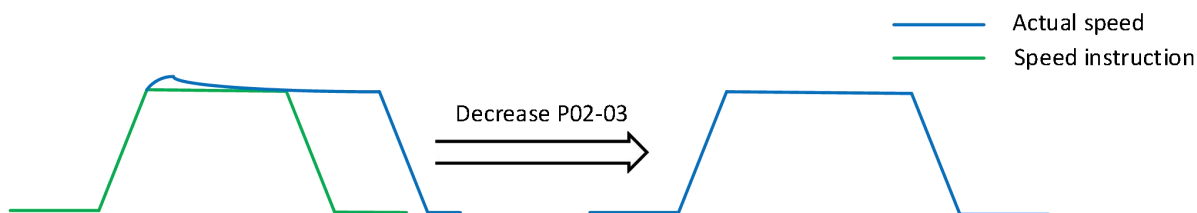

Figure 7-4 Speed loop integral time constant effect illustration

(3) Position loop gain

Determine the highest frequency of the position instruction that the position loop can follow the change. Increasing this parameter can speed up the positioning time and improve the ability of the motor to resist external disturbances when the motor is stationary. However, if the setting value is too large, the system may be unstable and oscillate. The related function codes are shown as below.

Function code	Name	Setting method	Effective time	Default value	Range	Definition	Unit
---------------	------	----------------	----------------	---------------	-------	------------	------

P02-01	1st position loop gain	Operation setting	Effective immediately	400	0 to 6200	Set position loop proportional gain to determine the responsiveness of position control system.	0.1Hz
P02-04	2nd position loop gain	Operation setting	Effective immediately	35	0 to 6200	Set position loop proportional gain to determine the responsiveness of position control system.	0.1Hz

Table 7-7 Position loop gain parameters

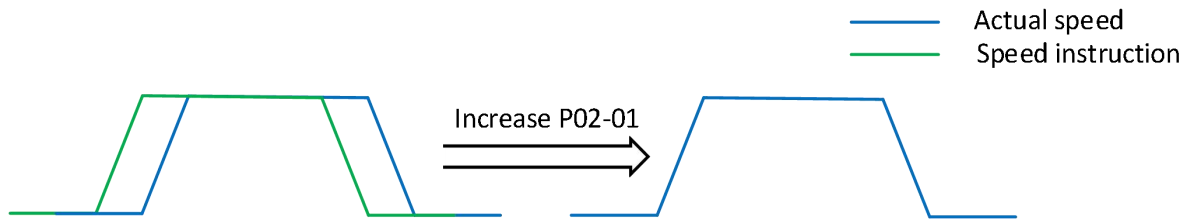

Figure 7-5 Position loop gain effect illustration

(4) Torque instruction filter time

Selecting an appropriate torque filter time constant could suppress mechanical resonance. The larger the value of this parameter, the stronger the suppression ability. If the setting value is too large, it will decrease the current loop response frequency and cause needle movement. The related function codes are shown as below.

Function code	Name	Setting method	Effective time	Default value	Range	Definition	Unit
P04-04	Torque filter time constant	Operation setting	Effective immediately	50	10 to 2500	This parameter is automatically set when "self-adjustment mode selection" is selected as 1 or 2	0.01 ms

Table 7-8 Details of torque filter time constant parameters

7.3.3 Feedforward gain

Speed feedforward could be used in position control mode and full closed-loop function. It could improve the response to the speed instruction and reduce the position deviation with fixed speed. Speed feedforward parameters are shown in [Table 7-9](#). Torque feedforward parameters are shown in [Table 7-10](#).

Function code	Name	Adjustment description
P02-09	Speed feedforward gain	When the speed feedforward filter is set to 50 (0.5 ms), gradually increase the speed feedforward gain, and the speed feedforward will take effect. The position deviation during operation at a certain speed will be reduced according to the value of speed feedforward gain as the formula below. Position deviation (instruction unit) = instruction speed [instruction unit/s] ÷ position loop gain [1/s] × (100 – speed feedforward gain [%]) ÷ 100
P02-10	Speed feedforward filtering time constant	

Table 7-9 Speed feedforward parameters

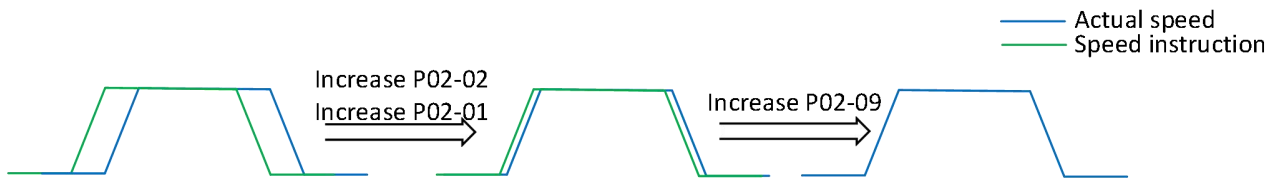

Figure 7-6 Speed feedforward parameters effect illustration

Function code	Name	Adjustment description
P02-11	Torque feedforward gain	Increase the torque feedforward gain because the position deviation can be close to 0 during certain acceleration and deceleration. Under the ideal condition of external disturbance torque not operating, when driving in the trapezoidal speed model, the position deviation can be close to 0 in the entire action interval. In fact, there must be external disturbance torque, so the position deviation cannot be 0. In addition, like the speed feedforward, although the larger the constant of the torque feedforward filter, the smaller the action sound, but the greater the position deviation of the acceleration change point.
P02-12	Torque feedforward filtering time constant	

Table 7-10 Torque feedforward parameters

7.3.4 Model Tracking Control Function

Model tracking control is suitable for position control mode, which adds a model loop outside the three loops. In the model loop, new position commands, speed feedforward and torque feedforward and other control quantities are generated according to the user's response requirements to the system and the ideal motor control model. Applying these control quantities to the actual control loop can significantly improve the response performance and positioning performance of the position control, the design block diagram is as follows:

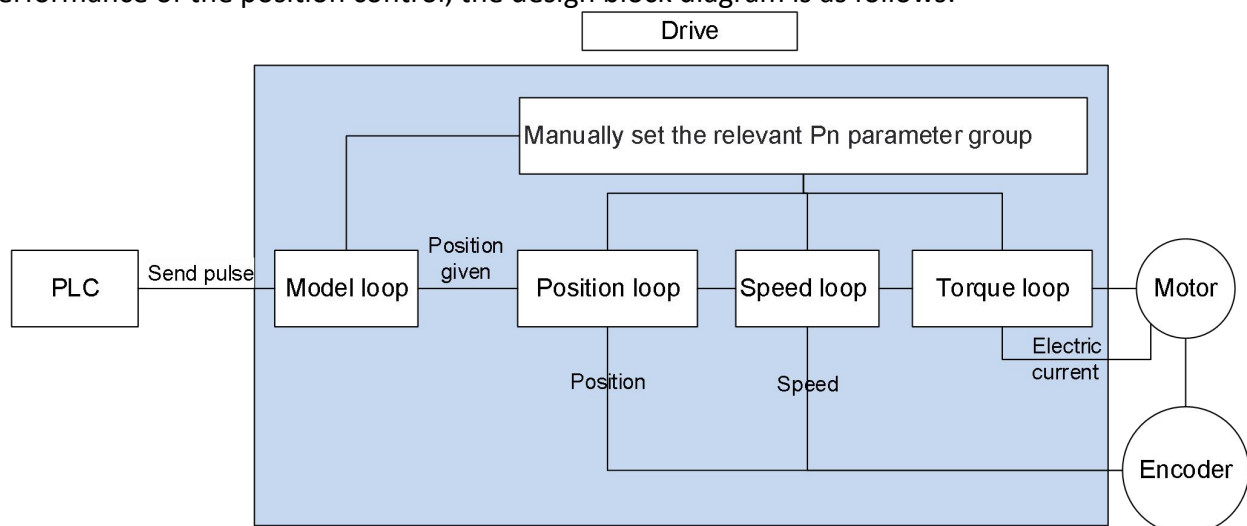

Figure 7-7 Block Diagram of Model Tracking Control Design

The usage method and conditions of model tracking control:

1. Correctly set the inertia ratio of the system P3-1, which can be obtained by monitoring the real-time load inertia ratio of U0-20.
2. Set the load rigidity level P3-2, set an appropriate value, it does not need to set a high rigidity level (recommended value 17~21 under rigid load).
3. Set P2-20=1 to enable the function of model tracking control.

4. Adjust the P2-21 model tracking control gain from small to large, and gradually increase in steps of 1000 until the responsiveness of the system meets the actual demand. The responsiveness of the system is mainly determined by this parameter.

5. After the responsiveness meets the requirements, user can adjust the parameters appropriately to increase the load rigidity level P3-2.

Note: Model tracking control is only available in position mode, and cannot be used in other modes.

Function code	Name	Setting method	Effective time	Default	Range	Definition	Unit
P2-20	Model tracking control function	Shutdown setting	Effective immediately	0	0 to 1	When the function code is set to 1, enable the model tracking control function.	
P2-21	Model tracking control gain	Shutdown setting	Effective immediately	1000	200 to 20000	Increasing the model tracking control gain can improve the position response performance of the model loop. If the gain is too high, it may cause overshoot behavior. The gain compensation affects the damping ratio of the model loop, and the damping ratio becomes larger as the gain compensation becomes larger.	0.1/s
P2-22	Model tracking control gain compensation	Shutdown setting	Effective immediately	1000	500 to 2000		0.10%

Function code	Name	Setting method	Effective time	Default	Range	Definition	Unit
P2-23	Model tracking control forward rotation bias	Operation setting	Effective immediately	1000	0 to 10000	Torque feedforward size in the positive and reverse direction under model tracking control	0.10%
P2-24	Model tracking control reverses rotation bias	Operation setting	Effective immediately	1000	0 to 10000		0.10%

P2-25	Model tracking control speed feedforward compensation	Operation setting	Effective immediately	1000	0 to 10000	The size of the speed feedforward under model tracking control	0.10%
-------	---	-------------------	-----------------------	------	------------	--	-------

Please refer to the following for an example of the procedure of adjusting servo gain.

Step	Content
1	Please try to set the correct load inertia ratio parameter P3-1.
2	If the automatic adjustment mode is used (P3-3 is set to 0), please set the basic rigidity level parameter P3-2. If in manual adjustment mode (P3-3 is set to 1), please set the gain P2-1~P2-3 related to the position loop and speed loop and the torque filter time constant P4-4. The setting principle is mainly no vibration and overshoot.
3	Turn on the model tracking function, set P2-20 to 1.
4	Increase the model tracking gain P2-21 within the range of no overshoot and vibration occurring.
5	If the rigidity level of step 2 is set relatively low, user can properly increase the rigidity level P3-2.
6	When overshoot occurs, or the responses of forward rotation and reverse rotation are different, user can fine-tune through model tracking control forward bias P2-23, model tracking control reverse bias P2-24, model tracking control speed feedforward compensation P2-25.

7.3.5 Gain switching

Gain switching function:

- Switch to a lower gain in the motor stationary (servo enabled) state to suppress vibration;
- Switch to a higher gain in the motor stationary state to shorten the positioning time;
- Switch to a higher gain in the motor running state to get better command tracking performance;
- Switch different gain settings by external signals depending on the load connected.

(1) Gain switching parameter setting

① When P02-07=0

Fixed use of the first gain (using P02-01~P02-03), and the switching of P/PI (proportional/proportional integral) control could be realized through DI function 10 (GAIN-SEL, gain switching).

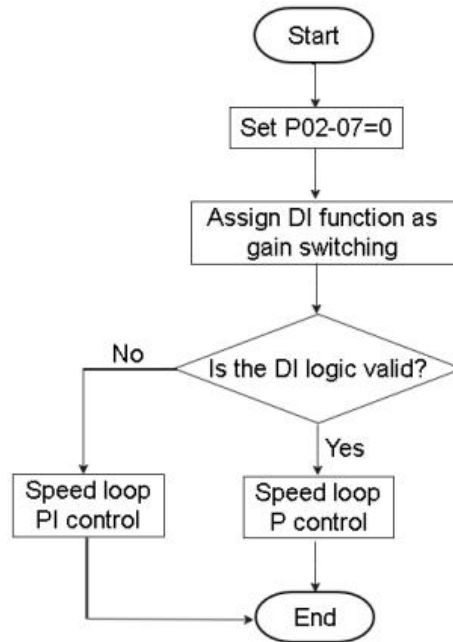

Figure 7-8 Flow chart of gain switching when P02-07=0

Figure 7-8

② When P02-07=1

The switching conditions can be set through parameter P02-08 to realize switching between the first gain (P02-01~P02-03) and the second gain (P02-04~P02-06).

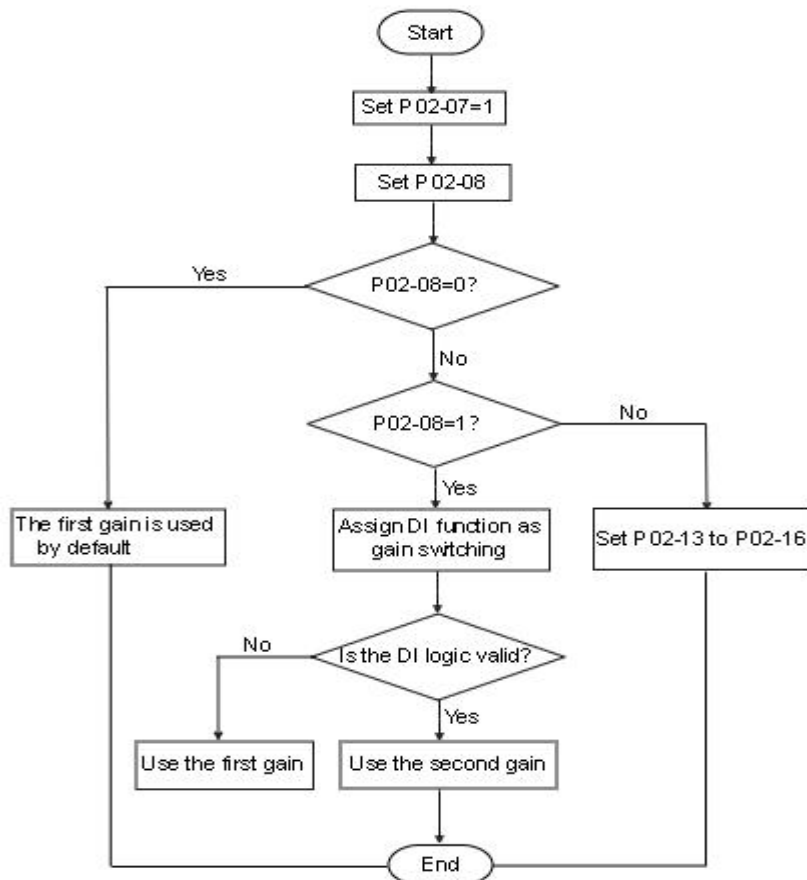

Figure 7-9 Flow chart of gain switching when P02-07=1

P02-08	Content	Diagram
0	Fixed use of the first gain	--
1	Switching with DI	--
2	Large torque command	<p>The diagram shows two waveforms: Actual speed (blue) and Torque command (red). The torque command has a large peak. The actual speed follows the torque command with a delay. Labels include 'Switching delay', 'Switching grade', and 'First gain', 'Second gain', 'First gain'.</p>
3	Large actual torque	<p>The diagram shows the Actual speed (blue) waveform. Labels include 'Switching grade', 'First gain', 'Second gain', 'First gain'.</p>
4	Large speed command	<p>The diagram shows the Speed command (blue) waveform. Labels include 'Switching grade', 'Switching delay', 'First gain', 'Second gain', 'First gain'.</p>

(Continued on next page)

P02-08	Content	Diagram
5	Fast actual speed	
6	Speed command change rate is large	
7	Large position deviation	
8	Position command	

(Continued on next page)

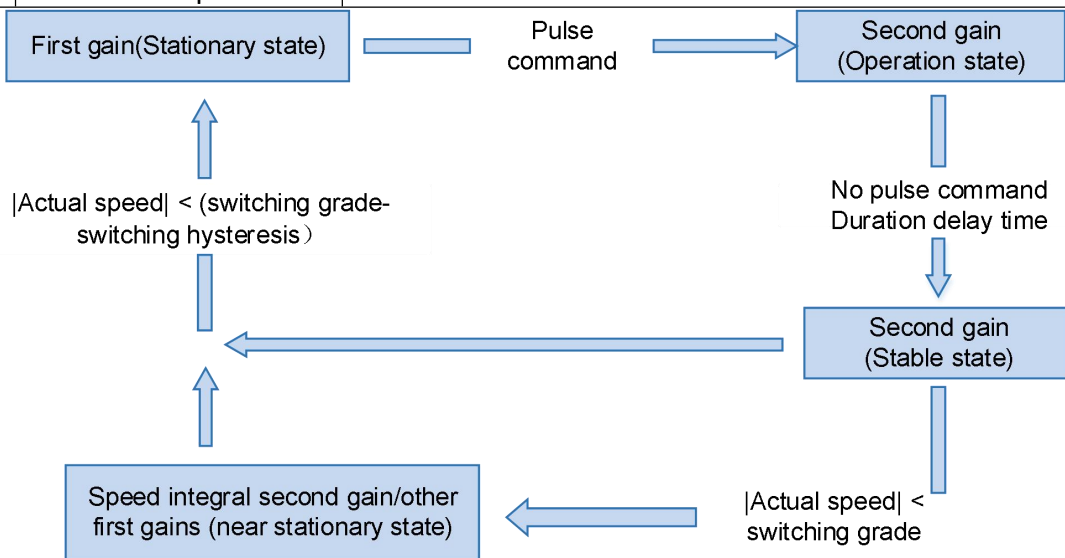
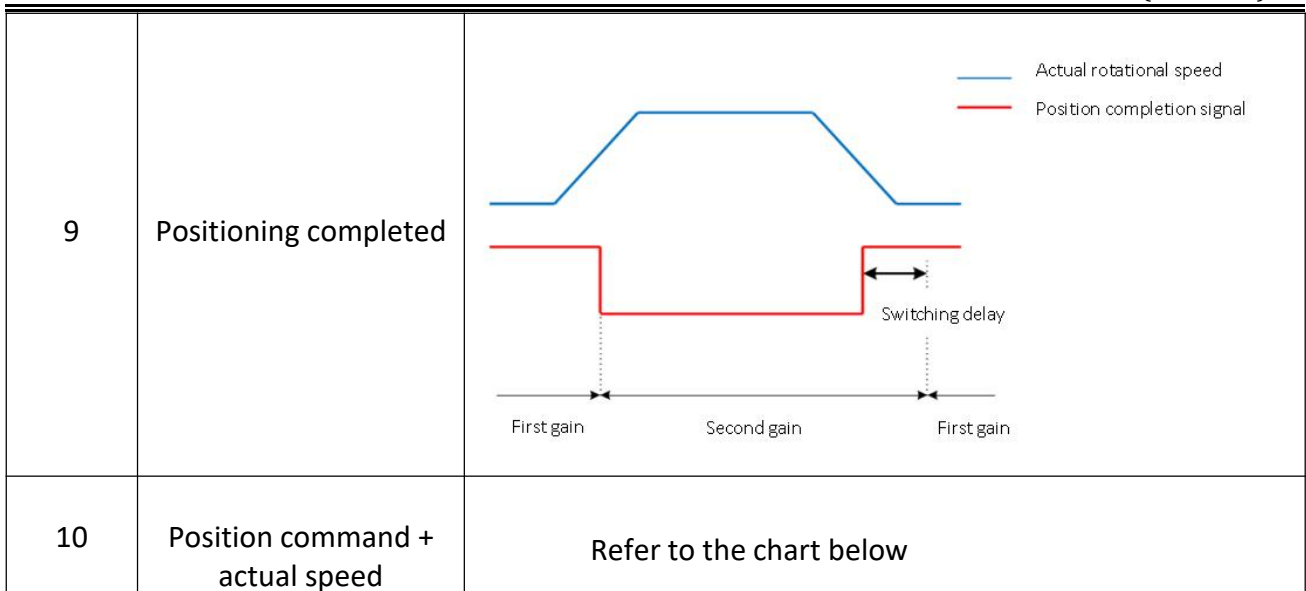

Figure 7-10 P02-08=10 Position command + actual speed gain description

(2) Description of related parameters

P02-07	Parameter name	Setting method	Effective time	Default	Set range	Application category	Unit
	The second gain switching mode	Operation setting	Effective immediately	1	0 to 1	Gain control	

Set the switching mode of the second gain.

Setting value	Function
0	The first gain is used by default. Switching using DI function 10 (GAIN-SEL, gain switching): DI logic invalid: PI control; DI logic valid: PI control.
1	The first gain and the second gain are switched by the setting value of P02-08.

P02-08	Parameter name	Setting method	Effective time	Default	Set range	Application category	Unit
	Gain switching condition selection	Operation setting	Effective immediately	0	0 to 10	Gain control	

Set the conditions for gain switching.

Setting value	Gain switching conditions	Details
0	The default is the first gain	Fixed use of the first gain
1	Switch by DI port	Use DI function 10 (GAIN-SEL, gain switching); DI logic is invalid: the first gain (P02-01~P02-03); DI logic is valid: the second gain (P02-04~P02-06).
2	Large torque command	In the previous first gain, when the absolute value of torque command is greater than (grade + hysteresis), the second gain is switched; In the previous second gain, when the absolute value of torque command is less than the value of (grade - hysteresis) and the duration is greater than [P02-13], the first gain is returned.
3	Large actual torque	In the previous first gain, when the absolute value of actual torque is greater than (grade + hysteresis), the second gain is switched; In the previous second gain, when the absolute value of actual torque is less than the value of (grade - hysteresis) and the duration is greater than [P02-13], the first gain is returned.
4	Large speed command	In the previous first gain, when the absolute value of speed command is greater than (grade + hysteresis), the second gain is switched; In the previous second gain, when the absolute value of speed command is less than the value of (grade - hysteresis) and the duration is greater than [P02-13], the first gain is returned.
5	Large actual speed	In the previous first gain, when the absolute value of actual speed is greater than (grade + hysteresis), the second gain is switched; In the previous second gain, when the absolute value of actual speed is less than the value of (grade - hysteresis) and the duration is greater than [P02-13], the first gain is returned.
6	Large rate of change in speed command	In the previous first gain, when the absolute value of the rate of change in speed command is greater than (grade + hysteresis), the second gain is switched; In the previous second gain, switch to the first gain when the absolute value of the rate of change in speed command is less than the value of (grade - hysteresis) and the duration is greater than [P02-13], the first gain is returned.

	7	Large position deviation	In the previous first gain, when the absolute value of position deviation is greater than (grade + hysteresis), the second gain is switched; In the previous second gain, switch to the first gain when the absolute value of position deviation is less than the value of (grade - hysteresis) and the duration is greater than [P02-13], the first gain is returned.
	8	Position command	In the previous first gain, if the position command is not 0, switch to the second gain; In the previous second gain, if the position command is 0 and the duration is greater than [P02-13], the first gain is returned.
	9	Positioning complete	In the previous first gain, if the positioning is not completed, the second gain is switched; In the previous second gain, if the positioning is not completed and the duration is greater than [P02-13], the first gain is returned.
	10	Position command + actual speed	In the previous first gain, if the position command is not 0, the second gain is switched; In the previous second gain, if the position command is 0, the duration is greater than [P02-13] and the absolute value of actual speed is less than (grade - hysteresis).

P02-13	Parameter name	Setting method	Effective time	Default	Set range	Application category	Unit
		Delay Time for Gain Switching	Operation setting	Effective immediately	20	0 to 10000	Gain control

The duration of the switching condition required for the second gain to switch back to the first gain.

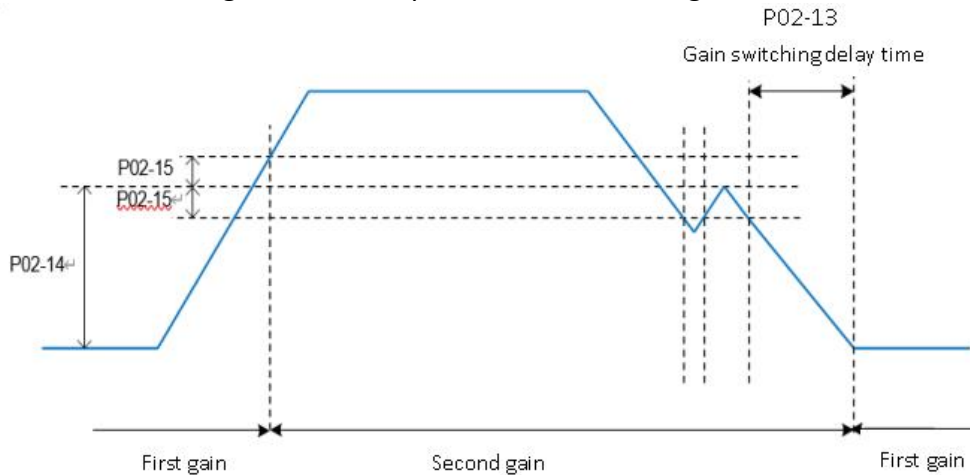

Note: This parameter is only valid when the second gain is switched back to the first gain.

P02-14	Parameter name	Setting method	Effective time	Default	Set range	Application category	Unit
		Gain switching grade	Operation setting	Effective immediately	50	0 to 20000	Gain control

Set the grade of the gain condition. The generation of the actual switching action is affected by the

two conditions of grade and hysteresis.

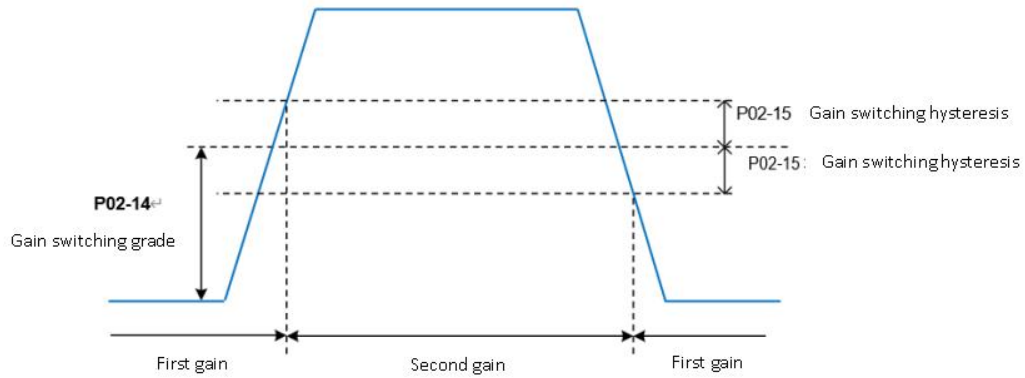

	Parameter name	Setting method	Effective time	Default	Set range	Application category	Unit
P02-15	Gain switching hysteresis	Operation setting	Effective immediately	20	0 to 20000	Gain control	According to the switching conditions

Set the hysteresis to meet the gain switching condition.

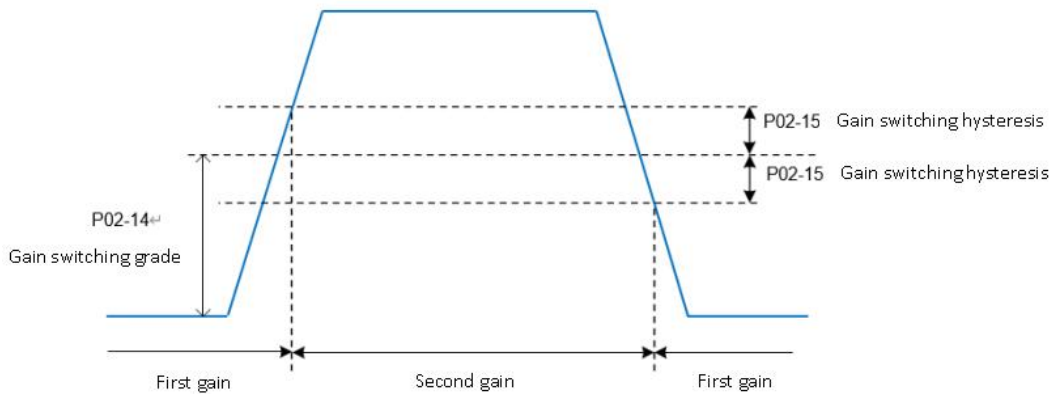

	Parameter name	Setting method	Effective time	Default	Set range	Application category	Unit
P02-16	Position loop gain switching time	Operation setting	Effective immediately	30	0 to 10000	Gain control	0.1ms

Set the time for switching from the first position loop (P02-01) to the second position loop (P02-04) in the position control mode.

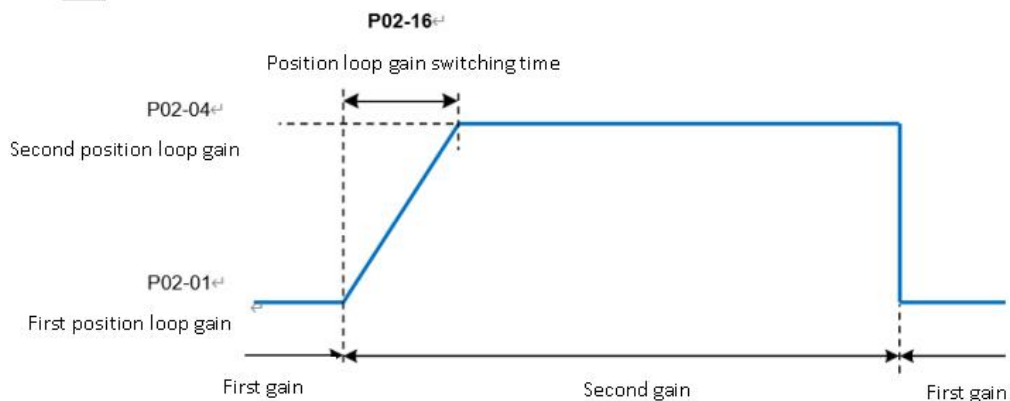

If $P02-04 \leq P02-01$, then P02-16 is invalid, and the second gain is switched from the first gain immediately.

7.4 Mechanical resonance suppression

7.4.1 Mechanical resonance suppression methods

When the mechanical rigidity is low, vibration and noise may occur due to resonance caused by shaft twisting, and it may not be possible to increase the gain setting. In this case, by using a notch filter to reduce the gain at a specific frequency, after resonance is effectively suppressed, you can continue to increase the servo gain. There are 2 methods to suppress mechanical resonance.

(1) Torque instruction filter

By setting the filter time constant, the torque instruction is attenuated in the high frequency range above the cutoff frequency, so as to achieve the expectation of suppressing mechanical resonance. The cut-off frequency of the torque instruction filter could be calculated by the following formula:

$$\text{Filter cutoff frequency } f_c(\text{Hz}) = \frac{1}{2\pi * \text{Set parameter value} * 0.001}$$

(2) Notch filter

The notch filter can achieve the expectation of suppressing mechanical resonance by reducing the gain at a specific frequency. When setting the notch filter correctly, the vibration can be effectively suppressed. You can try to increase the servo gain. The principle of the notch filter is shown in [Figure 7-11](#).

7.4.2 Notch filter

The VD2 series servo drives have 2 sets of notch filters, each of which has 3 parameters, namely notch frequency, width grade and depth grade.

(1) Width grade of notch filter

The notch width grade is used to express the ratio of the notch width to the center frequency of the notch:

$$\text{Notch filter width grade} = \frac{f_H - f_L}{f_T} \quad (7-1)$$

In formula (7-1), f_T is the center frequency of notch filter, that is, the mechanical resonance frequency; $f_H - f_L$ is the width of notch filter, which represents the frequency bandwidth with an amplitude attenuation rate of -3dB relative to the center frequency of notch filter.

(2) Depth grade of notch filter

The depth grade of notch filter represents the ratio relationship between input and output at center frequency.

When the notch filter depth grade is 0, the input is completely suppressed at center frequency.

When the notch filter depth grade is 100, the input is completely passable at center frequency.

Therefore, the smaller the the notch filter depth grade is set, the deeper the the notch filter depth, and the stronger the suppression of mechanical resonance. But the system may be unstable, you should pay attention to it when using it. The specific relationship is shown in Figure 7-12.

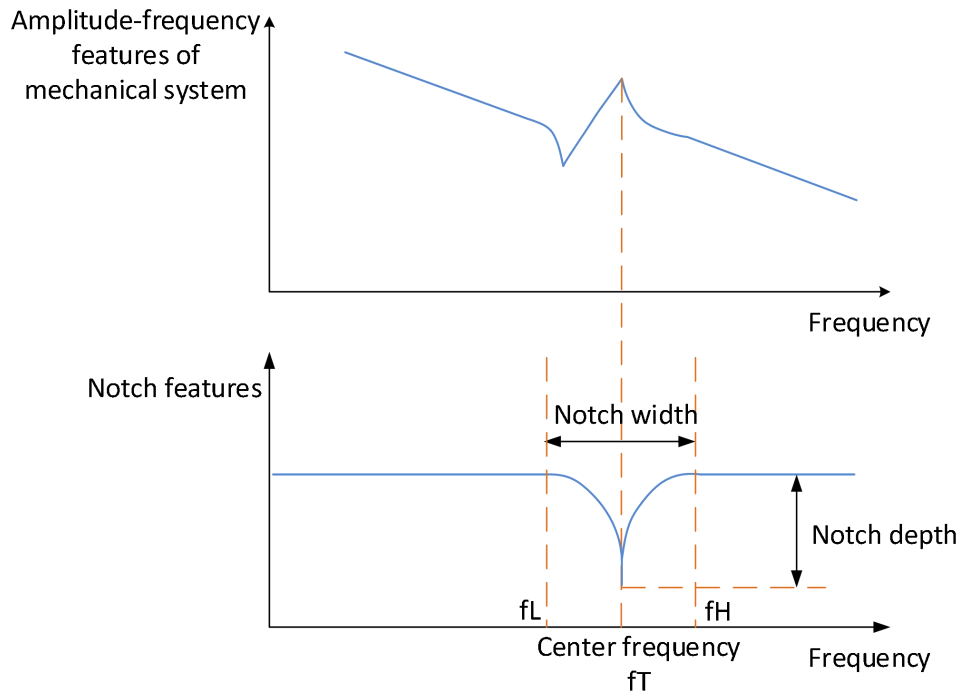

Figure 7-11 Notch characteristics, notch width, and notch depth

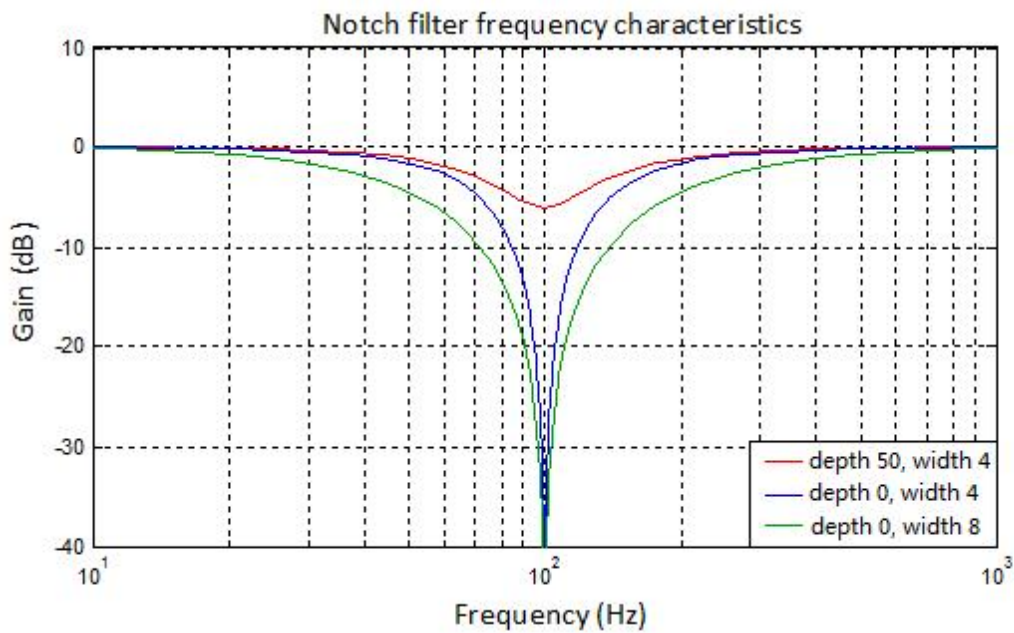

Figure 7-12 Frequency characteristics of notch filter

Function code	Name	Setting method	Effective time	Default value	Range	Definition	Unit
P04-05	1st notch filter frequency	Operation setting	Effective immediately	300	250 to 5000	Set the center frequency of the 1st notch filter. When the set value is 5000, the function of notch filter is invalid.	Hz
P04-06	1st notch filter depth	Operation setting	Effective immediately	100	0 to 100	0: all truncated 100: all passed	-
P04-07	1st notch filter width	Operation setting	Effective immediately	4	0 to 12	0: 0.5 times the bandwidth 4: 1 time the bandwidth 8: 2 times the bandwidth 12: 4 times the bandwidth	-

P04-08	2nd notch filter frequency	Operation setting	Effective immediately	500	250 to 5000	Set the center frequency of the 2nd notch filter. When the set value is 5000, the function of the notch filter is invalid.	Hz
P04-09	2nd notch filter depth	Operation setting	Effective immediately	100	0 to 100	0: all truncated 100: all passed	-
P04-10	2nd notch filter width	Operation setting	Effective immediately	4	0 to 12	0: 0.5 times the bandwidth 4: 1 time the bandwidth 8: 2 times the bandwidth 12: 4 times the bandwidth	-

Table 7-11 filter function code parameters

7.4.3 Low frequency vibration suppression

Low-frequency vibration suppression is suitable for working conditions where the motor vibrates during deceleration and shutdown after the position command is sent, and the vibration amplitude gradually decreases. The use of the low-frequency vibration suppression function is effective in reducing the time to complete positioning due to vibration effects.

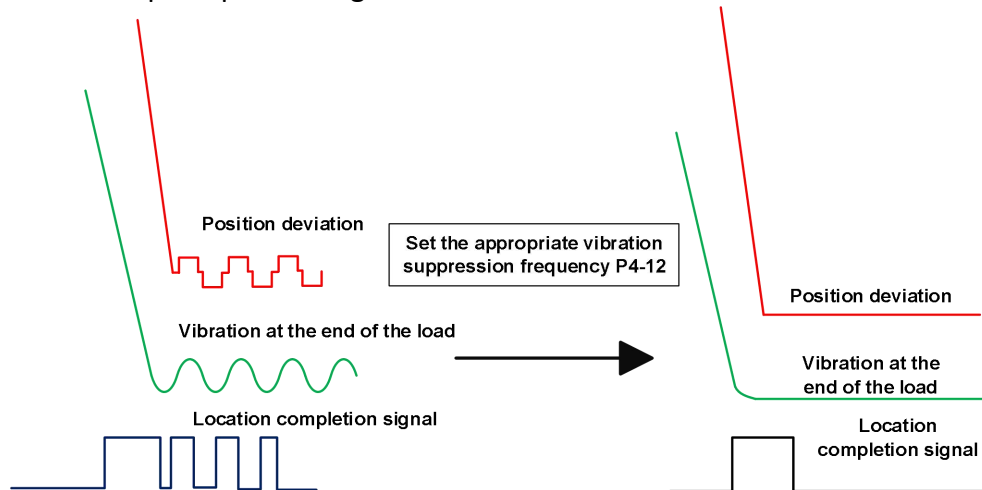

Figure 7-13 Applicable working conditions for low-frequency vibration suppression

Function code	Name	Setting method	Effective time	Default	Range	Definition	Unit
P4-11○	Enable low-frequency vibration suppression function	Operation setting	Effective immediately	0	0 to 1	When the function code is set to 1, enable the low-frequency vibration suppression function.	
P4-12○	Low-frequency vibration suppression frequency	Operation setting	Effective immediately	800	10 to 2000	Set the vibration frequency when vibration occurs at the load end.	0.1HZ
P4-14○	Shutdown vibration detection amplitude	Operation setting	Effective immediately	100	0 to 1000	When the vibration amplitude is greater than (P5-12*P4-14 detection amplitude ratio), the low-frequency vibration frequency can be recognized and updated to the U0-16 monitor quantity.	0.001

☆: Indicates that VD2F servo drive does not support this function code

○: Indicates that VD2L servo drive does not support this function code

★: Indicates that VD2F and VD2L servo drives do not support this function code

(1) Vibration frequency detection:

- ① Users can measure vibration by measuring equipment such as laser displacement.
- ② If no measuring equipment, the user can also read the position deviation waveform to confirm the vibration frequency through the "waveform" function of the PC debugging software.
- ③ Low-frequency vibration detection needs to be coordinated by the two parameters of completion positioning threshold and vibration detection amplitude. When the vibration amplitude is greater than $(P5-12 * P4-14)$ detection amplitude ratio, the low-frequency vibration frequency can be recognized and updated to U0-16 monitoring quantity. For example, when the vibration amplitude is greater than $(P5-12 * P4-14 * 0.001)$ detection amplitude ratio. For example, in $P05-12=800$, $P04_14=50$, the vibration amplitude is greater than $P5-12 * P4-14 * 0.001 = 800 * 50 * 0.001 = 40$ pulses, stop vibration frequency can be identified in U0-16.

(2) Debugging method:

- ① Set the appropriate positioning completion thresholds P5-12 and P4-14 to help the software detect the vibration frequency.
- ② Run the position curve command to obtain the vibration frequency, and obtain the frequency through the speed curve of oscilloscope or U0-16.
- ③ Set P4-12 vibration frequency and enable low frequency vibration suppression function P4-11. Run again to observe the speed waveform and determine whether to eliminate the vibration. If the vibration is not eliminated, please manually modify the vibration frequency and try again.

! CAUTION

If there is a speed substantial vibration and the vibration increases during the debugging, it may be that the low-frequency vibration suppression is not suitable for the current working conditions, please immediately close the servo, or power down!

7.4.4 Type A vibration suppression

Type A vibration suppression is suitable for durational vibration during motor operation or shutdown. Use Type A suppression to help reduce vibrations at specific frequencies that occur during motion (For the situation where the vibration continues to maintain and the vibration amplitude is almost constant after the command is completed.) As shown in [Figure 7-14](#).

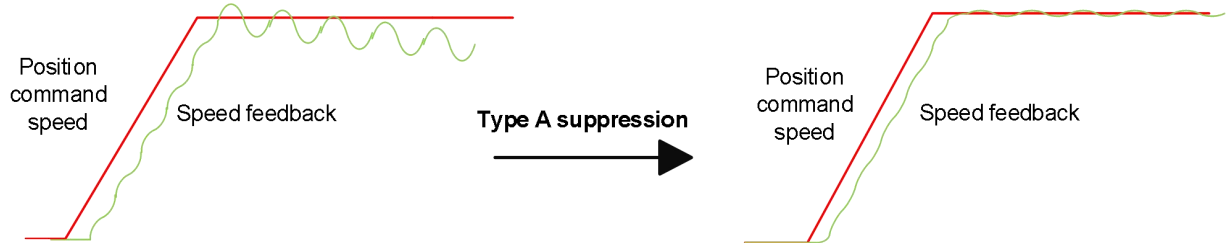

Figure 7-14 Applicable situations for type A vibration suppression

Function code	Name	Setting method	Effective time	Default	Range	Definition	Unit
P4-19○	Enable the type A suppression	Operation setting	Effective immediately	0	0 to 1	When the function code is set to 1, enable	

	function					the type A suppression function.	
P4-20○	Type A suppression frequency	Operation setting	Effective immediately	1000	100 to 20000	Set the frequency of Type A suppression.	0.1HZ
P4-21○	Type A suppression gain correction	Operation setting	Effective immediately	100	0 to 1000	Correct the load inertia ratio size.	0.01
P4-22○	Type A suppression damping gain	Operation setting	Effective immediately	0	0 to 500	The type A rejection compensation value is gradually increased until the vibration is reduced to the acceptable range.	0.01
P4-23○	Type A suppression phase correction	Operation setting	Effective immediately	200	0 to 900	Type A suppression phase compensation.	0.1 degree

☆: Indicates that VD2F servo drive does not support this function code

○: Indicates that VD2L servo drive does not support this function code

★: Indicates that VD2F and VD2L servo drives do not support this function code

(1) Vibration frequency detection:

The vibration frequency can directly obtain the value of the current vibration frequency from the software oscilloscope vibration frequency, combined with real-time speed waveform to observe the current vibration situation.

(2) Debugging method:

- ① Please set the correct inertia ratio parameter P3-1 when using type A vibration suppression,
- ② Run the position curve command, observe the servo host computer software waveform interface (sine wave) to obtain the vibration frequency.
- ③ Set P4-20 vibration frequency and enable type A vibration suppression function P4-19. (Type A vibration frequency takes effect when P4-19 is set to 1 for the first time. If change A-type vibration frequency P4-20, please set P4-19 to 0 again, then set to 1)
- ④ Set P4-22 damping gain, gradually increasing from 0, each time increasing about 20.
- ⑤ Observe the size of the vibration speed component, if the amplitude speed component is getting larger, it can be the vibration frequency setting error, if the vibration speed component is getting smaller, it means the vibration is gradually suppressed.
- ⑥ When the vibration is suppressed, there is still a small part of the vibration speed component, users can fine-tune the P4-23 phase correction, the recommended value of 150~300.

CAUTION

If there is a speed substantial vibration and the vibration increases during the debugging, it may be that the low-frequency vibration suppression is not suitable for the current working conditions, please immediately close the servo, or power down!

8. Communication

VD2 series servo drive has Modbus communication function, which could cooperate with the host computer for parameter modification, parameter query, monitoring volume servo status query and control. The servo drive is used as a slave device.

8.1 Modbus communication

8.1.1 Hardware wiring

The position of RS485 communication port (take VD2B as an example) is as the figure below.

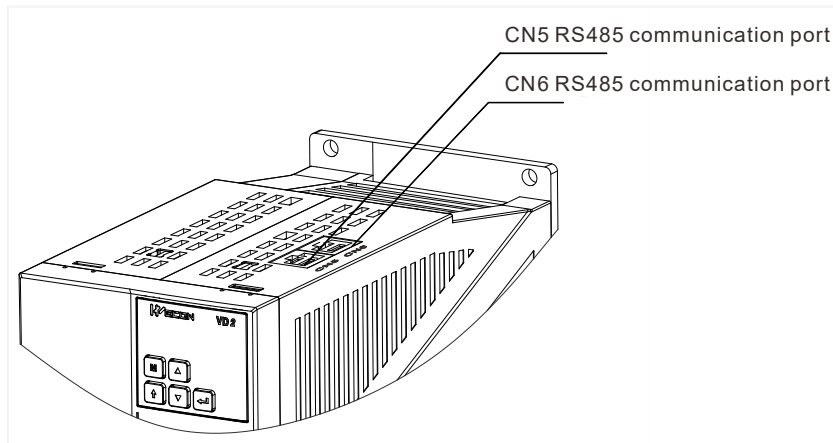

Figure 8-1 The position of RS485 communication port of VD2B drive

For the position of the RS485 communication port of other models, see [4.5 Communication signal wiring](#).

The servo drive adopts RS485 half-duplex communication mode. The 485 bus should adopt the hand-in-hand structure instead of the star structure or the bifurcated structure. The star structure or bifurcation structure will produce reflected signals, which will affect 485 communication.

! CAUTION

- ✎ The wiring must use shielded twisted pair, stay away from strong electricity, do not run in parallel with the power line, let alone bundle it together!
- ✎ In a half-duplex connection, only one servo drive can communicate with the host computer at the same time. If two or more servo drives upload data at the same time, bus competition will occur. Not only will it lead to communication failure, it may also cause some components to generate large currents and damage the components.

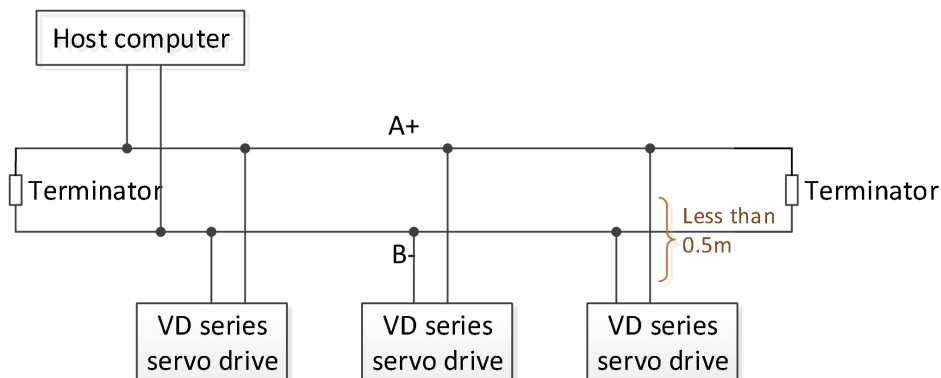
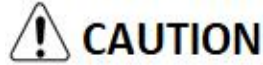

Figure 8-2 RS485 communication network wiring diagram

The terminal of RS485 network should use a terminating resistor of 120Ω to weaken the reflection of the signal. Intermediate networks cannot use terminating resistors.

No point in the RS485 network can be directly grounded. All devices in the network must be well grounded through their own grounding terminals.



The grounding wire cannot form a closed loop under no circumstances.

When wiring, consider the drive capability of the computer/PLC and the distance between the computer/PLC and the servo drive. If the drive capacity is insufficient, a repeater is needed.

8.2 Modbus communication protocol analysis

8.2.1 Modbus data frame format

The VD2 series servo drives currently support the RTU communication format. The typical data frame format is shown in the table.

There should be a message interval not less than 3.5 characters at the beginning	Address	Function code	Data	CRC check code
	1 byte	1 byte	N bytes	2 bytes

8.2.2 Description of supported function codes

The host reads and writes data to the servo through Modbus RTU format (03, 06 function codes). The corresponding Modbus function codes are as follows:

Operate	Command code
Read 16-bit/32-bit function code	0x03
Write 16-bit function code	0x06
Write 32-bit function code	0x10

(1) Read function code: 0x03

Request format:

Address	Function code	Initial address		Number of reads		CRC check code
		high byte	low byte	high byte	low byte	
1 byte	03	1 byte	1 byte	1 byte	1 byte	2 bytes

Correct response format:

Address	Function code	Number of bytes of returned data	Register 1		...	CRC check code
			high byte	low byte		
1 byte	03	1 byte	1 byte	1 byte	...	2 bytes

(2) Write function code: 0x06

Request format:

Address	Function code	Register address		Data		CRC check code
		high byte	low byte	high byte	low byte	
1 byte	06	1 byte	1 byte	1 byte	1 byte	2 bytes

Response format:

Address	Function code	Register address		Data		CRC check code
		high byte	low byte	high byte	low byte	
1 byte	06	1 byte	1 byte	1 byte	1 byte	2 bytes

If the setting is successful, the original is returned

There should be a message interval not less than 3.5 characters at the beginning	Address	Function code	Data	CRC check code
	1 byte	1 byte	N bytes	2 bytes

8.2.3 CRC check

The servo uses a 16-bit CRC check, and the host computer must also use the same check rule, otherwise the CRC check will make mistake. When transmitting, the low bit is in the front and the high bit is at the back. The CRC code are as follows:

```

    UInt16 CRC16_Calc(UInt8 *pBuf, UInt16 uLen)
    {
        UInt16 crc = 0xffff;
        UInt16 i;

        while(uLen--)
        {
            crc ^=(UInt16) *pBuf++;
            for(i=0; i<8; i++)
            {
                if(crc & 0x0001)
                {
                    crc = (crc >> 1) ^ 0xa001;
                }
                else
                {
                    crc = crc >> 1;
                }
            }
        }
        return crc;
    }
    
```

8.2.4 Error response frame

Address	Function code	Error code	CRC check code
1 byte	Command code+0x80	Error code	2 bytes

When an error occurs, set the function code bit7 issued by the host to 1, and return (for example, 0x03 returns 0x83, 0x06 returns 0x86); the description of the error code are as follows.

Error code	Coding description
0x0001	Illegal command code
0x0002	Illegal data address
0x0003	Illegal data
0x0004	Slave device failure

8.2.5 Communication example

03 Function code read

Read the monitoring volume U0-31 bus voltage, the Modbus register address corresponding to this variable is 7716 (0x1E24)

Request format:

Address	Function code	Register address		Data		CRC check code
		high byte	low byte	high byte	low byte	
01	03	1E	24	00	01	C2 29

The slave responds normally:

Address	Function code	Number of bytes	Data		CRC high byte
			high byte	low byte	
01	03	02	0C	4F	FC B0

The value read is 0x0C4F, which means that the voltage is 315.1V.

06 Function code write

P01-10 maximum speed threshold is set to 3000rpm. This variable corresponds to the Modbus address: 266 (0x010A)

Request format:

Address	Function code	Register address		Data		CRC check code
		high byte	low byte	high byte	low byte	
01	06	01	0A	0B	B8	AF, 76

The slave responds normally:

Address	Function code	Register address		Data		CRC check code
		high byte	low byte	high byte	low byte	
01	06	01	0A	0B	B8	AF, 76

10 Function code write

P07-09 set the 1st segment position to 2000, and this variable corresponds to the Modbus address: 1801 (0x0709).

Request format:

Address	Function code	Initial address		Number of register		Number of data	Data 1		Data 2		CRC check code	
		high byte	low byte	high byte	low byte		high byte	low byte	high byte	low byte	high byte	low byte
01	10	07	09	00	02	04	00	00	07	D0	16	59

The slave responds normally:

Address	Function code	Register address		Data		CRC check code	
		high byte	low byte	high byte	low byte	high byte	low byte
01	10	07	09	00	02	90	BE

8.3 Servo communication parameter setting

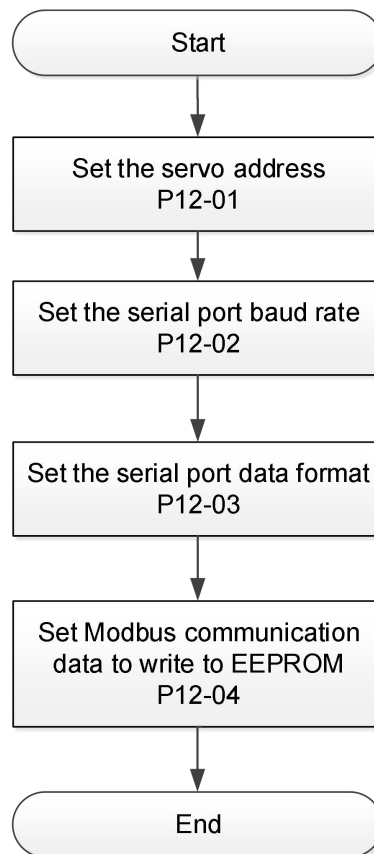

Figure 8-3 Modbus communication parameter setting process

(1) Set the servo address P12-1

When multiple servos are in network communication, each servo can only have a unique address, otherwise it will cause abnormal communication and fail to communicate.

(2) Set the serial port baud rate P12-2

The communication rate of the servo and the communication rate of the host computer must be set consistently, otherwise the communication cannot be carried out.

(3) Set the serial port data format P12-3

The data bit check methods of servo communication are:

Odd parity

Even parity

No parity

The stop bit: 1 stop bit and 2 stop bits.

The data frame format of the servo and the host computer must be consistent, otherwise the communication cannot be carried out.

(4) Set that whether the function code changed by Modbus communication is written into EEPROM in real time [P12-4]

When the host computer modifies the servo function code through communication, it can choose to store it in EEPROM in real time, which has the function of power-off storage.

If the value of the function code only needs to be rewritten once, and the value is used later, the function of real-time writing of the function code to EEPROM can be enabled.

If you need to change the value of the function code frequently, it is recommended to turn off the function of real-time writing to EERPOM of function code, otherwise the EEPROM will be shortened due to frequent erasing and writing of the EEPROM.



After the EEPROM is damaged, the servo will have a non-resettable fault!

(5) Set the high and low order of the 32-bit monitoring data

Part of the monitoring volume is 32-bit length and occupies 2 consecutive bias numbers. The user needs to set the order of the data high bit and low bit correctly, otherwise it will cause data reading and writing errors!

For example, U0-54 (position within 1 circle of absolute encoder) occupies two consecutive offset numbers, which are 0x1E3D and 0x1E3E respectively. Assuming the value of U0-54 is 0x12345678, the correct data sequence bit should be 0x1E3D=0x5678, 0x1E3E=0x1234 (little endian mode: low byte first, high byte behind.)

The description of related function codes are as follows.

Function code	Name	Setting method	Effective time	Default value	Range	Definition	Unit
P12-02	Baud rate	Operation setting	Effective immediately	2	0 to 5	0-2400bps 1-4800bps 2-9600bps 3-19200bps 4-38400bps 5-57600bp	-
P12-03	Serial data format	Operation setting	Effective immediately	0	0 to 3	0: 1 stop bit, no parity 1: 1 stop bit, odd parity 2: 1 stop bit, even parity 3: 2 stop bits, no parity	-
P12-04	Modbus communication data is written into EEPROM	Operation setting	Effective immediately	0	0 to 1	0: Do not write to EEPROM, and do not store after power failure; 1: Write to EEPROM, power-down storage.	-
P12-06	Modbus 32-bit variable big endian and little endian	Operation setting	Effective immediately	0	0-1	0: Big-endian mode, the lower address stores the higher 16 bits of data, and the higher address stores the lower 16 bits of data 1: Little-endian mode, the lower address stores the lower 16 bits of data, and the higher address stores the higher 16 bits of data	

8.4 Modbus communication variable address and value

8.4.1 Variable address description

Modbus registers are divided into two categories:

- ① The first category is servo function code parameters (address: 0x0001 to 0x0D08), this part of the register is readable and writable (that is, 0x03 and 0x06 are supported);
- ② The second category is the monitoring volume of the servo (address: 0x1E01 to 0x2010), this part of the register is only readable (0x03 function is supported).

Servo function code representation: PXX-YY.

- XX: represents the function code group number,
- YY: represents the bias within the function code group;

During servo communication, the communication address of the function code is a 16-bit address, which is composed of the function code group number (high 8 bits) + group bias (low 8 bits), for example, the Modbus address corresponding to P12-1 (servo address) is 0x0C01.

Servo monitor volume representation: Uxx-yy.

- xx: represents the monitoring volume group number,
- yy: represents the bias within the monitoring volume group;

During Modbus communication, the starting address of the monitoring volume is 0x1E01, and the conversion relationship of the address is similar to the representation way of the function code.

For example, U0-01 (servo status) corresponds to the Modbus address is 0x1E01.

In order to facilitate actual use, this manual provides both decimal and hexadecimal address identification, it is shown in the following table:

Function code	Modbus address (Hexadecimal)	Modbus address (Decimal)	Category	Name
P00-01	0x0001	1	Basic settings	Control mode

For detailed parameter addresses, please refer to "[11.1 Lists of parameters](#)".

8.4.2 Variable value type description

When writing function codes with signed numbers, you need to convert the pre-written data into hexadecimal complements. The conversion rules are as follows:

- ① The data is positive or 0: complement code = original code
- ② The data is negative: complement code = 0xFFFF-absolute value of data + 0x0001

For example,

The 16-bit signed positive number +100, the original code is 0x0064, and the complement is: 0x0064.

The 16-bit signed positive number -100, its hexadecimal complement is: 0xFFFF-0x0064 + 0x0001 = 0xFF9C.

If it is an unsigned number, just pass it directly according to its original code. For example, if the decimal number is 32768, write 0x8000 directly.

8.4.3 Numerical unit description

Some values have units and decimals, such as 0.1%, 0.1Hz, 0.01ms, and the corresponding value conversion is required when reading and writing. The methods are as follows:

- ① When the unit is 0.1%: 1 represents 0.1%, 10 represents 1.0%, 1000 represents 100.0%.

Therefore, writing 1000 means setting to 100.0%; on the contrary, if it is reading 1000, it means that the value is 100.0%;

② When the unit is 0.01ms: 1 means 0.01ms, 50 means 0.5ms, 10000 means 100ms.
Therefore, writing 1000 means setting to 10.00ms; on the contrary, if 1000 is read, it means 10.00ms;
The other units can be deduced by this, and integer remains unchanged.

9. Parameters

Group P00 Basic settings

P00-01	Parameter name	Setting method	Effective time	Default	Range	Category	Unit
	Control mode	Shutdown setting	Effective immediately	1	1 to 6	Basic setting	-

Used to set the control mode of servo drive

Setting value	Control mode	Remarks						
1	Position control	For position control parameter setting, please refer to 6.2 Position control mode						
2	Speed control	For speed control parameter setting, please refer to 6.3 Speed control mode						
3	Torque control	For torque control parameter setting, please refer to 6.4 Torque control mode						
4	Position/speed mix control	A DI terminal of the servo drive needs to be assigned to function 17 (MixModeSel, mixed mode selection), and the DI terminal logic is determined to be valid.						
		<table border="1"> <thead> <tr> <th>MixModeSel terminal logic</th> <th>Control mode</th> </tr> </thead> <tbody> <tr> <td>Invalid</td> <td>Position control</td> </tr> <tr> <td>Valid</td> <td>Speed control</td> </tr> </tbody> </table>	MixModeSel terminal logic	Control mode	Invalid	Position control	Valid	Speed control
		MixModeSel terminal logic	Control mode					
Invalid	Position control							
Valid	Speed control							
<table border="1"> <thead> <tr> <th>MixModeSel terminal logic</th> <th>Control mode</th> </tr> </thead> <tbody> <tr> <td>Invalid</td> <td>Position control</td> </tr> <tr> <td>Valid</td> <td>Speed control</td> </tr> </tbody> </table>	MixModeSel terminal logic	Control mode	Invalid	Position control	Valid	Speed control		
MixModeSel terminal logic	Control mode							
Invalid	Position control							
Valid	Speed control							
5	Position/torque mix control	A DI terminal of the servo drive needs to be assigned to function 17 (MixModeSel, mixed mode selection), and the DI terminal logic is determined to be valid.						
		<table border="1"> <thead> <tr> <th>MixModeSel terminal logic</th> <th>Control mode</th> </tr> </thead> <tbody> <tr> <td>Invalid</td> <td>Position control</td> </tr> <tr> <td>Valid</td> <td>Torque control</td> </tr> </tbody> </table>	MixModeSel terminal logic	Control mode	Invalid	Position control	Valid	Torque control
		MixModeSel terminal logic	Control mode					
Invalid	Position control							
Valid	Torque control							
<table border="1"> <thead> <tr> <th>MixModeSel terminal logic</th> <th>Control mode</th> </tr> </thead> <tbody> <tr> <td>Invalid</td> <td>Position control</td> </tr> <tr> <td>Valid</td> <td>Torque control</td> </tr> </tbody> </table>	MixModeSel terminal logic	Control mode	Invalid	Position control	Valid	Torque control		
MixModeSel terminal logic	Control mode							
Invalid	Position control							
Valid	Torque control							
6	Speed/torque mix control	A DI terminal of the servo drive needs to be assigned to function 17 (MixModeSel, mixed mode selection), and the DI terminal logic is determined to be valid.						
		<table border="1"> <thead> <tr> <th>MixModeSel terminal logic</th> <th>Control mode</th> </tr> </thead> <tbody> <tr> <td>Invalid</td> <td>Speed control</td> </tr> <tr> <td>Valid</td> <td>Torque control</td> </tr> </tbody> </table>	MixModeSel terminal logic	Control mode	Invalid	Speed control	Valid	Torque control
		MixModeSel terminal logic	Control mode					
Invalid	Speed control							
Valid	Torque control							
<table border="1"> <thead> <tr> <th>MixModeSel terminal logic</th> <th>Control mode</th> </tr> </thead> <tbody> <tr> <td>Invalid</td> <td>Speed control</td> </tr> <tr> <td>Valid</td> <td>Torque control</td> </tr> </tbody> </table>	MixModeSel terminal logic	Control mode	Invalid	Speed control	Valid	Torque control		
MixModeSel terminal logic	Control mode							
Invalid	Speed control							
Valid	Torque control							

When P00-01 is set to 4, 5 or 6, please refer to [6.5 Mixed control mode](#).

Note: VD2L driver P0-01 setting range: 1 to 3. Mix mode is not supported!

P00-04	Parameter name	Setting method	Effective time	Default	Range	Category	Unit
	Rotation direction	Shutdown setting	Effective immediately	0	0 to 1	Basic setting	-

Set the forward rotation direction of the motor when looking at the motor axis.

Setting value	Rotation direction	Remarks
0	Take CW as forward direction	When looking at the motor axis, the rotation direction of the motor is clockwise
1	Take CCW as forward direction	When looking at the motor axis, the rotation direction of the motor is anticlockwise

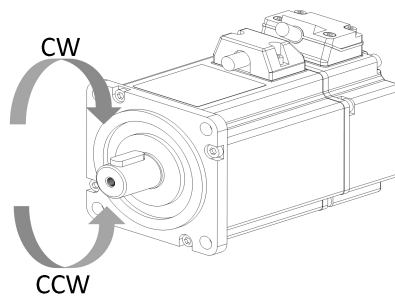

Parameter name	Setting method	Effective time	Default	Range	Category	Unit	
P00-05	Servo OFF shutdown method	Shutdown setting	Effective immediately	0	0 to 1	Basic setting	-
Set the forward rotation direction of the motor when looking at the motor axis.							
Setting value	Shutdown method	Remarks					
0	Free shutdown. The motor shaft remains free	Please set reasonable shutdown according to the machinery and running requirement. Please refer to 6.1.7 Servo shutdown					
1	Zero-speed shutdown. The motor shaft remains free						

Parameter name	Setting method	Effective time	Default	Range	Category	Unit	
P00-09	Braking resistor setting	Operation setting	Effective immediately	0	0 to 3	Basic setting	-
Used to set the way in which braking energy is absorbed and released.							
Setting value	Braking resistor setting	Remarks					
0	Use built-in braking resistor	Please refer to 6.1.5 Braking resistor to choose the right braking method					
1	Use external braking resistor and natural cooling						
2	Use external braking resistor and forced air cooling (not settable)						
3	No braking resistors are used, and all are absorbed by capacitance						
<p>Note: VD2-010SA1G and VD2F-010SA1P drives has no built-in braking resistor by default, so the default value of P00-09 is 3 (No braking resistors are used, and all are absorbed by capacitance).</p>							

Parameter name	Setting method	Effective time	Default	Range	Category	Unit	
P00-10	External braking resistor value	Operation setting	Effective immediately	50	0 to 65535	Basic setting	Ω
<p>Used to set the power of external braking resistor of servo drive.</p> <p>When the maximum braking energy calculated value is greater than the maximum braking energy absorbed by capacitor, and the braking power calculated value is greater than the built-in braking resistor power, use external braking resistor.</p> <p>If the value of P00-10 is too large, Er.25 (too large braking resistor value) or Er.22 (main power supply is over voltage) will occur.</p> <p>When using an external braking resistor, the short wiring between C and D must be disconnected, and the external braking resistor should wiring between P+ and D.</p> <p>Please refer to 2.1.2 The composition of the servo drives.</p>							

Parameter name	Setting method	Effective time	Default	Range	Category	Unit	
P00-11	External braking resistor power	Operation setting	Effective immediately	100	0 to 65535	Basic setting	W
Used to set resistor value of external braking resistor of servo drive. The power of external braking resistor (P00-11) can not less than the braking resistance power calculation value.							

Parameter name	Setting method	Effective time	Default	Range	Category	Unit	
P00-12	Position pulse type selection	Operation setting	Power-on again	0	0 to 5	Position mode	-

In position control mode, when position instruction source is pulse instruction (P01-06=0), input pulse pattern.

Setting value	Pulse pattern	Remarks
0	Direction + pulse(positive logic)	Please refer to Table 6-15 in 6.2.1 Position instruction input setting
1	CW/CCW	
2	AB phase orthogonal pulse (4 times frequency)	
3	Direction + pulse (negative logic)	
4	CW/CCW (negative logic)	
5	AB phase orthogonal pulse (4 times frequency negative logic)	

⚠Note: VD2L series drivers do not support the pulse form of CW/CCW! P0-12 parameter setting range of VD2L: 0, 2, 3, 5

Parameter name	Setting method	Effective time	Default	Range	Category	Unit
P00-13 Maximum position pulse frequency	Shutdown setting	Effective immediately	300	1 to 500	Position mode	KHz

In position control mode, when position instruction source is pulse instruction (P01-06=0), input the maximum frequency of pulse When the actual pulse input frequency is greater than the setting value of P00-13, A-86 would occurs (The input pulse frequency is too high).

Parameter name	Setting method	Effective time	Default	Range	Category	Unit
P00-14 Position pulse anti-interference level	Operation setting	Power-on again	2	0 to 9	Position mode	-

In position control mode, filter the input pulse. The larger the P00-14 setting value, the greater the filter depth.

⚠Note: P0-14 filtering time of the VD2L series drive is not consistent with that of other VD2 series models.

VD2/VD2F	
Setting value	Filtering time
0	No filtering
1	128ns
2	256ns
3	512ns
4	1.024us
5	2.048us
6	4.096us
7	8.192us
8	16.384us
9	VD2: 32.768us
	VD2F: 25.5us

VD2L	
Setting value	Filtering time
0	No filtering
1	111.1ns
2	222.2ns
3	444.4ns
4	888.8us
5	1777.7us
6	3555.5us
7	7111.7us
8	14222.2us

Parameter name	Setting method	Effective time	Default	Range	Category	Unit
P00-16 Number of instruction pulses per turn of motor	Shutdown setting	Effective immediately	10000	0 to 131072	Position mode	W

Used to set the number of instruction pulses required for per turn of motor

Parameter name	Setting method	Effective time	Default	Range	Category	Unit
P00-17 Electronic gear 1 numerator	Operation setting	Effective immediately	1	0 to 4294967294	Position mode	W

Used to set the numerator of the first group electronic gear for position instruction. This function code is only valid when P00-16=0.

⚠Note:

The setting range of VD2L is inconsistent with other models of VD2 series as follows: 1 to 2147483647.

Parameter name	Setting method	Effective time	Default	Range	Category	Unit
P00-18						

	Electronic gear 1 denominator	Operation setting	Effective immediately	1	0 to 4294967294	Position mode	W
Used to set the numerator of the first group electronic gear for position instruction. This function code is only valid when P00-16=0.							
Note: The setting range of VD2L is inconsistent with other models of VD2 series as follows: 1 to 2147483647.							

	Parameter name	Setting method	Effective time	Default	Range	Category	Unit
P00-19	Electronic gear 2 numerator	Operation setting	Effective immediately	1	0 to 4294967294	Position mode	W
Used to set the numerator of the second group electronic gear for position instruction. This function code is only valid when P00-16=0.							
Note: The setting range of VD2L is inconsistent with other models of VD2 series as follows: 1 to 2147483647.							

	Parameter name	Setting method	Effective time	Default	Range	Category	Unit
P00-20	Electronic gear 2 denominator	Operation setting	Effective immediately	1	0 to 4294967294	Position mode	W
Used to set the numerator of the second group electronic gear for position instruction. This function code is only valid when P00-16=0.							
Note: The setting range of VD2L is inconsistent with other models of VD2 series as follows: 1 to 2147483647.							

	Parameter name	Setting method	Effective time	Default	Range	Category	Unit						
P00-21 ☆	Pulse frequency division output direction	Operation setting	Power-on again	0	0 to 1	Position mode	-						
Used to set the pulse frequency division output direction													
<table border="1"> <thead> <tr> <th>Setting value</th> <th>Output direction</th> </tr> </thead> <tbody> <tr> <td>0</td> <td>CW is forward direction (A is ahead of B)</td> </tr> <tr> <td>1</td> <td>CCW is forward direction (A is ahead of B)</td> </tr> </tbody> </table>								Setting value	Output direction	0	CW is forward direction (A is ahead of B)	1	CCW is forward direction (A is ahead of B)
Setting value	Output direction												
0	CW is forward direction (A is ahead of B)												
1	CCW is forward direction (A is ahead of B)												
VD2L is used to set the pulse frequency division output direction.													
<table border="1"> <thead> <tr> <th>Setting value</th> <th>Output direction</th> </tr> </thead> <tbody> <tr> <td>0</td> <td>Direction+pulse (Positive logic)</td> </tr> <tr> <td>1</td> <td>Direction+pulse (Negative logic)</td> </tr> </tbody> </table>								Setting value	Output direction	0	Direction+pulse (Positive logic)	1	Direction+pulse (Negative logic)
Setting value	Output direction												
0	Direction+pulse (Positive logic)												
1	Direction+pulse (Negative logic)												

“☆” indicates that the VD2F servo drive does not support this function code.

	Parameter name	Setting method	Effective time	Default	Range	Category	Unit
P00-22 ☆	The number of output pulses per turn of motor	Operation setting	Power-on again	2500	0 to 2500	Position mode	-
Note: In addition to VD2L models, every time the VD2 series motor rotates, Phase A and Phase B can each output up to 2,500 pulses, and the upper receiving device needs to support 4 times frequency analysis to obtain 10,000 pulses.							
[Attention]! The setting range of this parameter for VD2L is inconsistent with that for other models of VD2 series as follows: 0 to 10000.							

“☆” indicates that the VD2F servo drive does not support this function code.

	Parameter name	Setting method	Effective time	Default	Range	Category	Unit						
P00-23 ☆	Z pulse output OZ polarity	Operation setting	Power-on again	0	0 to 1	Position mode	-						
Used to set the level logic of Z pulse													
<table border="1"> <thead> <tr> <th>Setting value</th> <th>Output direction</th> </tr> </thead> <tbody> <tr> <td>0</td> <td>Active high level</td> </tr> <tr> <td>1</td> <td>Active low level</td> </tr> </tbody> </table>								Setting value	Output direction	0	Active high level	1	Active low level
Setting value	Output direction												
0	Active high level												
1	Active low level												

P00-24	Parameter name	Setting method	Effective time	Default	Set range	Application category	Unit
	Z pulse output width	Operation setting	Power on again	3	1 to 200	Position mode	ms
Set Z pulse output width: 1: Pulse width 1ms 2: Pulse width 2ms 200: Pulse width 200ms Note: This function code is only supported by VD2F series models!							

P00-25	Parameter name	Setting method	Effective time	Default	Range	Category	Unit
	Position deviation limit	Shutdown setting	Effective immediately	60000	0 to 2147483646	Position mode	Equivalent pulse unit
Used to set position deviation limit value. When the actual deviation of motor exceeds the setting value of this function code, Er.36 would occurs (position deviation is too large). When the function code is set to 0, positional bias is ignored.							

P00-27	Parameter name	Setting method	Effective time	Default	Range	Category	Unit
☆	Pulse output frequency division numerator	Operation setting	Power-on again	1	1 to 2500	Position mode	-
Orthogonal coded output (numerator/denominator format). Used to set pulse output frequency division numerator. (When P00-22=0, and the pulse output frequency division numerator value is less than the pulse output frequency division denominator value, this function code is valid)							

☆: Indicates that VD2F servo drive does not support this function code

○: Indicates that VD2F servo drive does not support this function code

★: Indicates that VD2F and VD2L servo drives do not support this function code

P00-28	Parameter name	Setting method	Effective time	Default	Range	Category	Unit
☆	Pulse output frequency division denominator	Operation setting	Power-on again	1	1 to 2500	Position mode	-
Orthogonal coded output (numerator/denominator format). Used to set pulse output frequency division denominator. (When P00-22=0, and the pulse output frequency division denominator value is greater than the pulse output frequency division numerator value, this function code is valid)							

☆: Indicates that VD2F servo drive does not support this function code

○: Indicates that VD2F servo drive does not support this function code

★: Indicates that VD2F and VD2L servo drives do not support this function code

P00-29	Parameter name	Setting method	Effective time	Default	Range	Category	Unit
	The number of equivalent position units in one circle	Shutdown setting	Effective immediately	10000	0 to 131072	Position mode	-
The equivalent position unit of one circle of the motor							

P00-30	Parameter name	Setting method	Effective time	Default	Range	Category	Unit
	Shielded multi-turn absolute encoder battery failure	Operation setting	Power-on again	0	0 to 3	Basic setting	-

Used to set multi-turn absolute encoder battery fault alarm setting function. (VD2-SA V1.13 firmware added)

Setting value	Function	Remarks
0	Not shield	Detect multi-turn absolute encoder battery under voltage and battery low-voltage fault. Please refer to 6.6 Absolute system .
1	Shield multi-turn absolute motor battery fault	Shield multi-turn absolute encoder battery under voltage and battery low-voltage fault. This would cause mechanical failure, please use with caution.
2	Shielded encoder overtemperature fault	Shield multi-turn absolute value encoder battery under temperature fault, which is very likely to cause mechanical failure. Please use it carefully!
3	Simultaneously shielding multi-turn absolute value motor battery fault and encoder overtemperature fault	Shield absolute value encoder battery undervoltage and low voltage fault and multi-turn absolute value encoder battery under temperature fault, which are likely to cause mechanical failure. Please use it carefully!

	Parameter name	Setting method	Effective time	Default	Range	Category	Unit
P00-31	Encoder read-write check abnormal frequency	Operation setting	Effective immediately	20	0 to 100	Basic setting	-
	0: no alarm Other values: After exceeding this set value, A93 encoder read/write verification abnormal frequency warning will be reported.						

Group P01 Control parameters

	Parameter name	Setting method	Effective time	Default	Range	Category	Unit
P01-01	Speed instruction source	Shutdown setting	Power-on again	0	0 to 1	Speed mode	-
	Select speed instruction source						
Setting value	Function	Remarks					
0	Internal speed instruction	Please refer to 6.3.1 Speed instruction input setting .					
1*	AI_1 analog input	Please refer to 4 Wiring .					
“*” indicates that the VD2F servo drive does not support this function code.							

	Parameter name	Setting method	Effective time	Default	Range	Category	Unit
P01-02	Internal speed instruction 0	Operation setting	Effective immediately	0	-5000 to 5000	Speed mode	rpm
	Used to set speed value of internal speed instruction when servo drive is in speed control mode, and only valid when P01-01=0.						

	Parameter name	Setting method	Effective time	Default	Range	Category	Unit
P01-03	Acceleration time	Operation setting	Effective immediately	50	0 to 65535	Speed mode	ms
	The time that the speed instruction accelerates from 0 to 1000 rpm. Please refer to 6.3.2 Acceleration and deceleration time setting						

	Parameter name	Setting method	Effective time	Default	Range	Category	Unit
P01-04	deceleration time	Operation setting	Effective immediately	50	0 to 65535	Speed mode	ms
	The time that the speed instruction decelerates from 0 to 1000 rpm. Please refer to 6.3.2 Acceleration and deceleration time setting						

	Parameter name	Setting method	Effective time	Default	Range	Category	Unit
P01-05	Shutdown deceleration time	Shutdown setting	Effective immediately	50	0 to 65535	-	ms
The time for the speed command to decelerate from 1000rpm to 0							

	Parameter name	Setting method	Effective time	Default	Range	Category	Unit
P01-06	Position instruction source	Operation setting	Effective immediately	0	0 to 1	-	-
Used to select position instruction source when servo drive is in position control mode.							
Setting value	Instruction source	Remarks					
0	Pulse instruction	Pulse instructions are generated by PLC or other pulse generator and input to servo drive via the hardware terminals. Please refer to 6.2.1 Position instruction input setting					
1	Internal position instruction	The internal multi-segment position instruction is triggered by DI function 20 (internal multi-segment position enable signal). Please refer to internal multi-segment position function .					

	Parameter name	Setting method	Effective time	Default	Range	Category	Unit
P01-07	Torque instruction source	Shutdown setting	Effective immediately	0	0 to 1	Torque mode	-
Used to select torque instruction source when servo drive is in torque control mode.							
Setting value	Instruction source	Remarks					
0	Internal torque instruction	Please refer to 6.4.1 Torque instruction input setting					
1*	AI_1 analog input	Please refer to 4 Wiring					
** indicates that the VD2F and VD2L servo drive cannot support this instruction source							

P01-08	Parameter name	Setting method	Effective time	Default	Range	Category	Unit
	Torque instruction keyboard setting value	Operation setting	Effective immediately	0	-3000 to 3000		0.1%
Used to set the required torque instruction value when P01-07 is set to 0 (internal torque instruction).							
P01-09	Parameter name	Setting method	Effective time	Default	Range	Category	Unit
	Speed limit source in torque mode	Shutdown setting	Effective immediately	0	0 to 1	Torque mode	-
Used to set speed limit source when servo drive is in torque control mode.							
Setting value	Instruction source	Remarks					
0	Internal instruction	Please refer to 6.4.4 Speed limit in torque mode					
1*	AI_2 analog input	Please refer to 4 Wiring					
** indicates that the VD2F servo drive does not support this instruction source.							

P01-10	Parameter name	Setting method	Effective time	Default	Range	Category	Unit
	Maximum speed threshold	Operation setting	Effective immediately	3600	0 to 5000	Protection and restriction	rpm
Used to set the maximum speed limit value. If the actual speed of motor exceeds this value, Er.32 would occur (Exceed the maximum speed of motor).							

P01-11	Parameter name	Setting method	Effective time	Default	Range	Category	Unit
	Warning speed threshold	Operation setting	Effective immediately	3300	0 to 5000	Protection and restriction	rpm
Used to set the limit value of maximum speed. If the actual speed of motor exceeds this value, A-81 would occur (Exceed the maximum speed of motor).							

P01-12	Parameter name	Setting method	Effective time	Default	Range	Category	Unit
	Forward speed threshold	Operation setting	Effective immediately	3000	0 to 5000	Protection and restriction	rpm
Used to set the limit value of forward speed							

P01-13	Parameter name	Setting method	Effective time	Default	Range	Category	Unit
	Reverse speed threshold	Operation setting	Effective immediately	3000	0 to 5000	Protection and restriction	rpm
Used to set the limit value of reverse speed							

P01-14	Parameter name	Setting method	Effective time	Default	Range	Category	Unit
	Torque limit source	Shutdown setting	Effective immediately	0	0 to 1	Protection and restriction	-
Used to select torque instruction source when servo drive is in torque control mode.							
Setting value	Instruction source	Remarks					
0	Internal instruction	Please refer to 6.4.3 Torque instruction limit					
1	AI_2 analog input	Please refer to 4 Wiring					

P01-15	Parameter name	Setting method	Effective time	Default	Range	Category	Unit
	Forward torque limit	Operation setting	Effective immediately	3000	0 to 3000	Protection and restriction	0.1%
Used to set the limit value of forward speed							

P01-16	Parameter name	Setting method	Effective time	Default	Range	Category	Unit
	Reverse torque limit	Operation setting	Effective immediately	3000	0 to 3000	Protection and restriction	0.1%
When P01-14 is set to 0 (internal) , the setting value of this function code is reverse torque limit value. If the value of P01-15 and P01-16 is set too small, the servo motor may be insufficient torque phenomenon when performing acceleration and deceleration movements. Please refer to 6.4.3 Torque instruction limit .							

P01-17	Parameter name	Setting method	Effective time	Default	Range	Category	Unit
	Forward speed limit in torque mode	Operation setting	Effective immediately	3000	0 to 5000	Protection and restriction	rpm

Used to set forward speed limit value in torque control mode. Please refer to [6.4.4 Speed limit in torque mode](#)

P01-18	Parameter name	Setting method	Effective time	Default	Range	Category	Unit
	Reverse speed limit in torque mode	Operation setting	Effective immediately	3000	0 to 5000	Protection and restriction	rpm

Used to set reverse speed limit value in torque control mode. Please refer to [6.4.4 Speed limit in torque mode](#)

P01-19	Parameter name	Setting method	Effective time	Default	Range	Category	Unit
	Torque saturation timeout	Operation setting	Effective immediately	3000	0 to 65535	Protection and restriction	ms

When torque is limited by the setting value of P01-15 or P01-16, and exceeds the setting time, drive would report fault “torque saturation abnormal”.

Note: When the value of this function code is set to 0, the torque saturation timeout fault detection is not executed, and this fault is ignored.

P01-21	Parameter name	Setting method	Effective time	Default	Range	Category	Unit
	Zero-speed clamp function selection	Operation setting	Effective immediately	0	0 to 3	Speed mode	-

Please refer to [6.3.4 Zero-speed clamp function](#)

Setting value	Function
0	Force speed to 0
1	Force speed to 0, and keep position locked when the actual speed is less than P01-22
2	When the actual speed is less than P01-22, force speed to 0, and keep position locked
3	Invalid. Ignore zero-speed clamp input

P01-22	Parameter name	Setting method	Effective time	Default	Range	Category	Unit
	Zero speed clamp speed threshold	Operation setting	Effective immediately	20	0 to 5000	Speed mode	rpm

Used to set the speed threshold of zero-speed clamp function Please refer to [6.3.4 Zero-speed clamp function](#). [6.4.4 Speed limit in torque mode](#)

P01-23	Parameter name	Setting method	Effective time	Default	Range	Category	Unit
	Internal speed Instruction 1	Operation setting	Effective immediately	0	-5000 to 5000	Speed mode	rpm

Used to set the speed value of internal speed instruction 2. To use internal speed instruction 1 to 7, you need to set 3 DI terminals as DI function 13 (INSPD1, internal speed instruction 1) to (INSPD3, internal speed instruction 3) . The switch of the internal speed instruction section is realized by controlling the DI terminal logic of the servo control device. The running instruction segment number is 3-bit binary number. The corresponding relationships between internal speed instruction 1 to 3 and running segment number are as below.

INSPD3	INSPD2	INSPD1	Internal speed instruction segment number
0	0	0	0
0	0	1	1
0	1	0	2
.....			
1	1	1	7

Please refer to [6.3.1 Speed instruction input setting](#)

P01-24	Parameter name	Setting method	Effective time	Default	Range	Category	Unit
	Internal speed Instruction 2	Operation setting	Effective immediately	0	-5000 to 5000	Speed mode	rpm

Used to set the speed value of internal speed instruction 2.

P01-25	Parameter name	Setting method	Effective time	Default	Range	Category	Unit
--------	----------------	----------------	----------------	---------	-------	----------	------

	Internal speed Instruction 3	Operation setting	Effective immediately	0	-5000 to 5000	Speed mode	rpm
Used to set the speed value of internal speed instruction 3.							
P01-26	Parameter name	Setting method	Effective time	Default	Range	Category	Unit
	Internal speed Instruction 4	Operation setting	Effective immediately	0	-5000 to 5000	Speed mode	rpm
Used to set the speed value of internal speed instruction 4.							

P01-27	Parameter name	Setting method	Effective time	Default	Range	Category	Unit
	Internal speed Instruction 5	Operation setting	Effective immediately	0	-5000 to 5000	Speed mode	rpm
Used to set the speed value of internal speed instruction 5.							

P01-28	Parameter name	Setting method	Effective time	Default	Range	Category	Unit
	Internal speed Instruction 6	Operation setting	Effective immediately	0	-5000 to 5000	Speed mode	rpm
Used to set the speed value of internal speed instruction 6.							

P01-29	Parameter name	Setting method	Effective time	Default	Range	Category	Unit
	Internal speed Instruction 7	Operation setting	Effective immediately	0	-5000 to 5000	Speed mode	rpm
Used to set the speed value of internal speed instruction 7.							

P01-30	Parameter name	Setting method	Effective time	Default	Range	Category	Unit
	Delay from brake output ON to instruction reception	Operation setting	Effective immediately	250	0 to 500	-	rpm
Set the delay time from the brake (BRK-OFF) output is ON to the servo drive allows to start receiving input instructions. When the brake output (BRK-OFF) is not allocated, this function code has no effect. Please refer to 6.1.8 Brake device .							

P01-31	Parameter name	Setting method	Effective time	Default	Range	Category	Unit
	Stationary state. delay from the brake output is OFF to the motor is not energized	Operation setting	Effective immediately	150	1 to 1000	-	rpm
When the motor is in a static state, set the delay time from the brake (BRK-OFF) output is OFF to the servo drive is in the non-powered state. When the brake output (BRK-OFF) is not allocated, this function code has no effect. Please refer to 6.1.8 Brake device .							

P01-32	Parameter name	Setting method	Effective time	Default	Range	Category	Unit
	Rotation state, when the brake output is OFF, the speed threshold	Operation setting	Effective immediately	30	0 to 3000	-	rpm
The motor is rotating, the motor speed threshold when the brake (BRK-OFF) is allowed to output OFF. When the brake output (BRK-OFF) is not allocated, this function code has no effect. Please refer to 6.1.8 Brake device .							

P01-33	Parameter name	Setting method	Effective time	Default	Range	Category	Unit
	Rotation status, delay from servo enable OFF to brake output OFF	Operation setting	Effective immediately	500	1 to 1000	-	rpm
The motor is rotating, the delay time from the brake (BRK-OFF) output OFF is allowed to the servo enable (S-ON) OFF. When the brake output (BRK-OFF) is not allocated, this function code has no effect. Please refer to 6.1.8 Brake device .							

P01-37	Parameter name	Setting method	Effective time	Default	Range	Category	Unit
	JOG acceleration time	Operation setting	Effective immediately	500	1 to 5000	-	ms

The time for JOG instruction to accelerate from 0 to 1000rpm.
Note: VD2L does not support DI control JOG function for the time being, but the JOG function of VD2L supports P1-37 and P1-38 parameters.

P01-38	Parameter name	Setting method	Effective time	Default	Range	Category	Unit
	JOG deceleration time	Operation setting	Effective immediately	500	1 to 5000	-	ms

Time for a JOG instruction to decelerate from 100rpm to 0.
Note: VD2L does not support DI control JOG function for the time being, but the JOG function of VD2L supports P1-37 and P1-38 parameters.

Group P02 Gain adjustment

P02-01	Parameter name	Setting method	Effective time	Default	Range	Category	Unit
	1st position loop gain	Operation setting	Effective immediately	232	0 to 6200	Gain control	0.1Hz

Set the proportional gain of the 1st position loop to determine the responsiveness of position control system.

P02-02	Parameter name	Setting method	Effective time	Default	Range	Category	Unit
	1st speed loop gain	Operation setting	Effective immediately	200	0 to 252	Gain control	0.1Hz

Set the proportional gain of the 1st speed loop to determine the responsiveness of speed loop.

P02-03	Parameter name	Setting method	Effective time	Default	Range	Category	Unit
	1st speed loop integral time constant	Operation setting	Effective immediately	210	100 to 65535	Gain control	0.1ms

Set the 1st speed loop integral constant. The smaller the set value, the stronger the integral effect.

P02-04	Parameter name	Setting method	Effective time	Default	Range	Category	Unit
	2nd position loop gain	Operation setting	Effective immediately	35	0 to 6200	Gain control	0.1Hz

Set the proportional gain of the 2nd position loop to determine the responsiveness of position control system.

P02-05	Parameter name	Setting method	Effective time	Default	Range	Category	Unit
	2nd speed loop gain	Operation setting	Effective immediately	65	0 to 35000	Gain control	0.1Hz

Set the proportional gain of the 2nd speed loop to determine the responsiveness of speed loop.

P02-06	Parameter name	Setting method	Effective time	Default	Range	Category	Unit
	2nd speed loop integral time constant	Operation setting	Effective immediately	1000	100 to 65535	Gain control	0.1ms

Set the 2nd speed loop integral constant. The smaller the set value, the stronger the integral effect.

P02-07	Parameter name	Setting method	Effective time	Default	Range	Category	Unit
--------	----------------	----------------	----------------	---------	-------	----------	------

2nd gain switching mode	Operation setting	Effective immediately	1	0 to 1	Gain control	-
Used to set the 2nd gain switching mode.						
		Setting value	Definition			
		0	First gain fixed. Use DI function 10 (GAIN-SEL) to switch: DI logic invalid: PI control; DI logic valid: P control.			
		1	Switch first gain and second gain by the setting value of P02-08.			

P02-08	Parameter name	Setting method	Effective time	Default	Range	Category	Unit
	Gain switching condition selection	Operation setting	Effective immediately	0	0 to 10	Gain control	
Set the conditions for gain switching.							
		Setting value	Gain switching conditions	Details			
		0	The default is the first gain	Fixed use of the first gain			
		1	Switch by DI port	Use DI function 10 (GAIN-SEL, gain switching); DI logic is invalid: the first gain (P02-01~P02-03); DI logic is valid: the second gain (P02-04~P02-06).			
		2	Large torque command	In the previous first gain, when the absolute value of torque command is greater than (grade + hysteresis), the second gain is switched; In the previous second gain, when the absolute value of torque command is less than the value of (grade - hysteresis) and the duration is greater than [P02-13], the first gain is returned.			
		3	Large actual torque	In the previous first gain, when the absolute value of actual torque is greater than (grade + hysteresis), the second gain is switched; In the previous second gain, when the absolute value of actual torque is less than the value of (grade - hysteresis) and the duration is greater than [P02-13], the first gain is returned.			
		4	Large speed command	In the previous first gain, when the absolute value of speed command is greater than (grade + hysteresis), the second gain is switched; In the previous second gain, when the absolute value of speed command is less than the value of (grade - hysteresis) and the duration is greater than [P02-13], the first gain is returned.			
		5	Large actual speed	In the previous first gain, when the absolute value of actual speed is greater than (grade + hysteresis), the second gain is switched; In the previous second gain, when the absolute value of actual speed is less than the value of (grade - hysteresis) and the duration is greater than [P02-13], the first gain is returned.			

6	Large rate of change in speed command	In the previous first gain, when the absolute value of the rate of change in speed command is greater than (grade + hysteresis), the second gain is switched; In the previous second gain, switch to the first gain when the absolute value of the rate of change in speed command is less than the value of (grade - hysteresis) and the duration is greater than [P02-13], the first gain is returned.
7	Large position deviation	In the previous first gain, when the absolute value of position deviation is greater than (grade + hysteresis), the second gain is switched; In the previous second gain, switch to the first gain when the absolute value of position deviation is less than the value of (grade - hysteresis) and the duration is greater than [P02-13], the first gain is returned.
8	Position command	In the previous first gain, if the position command is not 0, switch to the second gain; In the previous second gain, if the position command is 0 and the duration is greater than [P02-13], the first gain is returned.
9	Positioning complete	In the previous first gain, if the positioning is not completed, the second gain is switched; In the previous second gain, if the positioning is not completed and the duration is greater than [P02-13], the first gain is returned.
10	Position command + actual speed	In the previous first gain, if the position command is not 0, the second gain is switched; In the previous second gain, if the position command is 0, the duration is greater than [P02-13] and the absolute value of actual speed is less than (grade - hysteresis).

	Parameter name	Setting method	Effective time	Default	Range	Category	Unit
P02-09	Speed feedforward gain	Operation setting	Effective immediately	0	0 to 1000	Gain control	0.1%
Set speed feedforward gain							

	Parameter name	Setting method	Effective time	Default	Range	Category	Unit
P02-10	Speed feedforward filtering time constant	Operation setting	Effective immediately	50	0 to 10000	Gain control	0.01 ms
Set the time constant of one delay filter related to the speed feedforward input.							

	Parameter name	Setting method	Effective time	Default	Range	Category	Unit
P02-11	Torque feedforward gain	Operation setting	Effective immediately	0	0 to 2000	Gain control	0.1%
Set torque feedforward gain							

	Parameter name	Setting method	Effective time	Default	Range	Category	Unit
P02-12	Torque feedforward filter time constant	Operation setting	Effective immediately	50	0 to 10000	Gain control	0.01 ms
Set the time constant of one delay filter related to the torque feedforward input.							

P02-13	Parameter name	Setting method	Effective time	Default	Range	Category	Unit
---------------	----------------	----------------	----------------	---------	-------	----------	------

	Delay Time for Gain Switching	Operation setting	Effective immediately	20	0 to 10000	Gain control	0.1ms
--	-------------------------------	-------------------	-----------------------	----	------------	--------------	-------

The duration of the switching condition required for the second gain to switch back to the first gain.

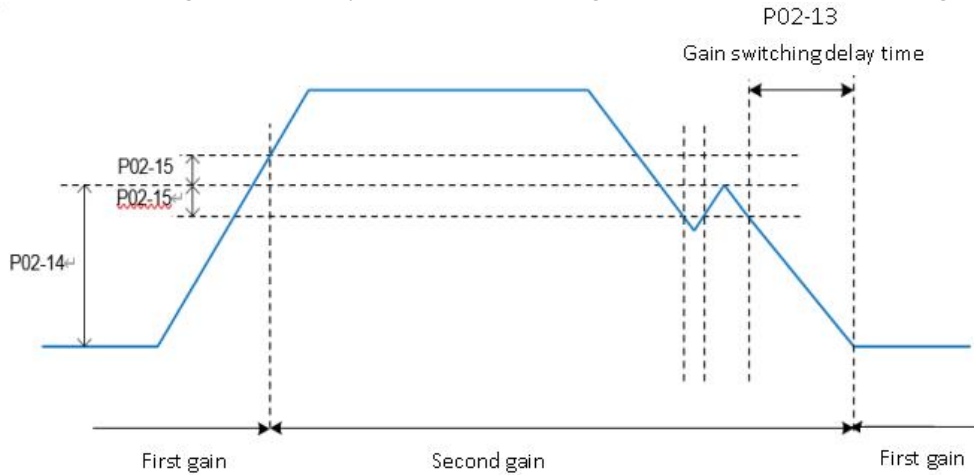

Note: This parameter is only valid when the second gain is switched back to the first gain.

	Parameter name	Setting method	Effective time	Default	Range	Category	Unit
P02-14	Gain switching grade	Operation setting	Effective immediately	50	0 to 20000	Gain control	According to the switching conditions

Set the grade of the gain condition. The generation of the actual switching action is affected by the two conditions of grade and hysteresis.

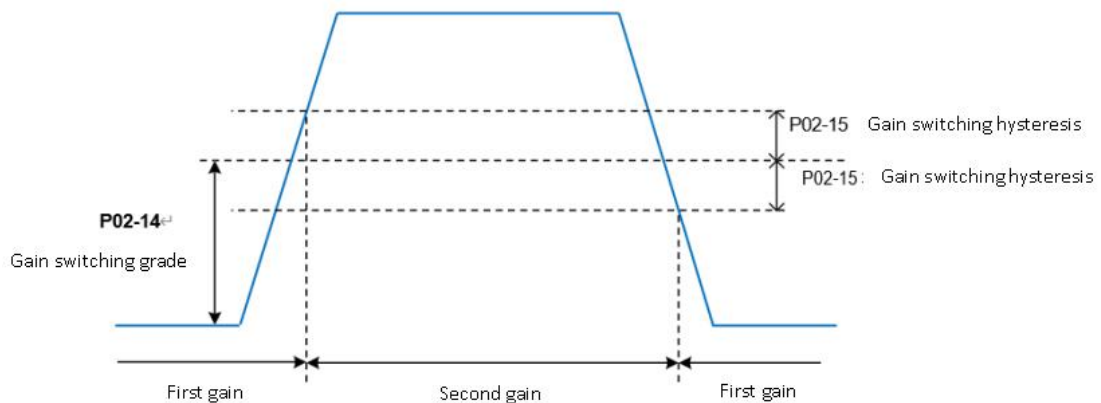

	Parameter name	Setting method	Effective time	Default	Range	Category	Unit
P02-15	Gain switching hysteresis	Operation setting	Effective immediately	20	0 to 20000	Gain control	According to the switching conditions

Set the hysteresis to meet the gain switching condition.

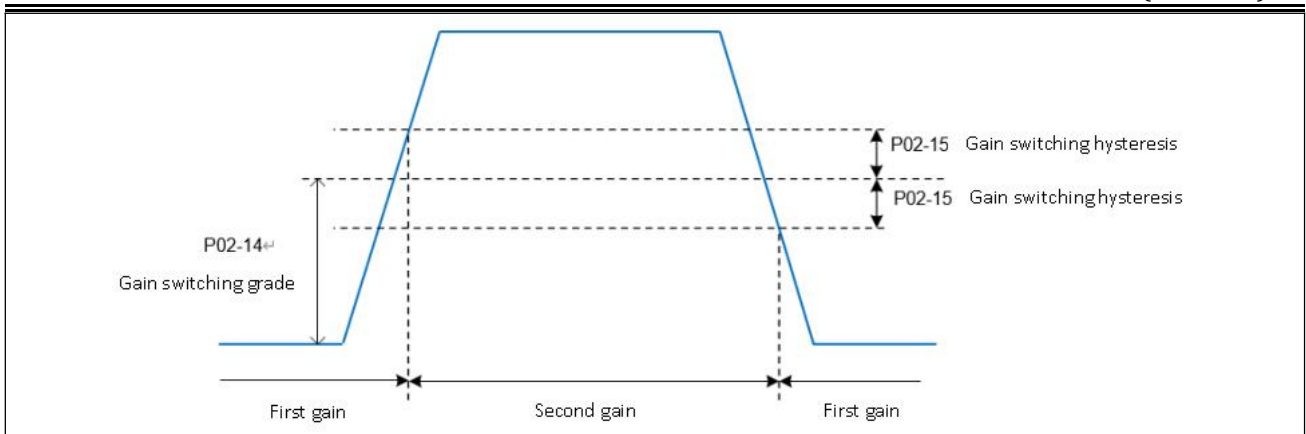

Parameter name	Setting method	Effective time	Default	Range	Category	Unit
P02-16 Position loop gain switching time	Operation setting	Effective immediately	30	0 to 10000	Gain control	0.1ms

Set the time for switching from the first position loop (P02-01) to the second position loop (P02-04) in the position control mode.

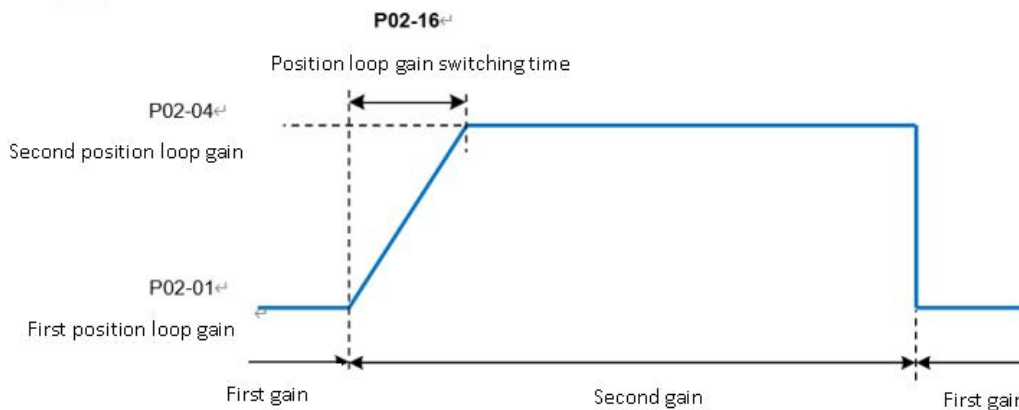

If $P02-04 \leq P02-01$, then P02-16 is invalid, and the second gain is switched from the first gain immediately.

Parameter name	Setting method	Effective time	Default	Range	Category	Unit
P02-20 Enable model tracking control function	Shutdown setting	Effective immediately	0	0 to 1	Gain control	

Set 1 to enable the model tracking control function.

Parameter name	Setting method	Effective time	Default	Range	Category	Unit
P02-21 Model tracking control gain	Shutdown setting	Effective immediately	1000	200 to 20000	Gain control	0.1/s

Increasing the model tracking control gain can improve the position response performance of the model loop. If the gain is too high, it may cause overshoot behavior.

Parameter name	Setting method	Effective time	Default	Range	Category	Unit
P02-22 Model tracking control gain compensation	Shutdown setting	Effective immediately	1000	500 to 2000	Gain control	0.10%

The gain compensation affects the damping ratio of the model loop, and the damping ratio becomes larger as the gain compensation becomes larger.

Parameter name	Setting method	Effective time	Default	Range	Category	Unit
P02-23 Model tracking control forward rotation bias	Operation setting	Effective immediately	1000	0 to 10000	Gain control	0.10%

Torque feedforward size in the positive direction under model tracking control.

	Parameter name	Setting method	Effective time	Default	Range	Category	Unit
P02-24	Model tracking control reverses rotation bias	Operation setting	Effective immediately	1000	0 to 10000	Gain control	0.10%
Torque feedforward size in the reverse direction under model tracking control.							

	Parameter name	Setting method	Effective time	Default	Range	Category	Unit
P02-25	Model tracking control speed feedforward compensation	Operation setting	Effective immediately	1000	0 to 10000	Gain control	0.10%
The size of the speed feedforward under model tracking control.							

Group P03 Self-adjusting parameters

P03-01	Parameter name	Setting method	Effective time	Default	Range	Category	Unit
	Load inertia ratio	Operation setting	Effective immediately	300*	100 to 10000	Self-tuning	0.01

Set load inertia ratio: 0.00 to 100.00 times.
 “*” indicates that the factory defaults for different models may differ.

P03-02	Parameter name	Setting method	Effective time	Default	Range	Category	Unit
	Load rigidity grade selection	Operation setting	Effective immediately	14*	0 to 31	Self-tuning	-

Set the rigidity of servo system. The higher the value, the faster the response, but too high rigidity will cause vibration. “*” indicates that the factory defaults for different models may differ.

P03-03	Parameter name	Setting method	Effective time	Default	Range	Category	Unit
	Self-adjusting mode selection	Operation setting	Effective immediately	0	0 to 2	Self-tuning	-

Different gain adjustment modes could be set, and the relevant gain parameters could be set manually or automatically set according to the rigidity level table.

Setting value	Instruction source	Remarks
0	Self-adjusting mode.	Position loop gain, speed loop gain, speed loop integral time constant, torque filter parameter settings are automatically adjusted according to the rigidity grade setting.
1	Manual setting	You need to manually set the position loop gain, speed loop gain, speed loop integral time constant, torque filter parameter
2	Online automatic self-adjusting mode	Not implemented yet

P03-04	Parameter name	Setting method	Effective time	Default	Range	Category	Unit
	Online inertia recognition sensitivity	Operation setting	Effective immediately	0	0 to 2	Self-tuning	-

Not implemented yet.

P03-05	Parameter name	Setting method	Effective time	Default	Range	Category	Unit
	Number of circles Inertia recognition	Shutdown setting	Effective immediately	2	1 to 20	Self-tuning	Circle

Offline load inertia recognition process, motor rotation number setting

P03-06	Parameter name	Setting method	Effective time	Default	Range	Category	Unit
	Inertia recognition maximum speed	Shutdown setting	Effective immediately	1000	300 to 2000	Self-tuning	rpm

Set the allowable maximum motor speed instruction in offline inertia recognition mode. The faster the speed during inertia recognition, the more accurate the recognition result will be. You are advised to keep the default value.

P03-07	Parameter name	Setting method	Effective time	Default	Range	Category	Unit
	Parameter recognition rotation direction	Shutdown setting	Effective immediately	0	0 to 2	Self-tuning	-

Set parameter recognition rotation direction

Setting value	Rotation direction
0	Forward and reverse reciprocating rotation
1	Forward one-way rotation
2	Reverse one-way rotation

	Parameter name	Setting method	Effective time	Default	Range	Category	Unit
P03-08	Parameter recognition waiting time	Shutdown setting	Effective immediately	1000	300 to 10000	Self-tuning	ms
During offline inertia recognition, the time interval between two consecutive speed instructions							

Group P04 Vibration suppression

P04-01	Parameter name	Setting method	Effective time	Default	Range	Category	Unit
	Pulse instruction filtering method	Shutdown setting	Effective immediately	0	0 to 1	Position mode	-
		Setting value	Filtering method				
		0	First-order low-pass filter				
		1	Average filtering				

P04-02	Parameter name	Setting method	Effective time	Default	Range	Category	Unit
	Position instruction first-order low-pass filtering time constant	Shutdown setting	Effective immediately	0	0 to 1000	Position mode	ms

Used to set position instructions first-order low-pass filtering time constant.

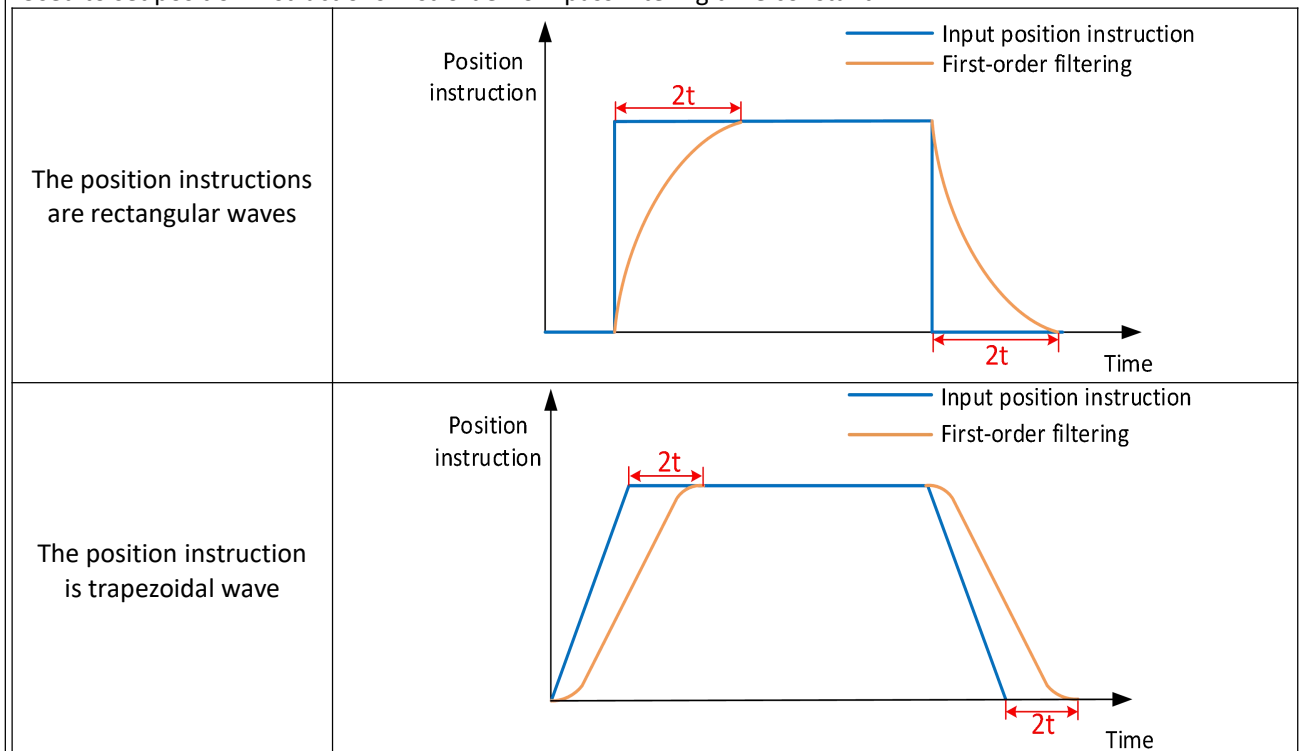

	Parameter name	Setting method	Effective time	Default	Range	Category	Unit
P04-03	Position instruction average filtering time constant	Shutdown setting	Effective immediately	0	0 to 128	Position mode	ms

Used to set average filtering time constant.

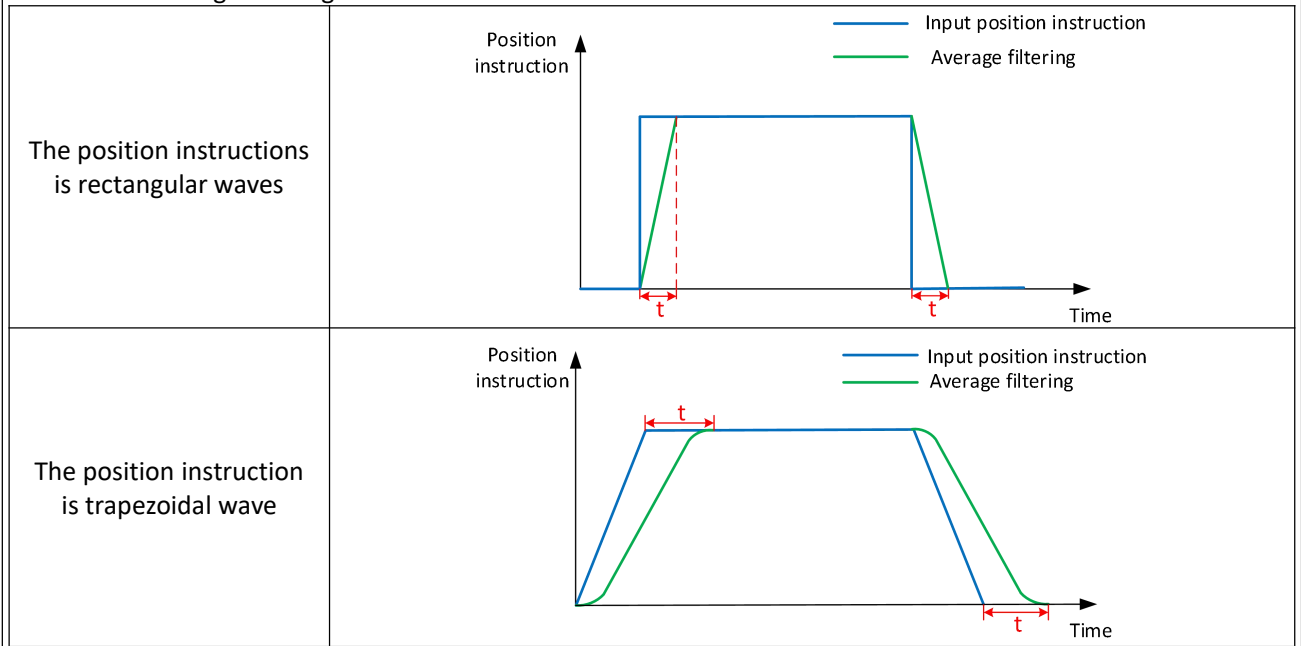

	Parameter name	Setting method	Effective time	Default	Range	Category	Unit
P04-04	Torque filtering time constant	Operation setting	Effective immediately	80	10 to 2500	Vibration suppression	0.01ms

Used to set torque filtering time constant. When the function code P03-03(Self-adjustment mode selection) is set to 0, the parameter is automatically set by servo. Please refer to [6.4.2 Torque instruction filtering](#)

	Parameter name	Setting method	Effective time	Default	Range	Category	Unit
P04-05	1st notch filter frequency	Operation setting	Effective immediately	300	250 to 5000	Vibration suppression	Hz

Set the center frequency of the 1st notch filter.

When the function code is set to 5000, the function of the notch filter is invalid.

	Parameter name	Setting method	Effective time	Default	Range	Category	Unit
P04-06	1st notch filter depth	Operation setting	Effective immediately	100	0 to 100	Vibration suppression	-

Set the notch filter depth grade (the ratio between input and output at the center frequency of the notch filter) The larger the set value of this function code is, the smaller the notch filter depth is, and the weaker the suppression effect of mechanical vibration is. However, setting too large could cause system instability. Please refer to [7.4.2 Notch filter](#)

	Parameter name	Setting method	Effective time	Default	Range	Category	Unit
P04-07	1st notch filter width	Operation setting	Effective immediately	4	0 to 12	Vibration suppression	-

Set the notch filter width grade (the ratio between input and output at the center frequency of the notch filter)

	Parameter name	Setting method	Effective time	Default	Range	Category	Unit
P04-08	2nd notch filter frequency	Operation setting	Effective immediately	500	250 to 5000	Vibration suppression	Hz

Set the center frequency of the 1st notch filter.

When the function code is set to 5000, the function of the notch filter is invalid.

	Parameter name	Setting method	Effective time	Default	Range	Category	Unit
P04-09	2nd notch filter depth	Operation setting	Effective immediately	100	0 to 100	Vibration suppression	-

	Parameter name	Setting method	Effective time	Default	Range	Category	Unit
P04-10	2nd notch filter width	Operation setting	Effective immediately	4	0 to 12	Vibration suppression	-

	Parameter name	Setting method	Effective time	Default	Range	Category	Unit
P04-11 ○	Enable low-frequency vibration suppression function	Operation setting	Effective immediately	0	0 to 1	Vibration suppression	

When the function code is set to 1, enable the low-frequency vibration suppression function.

	Parameter name	Setting method	Effective time	Default	Range	Category	Unit
P04-12 ○	Low-frequency vibration suppression frequency	Operation setting	Effective immediately	800	10 to 2000	Vibration suppression	0.1HZ

Set the vibration frequency when vibration occurs at the load end.

	Parameter name	Setting method	Effective time	Default	Range	Category	Unit
P04-14 ○	Shutdown vibration detection amplitude	Operation setting	Effective immediately	100	0 to 3000	Vibration suppression	0.001

When the vibration amplitude is greater than detection amplitude ratio, the low-frequency vibration frequency can be recognized and updated to the U0-16 monitor quantity. The function code is set too large or too small to affect the recognition of the vibration frequency.

	Parameter name	Setting method	Effective time	Default	Range	Category	Unit
P04-18 ○	Speed feedback filtering time	Operation setting	Effective immediately	40	20 to 1000	Vibration suppression	0.01ms

Wave filtering of the feedback speed of the encoder. When the filtering time is set large, it may cause the motor to vibrate.

	Parameter name	Setting method	Effective time	Default	Range	Category	Unit
P04-19 ○	Enable the type A suppression function	Operation setting	Effective immediately	0	0 to 1	Vibration suppression	

When the function code is set to 1, enable the type A suppression function.

	Parameter name	Setting method	Effective time	Default	Range	Category	Unit
P04-20 ○	Type A suppression frequency	Operation setting	Effective immediately	1000	100 to 20000	Vibration suppression	0.1HZ

Set the frequency of Type A suppression.

	Parameter name	Setting method	Effective time	Default	Range	Category	Unit
P04-21 ○	Type A suppression gain correction	Operation setting	Effective immediately	100	0 to 1000	Vibration suppression	0.01
Correct the load inertia ratio size.							

	Parameter name	Setting method	Effective time	Default	Range	Category	Unit
P04-22 ○	Type A suppression damping gain	Operation setting	Effective immediately	0	0 to 500	Vibration suppression	0.01
The type A rejection compensation value is gradually increased until the vibration is reduced to the acceptable range.							

	Parameter name	Setting method	Effective time	Default	Range	Category	Unit
P04-23 ○	Type A suppression phase correction	Operation setting	Effective immediately	200	0 to 900	Vibration suppression	0.1 degree
Type A suppression phase compensation.							

Group P05 Signal input and output

P05-01	Parameter name	Setting method	Effective time	Default	Range	Category	Unit
★	AI_1 input bias	Operation setting	Effective immediately	0	-5000 to 5000	Analog input	mV

Set AI_1 channel analog bias value

“★” indicates that the VD2F servo drive does not support this function code.

P05-02	Parameter name	Setting method	Effective time	Default	Range	Category	Unit
★	AI_1 input filter time constant	Operation setting	Effective immediately	200	0 to 60000	Analog input	0.01ms

Set AI_1 channel input first-order low-pass filter time constant

“★” indicates that the VD2F servo drive does not support this function code.

P05-03	Parameter name	Setting method	Effective time	Default	Range	Category	Unit
★	AI_1 dead zone	Operation setting	Effective immediately	20	0 to 1000	Analog input	mV

Set AI_1 channel analog quantity dead zone value. “Dead zone” is the input voltage interval when the sample voltage is 0.

“★” indicates that the VD2F servo drive does not support this function code.

P05-04 ★	Parameter name	Setting method	Effective time	Default	Range	Category	Unit
	AI_1 zero drift	Operation setting	Effective immediately	0	-500 to 500	Analog input	mV

Set the zero drift of AI_1 channel analog. "zero drift" is the sample voltage co voltage relative to GND when analog channel voltage is 0.

P05-05 ★	Parameter name	Setting method	Effective time	Default	Range	Category	Unit
	AI_2 input bias	Operation setting	Effective immediately	0	-5000 to 5000	Analog input	mV

P05-06 ★	Parameter name	Setting method	Effective time	Default	Range	Category	Unit
	AI_2 input filter time constant	Operation setting	Effective immediately	200	0 to 60000	Analog input	0.01ms

P05-07 ★	Parameter name	Setting method	Effective time	Default	Range	Category	Unit
	AI_2 dead zone	Operation setting	Effective immediately	20	0 to 500	Analog input	mV

P05-08 ★	Parameter name	Setting method	Effective time	Default	Range	Category	Unit
	AI_2 zero drift	Operation setting	Effective immediately	0	-500 to 500	Analog input	mV

P05-09 ★	Parameter name	Setting method	Effective time	Default	Range	Category	Unit
	Analog 10V corresponds to the speed value	Shutdown setting	Effective immediately	3000	100 to 4500	Analog input	rpm

Set the speed value corresponding to the analog 10V

Mode	Function code value	Sampling voltage and speed diagram
Speed mode	P01-01=1	

Given speed = sampling voltage / 10 * (P05-09)

★: Indicates that neither VD2F nor VD2L servo drivers support this function code

	Parameter name	Setting method	Effective time	Default	Range	Category	Unit
P05-10 ★	Analog 10V corresponds to the torque value	Shutdown setting	Effective immediately	1000	0 to 3000	Analog input	0.1%

Set the torque value corresponding to the analog 10V

Mode	Function code value	Sampling voltage and speed diagram
Torque mode	P01-07=1	

Given torque= sampling voltage / 10 * (P05-09)

	Parameter name	Setting method	Effective time	Default	Range	Category	Unit
P05-11	Positioning completion, positioning approach condition setting	Operation setting	Effective immediately	0	0 to 3	Position mode	-

Set the conditions of setting positioning completion and positioning approach. When servo is in position mode, and the absolute value of the positional deviation is within the range of P05-12 (positioning complete threshold) or P05-13 (positioning approach threshold), servo would output the positioning complete signal and positioning approach signal.

Set value	Output condition
0	It is valid when the absolute value of the position deviation is smaller than or close to the threshold
1	It is valid when the absolute value of the position deviation is smaller than or close to the threshold and input position instruction is 0
2	It is valid when the absolute value of the position deviation is smaller than or close to the threshold and input position instruction filtering value is 0
3	It is valid when the absolute value of the position deviation is smaller than or close to the threshold, input position instruction filtering value is 0, and continuous positioning detects window time

Given torque= sampling voltage / 10 * (P05-09)

	Parameter name	Setting method	Effective time	Default	Range	Category	Unit
P05-12	Positioning completion threshold	Operation setting	Effective immediately	800	1 to 65535	Position mode	Equivalent pulse unit

Set the threshold of absolute value of position deviation when servo drive output positioning completion signal

	Parameter name	Setting method	Effective time	Default	Range	Category	Unit
P05-13	Positioning approach threshold	Operation setting	Effective immediately	5000	1 to 65535	Position mode	Equivalent pulse unit

Set the threshold of absolute value of position deviation when servo drive output positioning approach signal

“★” indicates that the VD2F servo drive does not support this function code.

	Parameter name	Setting method	Effective time	Default	Range	Category	Unit
P05-14	Position detection window time	Operation setting	Effective immediately	10	0 to 20000	Position mode	ms
	Set the detection window time for positioning completion						

	Parameter name	Setting method	Effective time	Default	Range	Category	Unit
P05-15	Positioning signal holding time	Operation setting	Effective immediately	100	0 to 20000	Position mode	ms
	Set the time for the signal to remain in effect after positioning when P05-11=3 (Positioning completion and positioning approach condition setting)						

	Parameter name	Setting method	Effective time	Default	Range	Category	Unit
P05-16	Rotation detection speed threshold	Operation setting	Effective immediately	20	0 to 1000	Speed mode	rpm
	Set the speed threshold that triggers the motor rotation signal. The motor rotation signal (TGON) is used to confirm that the motor has rotated. Please refer to 6.3.5 Speed-related DO output function						

	Parameter name	Setting method	Effective time	Default	Range	Category	Unit
P05-17	Speed consistent signal threshold	Operation setting	Effective immediately	10	0 to 100	Speed mode	rpm
	Set the speed threshold that triggers the motor speed consistent signal. The motor outputs speed consistent signal (V-COIN) indicates that the actual speed has reached the speed instruction setting value. Please refer to 6.3.5 Speed-related DO output function						

	Parameter name	Setting method	Effective time	Default	Range	Category	Unit
P05-18	Speed approach signal threshold	Operation setting	Effective immediately	100	10 to 6000	Speed mode	rpm
	Set the speed threshold that triggers the motor speed approach signal. The motor outputs speed approach signal (V-NEAR) indicates that the actual speed has reached the expected value. Please refer to 6.3.5 Speed-related DO output function						

	Parameter name	Setting method	Effective time	Default	Range	Category	Unit
P05-19	Zero speed output signal threshold	Operation setting	Effective immediately	10	0 to 6000	Speed mode	rpm
	Set the speed threshold that triggers the motor zero speed output signal. The motor outputs zero speed signal (ZSP) indicates that the actual speed is almost stationary. Please refer to 6.3.5 Speed-related DO output function						

	Parameter name	Setting method	Effective time	Default	Range	Category	Unit
P05-20	Torque arrival threshold	Operation setting	Effective immediately	100	0 to 300	Torque mode	%
	Please refer to 6.4.5 Torque-related DO output functions						

	Parameter name	Setting method	Effective time	Default	Range	Category	Unit
P05-21	Torque arrival hysteresis value	Operation setting	Effective immediately	10	0 to 20	Torque mode	%
	Please refer to 6.4.5 Torque-related DO output functions						

Group P06 DI/DO configuration

Parameter name	Setting method	Effective time	Default	Range	Category	Unit
P06-02 DI_1 channel function selection	Operation setting	Power on again	1	0 to 32	DI/DO	-

Set DI functions corresponding to hardware DI_1. The related functions are as below.

Set value	DI channel function	Set value	DI channel function
0	Off (not used)	13	INSPD1 (Internal speed instruction selection 1)
1	S-ON (Servo enable)	14	INSPD2 (Internal speed instruction selection 2)
2	A-CLR (Fault and warning clear)	15	INSPD3 (Internal speed instruction selection 3)
3	POT (Forward drive prohibition)	16	J-SEL Inertia ratio switch (not implemented yet)
4	NOT (Reverse drive prohibition)	17	MixModeSel Mix mode selection
5	ZCLAMP (Zero-speed clamp)	18	None
6	CL (Clear deviation counter)	19	None
7	C-SIGN (instruction is reversed)	20	ENINPOS (Internal multi-segment enable signal)
8	E-STOP (Emergency stop)	21	INPOS1 (Internal multi-segment position selection 1)
9	GEAR-SEL (Electronic Gear Switch 1)	22	INPOS2 (Internal multi-segment position selection 2)
10	GAIN-SEL (Gain switch)	23	INPOS3 (Internal multi-segment position selection 3)
11	INH (Instruction pulse prohibited input)	24	INPOS4 (Internal multi-segment position selection 4)
12	VSSEL (Vibration control switching input)	-	-

If P06-02 is set to a value other than that in the preceding table, the DI port function is not require

The same DI channel function could not be allocated to multiple DI ports, otherwise servo drive will occur A-89 (DI port configuration duplication)

Parameter name	Setting method	Effective time	Default	Range	Category	Unit
P06-03 DI_1 channel logic selection	Operation setting	Effective immediately	0	0 to 1	DI/DO	-

DI port input logic validity function selection

Set value	Content	Illustration
0	Normally open input. Active low level (switch on)	
1	Normally closed input. Active high level (switch off)	

Parameter name	Setting method	Effective time	Default	Range	Category	Unit
P06-04 DI_1 input source selection	Operation setting	Effective immediately	0	0 to 1	DI/DO	-

Select the enabled DI_1 port type

Set value	Content
0	Hardware DI_1 input terminal
1	Virtual VDI_1 input terminal

	Parameter name	Setting method	Effective time	Default	Range	Category	Unit
P06-05	DI_2 channel function selection	Operation setting	Power on again	2	0 to 32	DI/DO	-
P06-06	DI_2 channel logic selection	Operation setting	Effective immediately	0	0 to 1	DI/DO	-
P06-07	DI_2 input source selection	Operation setting	Effective immediately	0	0 to 1	DI/DO	-
P06-08	DI_3 channel function selection	Operation setting	Power on again	3	0 to 32	DI/DO	-
P06-09	DI_3 channel logic selection	Operation setting	Effective immediately	0	0 to 1	DI/DO	-
P06-10	DI_3 input source selection	Operation setting	Effective immediately	0	0 to 1	DI/DO	-
P06-11	DI_4 channel function selection	Operation setting	Power on again	4	0 to 32	DI/DO	-
P06-12	DI_4 channel logic selection	Operation setting	Effective immediately	0	0 to 1	DI/DO	-
P06-13	DI_4 input source selection	Operation setting	Effective immediately	0	0 to 1	DI/DO	-
P06-14 ★	DI_5 channel function selection	Operation setting	Power on again	7	0 to 32	DI/DO	-
P06-15 ★	DI_5 channel logic selection	Operation setting	Effective immediately	0	0 to 1	DI/DO	-
P06-16 ★	DI_5 input source selection	Operation setting	Effective immediately	0	0 to 1	DI/DO	-
P06-17 ★	DI_6 channel function selection	Operation setting	Power on again	11	0 to 32	DI/DO	-

“★” indicates that the VD2F servo drive does not support this function code.

P06-18 ★	Parameter name	Setting method	Effective time	Default	Range	Category	Unit
	DI_6 channel logic selection	Operation setting	Effective immediately	0	0 to 1	DI/DO	-

P06-19 ★	Parameter name	Setting method	Effective time	Default	Range	Category	Unit
	DI_6 input source selection	Operation setting	Effective immediately	0	0 to 1	DI/DO	-

P06-20 ★	Parameter name	Setting method	Effective time	Default	Range	Category	Unit
	DI_7 channel function selection	Operation setting	Power on again	2	0 to 32	DI/DO	-

P06-21 ★	Parameter name	Setting method	Effective time	Default	Range	Category	Unit
	DI_7 channel logic selection	Operation setting	Power on again	0	0 to 1	DI/DO	-

P06-22 ★	Parameter name	Setting method	Effective time	Default	Range	Category	Unit
	DI_7 input source selection	Operation setting	Effective immediately	0	0 to 1	DI/DO	-

P06-23 ★	Parameter name	Setting method	Effective time	Default	Range	Category	Unit
	DI_8 channel function selection	Operation setting	Power on again	0	0 to 32	DI/DO	-

P06-24 ★	Parameter name	Setting method	Effective time	Default	Range	Category	Unit
	DI_8 channel logic selection	Operation setting	Power on again	0	0 to 1	DI/DO	-

P06-25 ★	Parameter name	Setting method	Effective time	Default	Range	Category	Unit
	DI_8 input source selection	Operation setting	Effective immediately	0	0 to 1	DI/DO	-

P06-26	Parameter name	Setting method	Effective time	Default	Range	Category	Unit
	DO_1 channel function selection	Operation setting	Effective immediately	132	128 to 148	DI/DO	-

Set DO functions corresponding to hardware DO_1. The related functions are as below.

Set value	DO channel function	Set value	DO channel function
128	Close (not used)	139	T-LIMIT (Torque limit)
129	RDY (Servo ready)	140	V-LIMIT (speed limited)
130	ALM (fault signal)	141	BRK-OFF (brake output)
131	WARN (warning signal)	142	SRV-ST (Servo on state output)
132	TGON (rotation detection)	143	OZ (Z pulse output)
133	ZSP (zero speed signal)	144	None
134	P-COIN (positioning completed)	145	COM_VDO1 (communication VDO1 output)
135	P-NEAR (positioning approach)	146	COM_VDO2 (communication VDO2 output)
136	V-COIN (consistent speed)	147	COM_VDO3 (communication VDO3 output)
137	V-NEAR (speed approach)	148	COM_VDO4 (communication VDO4 output)
138	T-COIN (torque arrival)	-	

If P06-26 is set to a value other than that in the preceding table, the DO port function is not required. The same DO channel function could not be allocated to multiple DO ports, otherwise servo drive will occur A-90 (DO port configuration duplication).

means use the function code BRK-OFF would be effective after power on again.

Note: Only VD2F supports 143: OZ (Z pulse output). The function of VD2-0□□SA1G is empty.

“★” indicates that the VD2F servo drive does not support this function code.

P06-27	Parameter name	Setting method	Effective time	Default	Range	Category	Unit
	DO_1 channel logic selection	Operation setting	Effective immediately	0	0 to 1	DI/DO	-
DO Port input logic validity function selection.							
Set value	Content						
0	Output transistor is on when the output is valid, and output transistor is off when the output is invalid.						
1	Output transistor is off when the output is valid, and output transistor is on when the output is invalid.						

P06-28	Parameter name	Setting method	Effective time	Default	Range	Category	Unit
	DO_2 channel function selection	Operation setting	Effective immediately	130	128 to 148	DI/DO	-

P06-29	Parameter name	Setting method	Effective time	Default	Range	Category	Unit
	DO_2 channel logic selection	Operation setting	Effective immediately	0	0 to 1	DI/DO	-

P06-30	Parameter name	Setting method	Effective time	Default	Range	Category	Unit
	DO_3 channel function selection	Operation setting	Effective immediately	129	128 to 148	DI/DO	-

P06-31	Parameter name	Setting method	Effective time	Default	Range	Category	Unit
	DO_3 channel logic selection	Operation setting	Effective immediately	0	0 to 1	DI/DO	-

P06-32	Parameter name	Setting method	Effective time	Default	Range	Category	Unit
	DO_4 channel function selection	Operation setting	Effective immediately	134	128 to 148	DI/DO	-

P06-33	Parameter name	Setting method	Effective time	Default	Range	Category	Unit
	DO_4 channel logic selection	Operation setting	Effective immediately	0	0 to 1	DI/DO	-

Group P07 multi-segment position

P07-01	Parameter name	Setting method	Effective time	Default	Range	Category	Unit
	Multi-segment position operation mode	Shutdown setting	Effective immediately	0	0 to 2	-	-

When servo is in position mode, and P01-06 (position instruction source) =1, set the operation mode of multi-segment position

Set value	Operation mode	Remarks
0	Single running	Stop after running one round. The segment number automatic increment switching.
1	Cycle running	Cycle running. The segment number automatic increment switching.
2	DI switching running	Segment number updates can continue to run. The segment numbers are determined by the DI terminal logic

To use multi-segment position function, a DI port channel of servo drive should be configured to function 20 (ENINPOS, internal multi-segment position enabled signal), and the logic of the DI terminal valid should be confirmed. Please refer to [Group P06 DI/DO configuration](#)

P07-02	Parameter name	Setting method	Effective time	Default	Range	Category	Unit																														
	Starting position number	Shutdown setting	Effective immediately	1	1 to 16	-	-																														
Set the starting segment number in single running or cycle running. When P07-01≠2, the segment number automatic increment switching. When P07-01=2, 4 DI ports need be set to DI function 21 (INPOS1, internal multi-segment position segment selection 1 to INPOS4, internal multi-segment position segment selection 4), and the segment number is switched by the servo host computer to control the DI terminal logic. Multi-segment number is 4-bit binary number. The corresponding relations between internal multi-segment position segment selection and segment number are as below. If DI terminal logic is valid, the value of internal multi-segment position segment selection is 1, otherwise it is 0.																																					
<table border="1"> <thead> <tr> <th>INPOS4</th> <th>INPOS3</th> <th>INPOS2</th> <th>INPOS1</th> <th>Operation segment number</th> </tr> </thead> <tbody> <tr> <td>0</td> <td>0</td> <td>0</td> <td>0</td> <td>1</td> </tr> <tr> <td>0</td> <td>0</td> <td>0</td> <td>1</td> <td>2</td> </tr> <tr> <td>0</td> <td>0</td> <td>1</td> <td>0</td> <td>3</td> </tr> <tr> <td colspan="5" style="text-align: center;">.....</td> </tr> <tr> <td>1</td> <td>1</td> <td>1</td> <td>1</td> <td>16</td> </tr> </tbody> </table>								INPOS4	INPOS3	INPOS2	INPOS1	Operation segment number	0	0	0	0	1	0	0	0	1	2	0	0	1	0	3					1	1	1	1	16
INPOS4	INPOS3	INPOS2	INPOS1	Operation segment number																																	
0	0	0	0	1																																	
0	0	0	1	2																																	
0	0	1	0	3																																	
.....																																					
1	1	1	1	16																																	

P07-03	Parameter name	Setting method	Effective time	Default	Range	Category	Unit
	End position number	Shutdown setting	Effective immediately	1	1 to 16	-	-
Set the end segment number in single running or cycle running. When P07-01≠2, the segment number automatic increment switching. The switching sequence is: P07-02,, P07-03.							

P07-04	Parameter name	Setting method	Effective time	Default	Range	Category	Unit
	Margin handling method	Shutdown setting	Effective immediately	0	0 to 1	-	-
The starting segment number used for the servo drive will run when it resumes after pausing in multi-segment. "Pause" indicates that internal multi-segment position enable signal changes from valid to invalid.							
	Set value	Margin handling method	Remarks				
	0	Run the remaining positions	If P07-03 (end segment number) =16, servo would stop running in the 2nd segment. After restoring the "Internal Multi-Segment Enable Signal", servo would run from the 3rd segment.				
	1	Run again from the starting position	If P07-02 (start segment number) =1, and P07-03 (end segment number) =16, servo would stop running in the 2nd segment. After restoring the "Internal Multi-Segment Enable Signal", servo would run from the set value of P07-02				
Once paused during multi-segment position operation, the servo drive will abandon the unfinished position instructions in this segment and shutdown. Please refer to Margin handling method							

P07-05	Parameter name	Setting method	Effective time	Default	Range	Category	Unit
	Displacement instruction type	Shutdown setting	Effective immediately	0	0 to 1	-	-
Set the displacement instruction type of multi-segment position function. "Displacement instruction" is the sum of the displacement instructions over a period of time.							
	Set value	Instruction type	Remarks				
	0	Relative position instruction	Relative displacement is the increment of the position of the target relative to the current position of motor.				
	1	Absolute position instruction	Absolute displacement is the increment of the position of the target relative to the origin of motor				

P07-06	Parameter name	Setting method	Effective time	Default	Range	Category	Unit
	Waiting time unit	Shutdown setting	Effective immediately	0	0 to 1	-	-

Set the waiting unit of multi-segment position function. "waiting time" is the interval between the end of this instruction and the start of the next instruction.

Set value	Waiting time unit
0	ms
1	s

P07-09	Parameter name	Setting method	Effective time	Default	Range	Category	Unit
	The 1st segment displacement	Operation setting	Effective immediately	10000	-2147483647 to 2147483646	-	-

Set the 1st segment position displacement

P07-10	Parameter name	Setting method	Effective time	Default	Range	Category	Unit
	Maximum speed of the 1st segment displacement	Operation setting	Effective immediately	100	1 to 5000	-	rpm

Set the maximum speed of the 1st position displacement. Maximum running speed refers to the speed the motor that is not in the process of acceleration and deceleration. If P07-09 (1st position displacement) is set too small, the actual speed of motor would be less than P07-10.

P07-11	Parameter name	Setting method	Effective time	Default	Range	Category	Unit
	Acceleration and deceleration time of the 1st segment displacement	Operation setting	Effective immediately	100	1 to 65535	-	ms

Used to set the time when the motor in the multi-segment position is uniformly accelerated from 0rpm to the P07-10 (maximum speed of the 1st segment displacement) in the multi-segment position.

P07-12	Parameter name	Setting method	Effective time	Default	Range	Category	Unit
	Waiting time after completion of the 1st segment displacement	Operation setting	Effective immediately	100	1 to 65535	-	Set by P07-06

Used to set the waiting time before running the next segment displacement after the multi-segment position of the 1st displacement is completed

P07-13	Parameter name	Setting method	Effective time	Default	Range	Category	Unit
	The 2nd segment displacement	Operation setting	Effective immediately	10000	-2147483647 to 2147483646	-	-

P07-14	Parameter name	Setting method	Effective time	Default	Range	Category	Unit
	Maximum speed of the 2nd segment displacement	Operation setting	Effective immediately	100	1 to 5000	-	rpm

P07-15	Parameter name	Setting method	Effective time	Default	Range	Category	Unit
	Acceleration and deceleration time of the 2nd segment displacement	Operation setting	Effective immediately	100	1 to 65535	-	ms

	Parameter name	Setting method	Effective time	Default	Range	Category	Unit
P07-16	Waiting time after completion of the 2nd segment displacement	Operation setting	Effective immediately	100	1 to 65535	-	Set by P07-06

	Parameter name	Setting method	Effective time	Default	Range	Category	Unit
P07-17	The 3rd segment displacement	Operation setting	Effective immediately	10000	-2147483647 to 2147483646	-	-

	Parameter name	Setting method	Effective time	Default	Range	Category	Unit
P07-18	Maximum speed of the 3rd segment displacement	Operation setting	Effective immediately	100	1 to 5000	-	rpm

	Parameter name	Setting method	Effective time	Default	Range	Category	Unit
P07-19	Acceleration and deceleration time of the 3rd segment displacement	Operation setting	Effective immediately	100	1 to 65535	-	ms

	Parameter name	Setting method	Effective time	Default	Range	Category	Unit
P07-20	Waiting time after completion of the 3rd segment displacement	Operation setting	Effective immediately	100	1 to 65535	-	Set by P07-06

	Parameter name	Setting method	Effective time	Default	Range	Category	Unit
P07-21	The 4th segment displacement	Operation setting	Effective immediately	10000	-2147483647 to 2147483646	-	-

	Parameter name	Setting method	Effective time	Default	Range	Category	Unit
P07-22	Maximum speed of the 4th segment displacement	Operation setting	Effective immediately	100	1 to 5000	-	rpm

	Parameter name	Setting method	Effective time	Default	Range	Category	Unit
P07-23	Acceleration and deceleration time of the 4th segment displacement	Operation setting	Effective immediately	100	1 to 65535	-	ms

	Parameter name	Setting method	Effective time	Default	Range	Category	Unit
P07-24	Waiting time after completion of the 4th segment displacement	Operation setting	Effective immediately	100	1 to 65535	-	Set by P07-06

	Parameter name	Setting method	Effective time	Default	Range	Category	Unit
P07-25	The 5th segment displacement	Operation setting	Effective immediately	10000	-2147483647 to 2147483646	-	-

P07-26	Parameter name	Setting method	Effective time	Default	Range	Category	Unit
	Maximum speed of the 5th segment displacement	Operation setting	Effective immediately	100	1 to 5000	-	rpm

P07-27	Parameter name	Setting method	Effective time	Default	Range	Category	Unit
	Acceleration and deceleration time of the 5th segment displacement	Operation setting	Effective immediately	100	1 to 65535	-	ms

P07-28	Parameter name	Setting method	Effective time	Default	Range	Category	Unit
	Waiting time after completion of the 5th segment displacement	Operation setting	Effective immediately	100	1 to 65535	-	Set by P07-06

P07-29	Parameter name	Setting method	Effective time	Default	Range	Category	Unit
	The 6th segment displacement	Operation setting	Effective immediately	10000	-2147483647 to 2147483646	-	-

P07-30	Parameter name	Setting method	Effective time	Default	Range	Category	Unit
	Maximum speed of the 6th segment displacement	Operation setting	Effective immediately	100	1 to 5000	-	rpm

P07-31	Parameter name	Setting method	Effective time	Default	Range	Category	Unit
	Acceleration and deceleration time of the 6th segment displacement	Operation setting	Effective immediately	100	1 to 65535	-	ms

P07-32	Parameter name	Setting method	Effective time	Default	Range	Category	Unit
	Waiting time after completion of the 6th segment displacement	Operation setting	Effective immediately	100	1 to 65535	-	Set by P07-06

P07-33	Parameter name	Setting method	Effective time	Default	Range	Category	Unit
	The 7th segment displacement	Operation setting	Effective immediately	10000	-2147483647 to 2147483646	-	-

P07-34	Parameter name	Setting method	Effective time	Default	Range	Category	Unit
	Maximum speed of the 7th segment displacement	Operation setting	Effective immediately	100	1 to 5000	-	rpm

P07-35	Parameter name	Setting method	Effective time	Default	Range	Category	Unit
	Acceleration and deceleration time of the 7th segment displacement	Operation setting	Effective immediately	100	1 to 65535	-	ms

	Parameter name	Setting method	Effective time	Default	Range	Category	Unit
P07-36	Waiting time after completion of the 7th segment displacement	Operation setting	Effective immediately	100	1 to 65535	-	Set by P07-06

	Parameter name	Setting method	Effective time	Default	Range	Category	Unit
P07-37	The 8th segment displacement	Operation setting	Effective immediately	10000	-2147483647 to 2147483646	-	-

	Parameter name	Setting method	Effective time	Default	Range	Category	Unit
P07-38	Maximum speed of the 8th segment displacement	Operation setting	Effective immediately	100	1 to 5000	-	rpm

	Parameter name	Setting method	Effective time	Default	Range	Category	Unit
P07-39	Acceleration and deceleration time of the 8th segment displacement	Operation setting	Effective immediately	100	1 to 65535	-	ms

	Parameter name	Setting method	Effective time	Default	Range	Category	Unit
P07-40	Waiting time after completion of the 8th segment displacement	Operation setting	Effective immediately	100	1 to 65535	-	Set by P07-06

	Parameter name	Setting method	Effective time	Default	Range	Category	Unit
P07-41	The 9th segment displacement	Operation setting	Effective immediately	10000	-2147483647 to 2147483646	-	-

	Parameter name	Setting method	Effective time	Default	Range	Category	Unit
P07-42	Maximum speed of the 9th segment displacement	Operation setting	Effective immediately	100	1 to 5000	-	rpm

	Parameter name	Setting method	Effective time	Default	Range	Category	Unit
P07-43	Acceleration and deceleration time of the 9th segment displacement	Operation setting	Effective immediately	100	1 to 65535	-	ms

	Parameter name	Setting method	Effective time	Default	Range	Category	Unit
P07-44	Waiting time after completion of the 9th segment displacement	Operation setting	Effective immediately	100	1 to 65535	-	Set by P07-06

	Parameter name	Setting method	Effective time	Default	Range	Category	Unit
P07-45	The 10th segment displacement	Operation setting	Effective immediately	10000	-2147483647 to 2147483646	-	-

P07-46	Parameter name	Setting method	Effective time	Default	Range	Category	Unit
	Maximum speed of the 10th segment displacement	Operation setting	Effective immediately	100	1 to 5000	-	rpm

P07-47	Parameter name	Setting method	Effective time	Default	Range	Category	Unit
	Acceleration and deceleration time of the 10th segment displacement	Operation setting	Effective immediately	100	1 to 65535	-	ms

P07-48	Parameter name	Setting method	Effective time	Default	Range	Category	Unit
	Waiting time after completion of the 10th segment displacement	Operation setting	Effective immediately	100	1 to 65535	-	Set by P07-06

P07-49	Parameter name	Setting method	Effective time	Default	Range	Category	Unit
	The 11th segment displacement	Operation setting	Effective immediately	10000	-2147483647 to 2147483646	-	-

P07-50	Parameter name	Setting method	Effective time	Default	Range	Category	Unit
	Maximum speed of the 11th segment displacement	Operation setting	Effective immediately	100	1 to 5000	-	rpm

P07-51	Parameter name	Setting method	Effective time	Default	Range	Category	Unit
	Acceleration and deceleration time of the 11th segment displacement	Operation setting	Effective immediately	100	1 to 65535	-	ms

P07-52	Parameter name	Setting method	Effective time	Default	Range	Category	Unit
	Waiting time after completion of the 11th segment displacement	Operation setting	Effective immediately	100	1 to 65535	-	Set by P07-06

P07-53	Parameter name	Setting method	Effective time	Default	Range	Category	Unit
	The 12th segment displacement	Operation setting	Effective immediately	10000	-2147483647 to 2147483646	-	-

P07-54	Parameter name	Setting method	Effective time	Default	Range	Category	Unit
	Maximum speed of the 12th segment displacement	Operation setting	Effective immediately	100	1 to 5000	-	rpm

P07-55	Parameter name	Setting method	Effective time	Default	Range	Category	Unit
	Acceleration and deceleration time of the 12th segment displacement	Operation setting	Effective immediately	100	1 to 65535	-	ms

	Parameter name	Setting method	Effective time	Default	Range	Category	Unit
P07-56	Waiting time after completion of the 12th segment displacement	Operation setting	Effective immediately	100	1 to 65535	-	Set by P07-06

	Parameter name	Setting method	Effective time	Default	Range	Category	Unit
P07-57	The 13th segment displacement	Operation setting	Effective immediately	10000	-2147483647 to 2147483646	-	-

	Parameter name	Setting method	Effective time	Default	Range	Category	Unit
P07-58	Maximum speed of the 13th segment displacement	Operation setting	Effective immediately	100	1 to 5000	-	rpm

	Parameter name	Setting method	Effective time	Default	Range	Category	Unit
P07-59	Acceleration and deceleration time of the 13th segment displacement	Operation setting	Effective immediately	100	1 to 65535	-	ms

	Parameter name	Setting method	Effective time	Default	Range	Category	Unit
P07-60	Waiting time after completion of the 13th segment displacement	Operation setting	Effective immediately	100	1 to 65535	-	Set by P07-06

	Parameter name	Setting method	Effective time	Default	Range	Category	Unit
P07-61	The 14th segment displacement	Operation setting	Effective immediately	10000	-2147483647 to 2147483646	-	-

	Parameter name	Setting method	Effective time	Default	Range	Category	Unit
P07-62	Maximum speed of the 14th segment displacement	Operation setting	Effective immediately	100	1 to 5000	-	rpm

	Parameter name	Setting method	Effective time	Default	Range	Category	Unit
P07-63	Acceleration and deceleration time of the 14th segment displacement	Operation setting	Effective immediately	100	1 to 65535	-	ms

	Parameter name	Setting method	Effective time	Default	Range	Category	Unit
P07-64	Waiting time after completion of the 14th segment displacement	Operation setting	Effective immediately	100	1 to 65535	-	Set by P07-06

	Parameter name	Setting method	Effective time	Default	Range	Category	Unit
P07-65	The 15th segment displacement	Operation setting	Effective immediately	10000	-2147483647 to 2147483646	-	-

P07-66	Parameter name	Setting method	Effective time	Default	Range	Category	Unit
	Maximum speed of the 15th segment displacement	Operation setting	Effective immediately	100	1 to 5000	-	rpm

P07-67	Parameter name	Setting method	Effective time	Default	Range	Category	Unit
	Acceleration and deceleration time of the 15th segment displacement	Operation setting	Effective immediately	100	1 to 65535	-	ms

P07-68	Parameter name	Setting method	Effective time	Default	Range	Category	Unit
	Waiting time after completion of the 15th segment displacement	Operation setting	Effective immediately	100	1 to 65535	-	Set by P07-06

P07-69	Parameter name	Setting method	Effective time	Default	Range	Category	Unit
	The 16th segment displacement	Operation setting	Effective immediately	10000	-2147483647 to 2147483646	-	-

P07-70	Parameter name	Setting method	Effective time	Default	Range	Category	Unit
	Maximum speed of the 16th segment displacement	Operation setting	Effective immediately	100	1 to 5000	-	rpm

P07-71	Parameter name	Setting method	Effective time	Default	Range	Category	Unit
	Acceleration and deceleration time of the 16th segment displacement	Operation setting	Effective immediately	100	1 to 65535	-	ms

P07-72	Parameter name	Setting method	Effective time	Default	Range	Category	Unit
	Waiting time after completion of the 16th segment displacement	Operation setting	Effective immediately	100	1 to 65535	-	Set by P07-06

Group P10 Accessibility

P10-01	Parameter name	Setting method	Effective time	Default	Range	Category	Unit
	JOG speed	Operation setting	Effective immediately	100	0 to 3000	Accessibility	ms

Used to set JOG speed

P10-02	Parameter name	Setting method	Effective time	Default	Range	Category	Unit
	Factory reset	Shutdown setting	Effective immediately	0	0 to 65535	Accessibility	-

Write 1 to factory reset

Set value	Function
0	Invalid
1	Factory reset
Others	Reserved

P10-03	Parameter name	Setting method	Effective time	Default	Range	Category	Unit
	Fault clearing	Operation setting	Effective immediately	0	0 to 1	Accessibility	-

Fault reset operation selection

Set value	Function	Remarks
0	No operation	-
1	Fault clearing	For clearable faults, after the cause of fault is removed, and write 1 to the function code, the drive will stop the fault display and enter the Rdy (or RUN) state again.

Note: If the servo S-ON is valid, when the fault is removed and cleared, the servo will directly enter “Run” state. When performing fault clearing actions, please be sure to stop sending control instructions such as pulses to ensure personal safety.

P10-04	Parameter name	Setting method	Effective time	Default	Range	Category	Unit
	Motor overload protection time factor	Operation setting	Effective immediately	100	1 to 800	Accessibility	%

Set the time for code A-82 (Motor overload warning) and Er.34 (Motor overload protection fault) through this function code.

According to the heating condition of the motor, modifying this value could make the overload protection time fluctuate up and down the reference value. 50 corresponds to 50%, that is, the time is reduced by half; 300 corresponds to 300%, that is, the time is extended to 3 times.

P10-05	Parameter name	Setting method	Effective time	Default	Range	Category	Unit
	Motor model	Operation setting	Power-on again	0	0 to 65535	Accessibility	-

This function code displays the motor code of the motor currently recognized by the servo drive (including the last successful recognition).

Note: It is necessary to connect the motor first, and then power on the drive. Otherwise, it will report “Er.27” (encoder disconnection fault) .

P10-06	Parameter name	Setting method	Effective time	Default	Range	Category	Unit
	Multi-turn absolute encoder reset	Shutdown setting	Effective immediately	0	0 to 1	Accessibility	-

Used to clear the rotation number of multi-turn absolute encoder (U0-55), current position (U0-56) or clear the encoder fault alarms

Set value	Function
0	No operation;
1	Clear multi-turn data, encoder current position and encoder fault alarms

Note: After reset (P10-06 is set to 1), the absolute position of the encoder will change suddenly, and the mechanical origin return operation is required.

P10-07	Parameter name	Setting method	Effective time	Default	Range	Category	Unit
	Set machine code manually	Operation setting	Power-on again	0	0 to 1	Accessibility	-

This function code modifies the motor code of the servo drive. When set to 0, the motor code is read from the motor side; when set to 1, the motor code is read from the P10-5 motor model.

Note: VD2L manual setting machine code is inconsistent with other VD2 series drives: Used to modify the Motor Code of the servo drive.

0: Automatic reading of motor code
 1: Not read the motor code, use the motor code set by [P10-5]

Note: Do not modify it at will, otherwise it may cause motor damage.

	Parameter name	Setting method	Effective time	Default	Range	Category	Unit
P10-08	Multi-turn absolute encoder origin offset compensation	Operation setting	Effective immediately	0	-2147483647 to 2147483646	Accessibility	-

P10-08 multi-turn absolute encoder origin offset compensation is used in conjunction with U0-56 multi-turn absolute encoder current position. When P10-6 is set to 1, the value of U0-56 is updated to P10-8.

	Parameter name	Setting method	Effective time	Default	Set range	Application category	Unit
P10-11	Enable Function of Motor Stall and Overtemperature Protection	Operation setting	Power on again	0	0 to 1	Auxiliary function	-

This function code displays the motor code of the motor currently recognized by the servo drive (including the last successful recognition).

Set value	Function
0	When the motor is stalling, the actual rpm is less than 10. The torque instruction exceeds the rated torque. The continuous time is reaching the motor overheating protection time in the corresponding torque, which will report ER.45 fault and shutdown immediately.
1	When the motor is stalling, the torque is becoming the 70% of the rated. (Shield drive stalling over-temperature protection function, which will cause)

Group P12 Communication parameters

P12-01	Parameter name	Setting method	Effective time	Default	Range	Category	Unit
	Servo address	Operation setting	Effective immediately	1	1 to 247	Communication parameter	-

Set the Modbus communication address of servo drive

P12-02	Parameter name	Setting method	Effective time	Default	Range	Category	Unit
	Baud rate	Operation setting	Effective immediately	2	0 to 6	Communication parameter	-

Set the communication rate between servo drive and Modbus software.

Set value	Baud rate setting	Set value	Baud rate setting
0	2400 bps	4	38400 bps
1	4800 bps	5	57600 bps
2	9600 bps	6	115200bps
3	19200 bps		

The communication rate of the servo drive must be consistent with that of the ModBus software, otherwise it could not communicate.

P12-03	Parameter name	Setting method	Effective time	Default	Range	Category	Unit
	Serial data format	Operation setting	Effective immediately	0	0 to 3	Communication parameter	-

Used to set the data verification mode when the servo drive communicates with ModBus.

Set value	Data format
0	1 stop bit, no parity
1	1 stop bit, odd parity
2	1 stop bit, even parity
3	2 stop bits, no parity

The data format of servo drive must be consistent with that of the ModBus software, otherwise it could not communicate.

P12-04	Parameter name	Setting method	Effective time	Default	Range	Category	Unit
	Write Modbus communication data to EEPROM	Operation setting	Effective immediately	0	0 to 1	Communication parameter	-

Whether the function code written by the communication method is saved to EEPROM

Set value	Whether the function code written by the communication method is saved to EEPROM
0	Do not write to EEPROM, and do not save data after power failure;
1	Write to EEPROM, and save data after power failure;

Note: If you need to change the function code value frequently, it is recommended to set the function code to 0, otherwise the EEPROM would be damaged due to frequent erase of EEPROM. "Er.02" (Parameter Storage Error) will occur on the servo drive.

P12-05	Parameter name	Setting method	Effective time	Default	Range	Category	Unit
☆	RS422/RS485 function selection	Operation setting	Effective immediately	0	0 to 1	Communication parameter	-

Used to set the communication method of VD2F servo drive (The CN3 and CN4 of VD2F are time division multiplexing communication ports, and support RS422 and RS485 time division multiplexing).

Set value	Communication method
0	RS422 communication
1	RS485 communication

Note: "☆" indicates that only VD2F servo drive support this function code. The VD2-0XXSA1G model does not have this function code.

Parameter name	Setting method	Effective time	Default	Range	Category	Unit						
P12-06	Modbus 32-bit variable high and low byte order	Operation setting	Effective immediately	0	0 to 1	Communication parameter	-					
Used to set the data communication format when the servo driver communicates with ModBus.												
<table border="1"> <thead> <tr> <th>Set value</th> <th>Data definition</th> </tr> </thead> <tbody> <tr> <td>0</td> <td>In big-endian, the low address stores high 16-bit data, and the high address stores low 16-bit data.</td> </tr> <tr> <td>1</td> <td>In small-endian, the low address stores the low 16-bit data and the high address stores the high 16-bit data.</td> </tr> </tbody> </table>							Set value	Data definition	0	In big-endian, the low address stores high 16-bit data, and the high address stores low 16-bit data.	1	In small-endian, the low address stores the low 16-bit data and the high address stores the high 16-bit data.
Set value	Data definition											
0	In big-endian, the low address stores high 16-bit data, and the high address stores low 16-bit data.											
1	In small-endian, the low address stores the low 16-bit data and the high address stores the high 16-bit data.											
The data format of the servo drive must be consistent with that of the ModBus software; otherwise, communication will fail.												

Group P13 Communication input and output terminal

Parameter name	Setting method	Effective time	Default	Range	Category	Unit						
P13-01	Virtual VDI_1 input value	Operation setting	Effective immediately	0	0 to 1	DI/DO	-					
When P06-04 is set to 1, DI_1 channel logic is controlled by this function code.												
<table border="1"> <thead> <tr> <th>Set value</th> <th>VDI_1 input level</th> </tr> </thead> <tbody> <tr> <td>0</td> <td>High level</td> </tr> <tr> <td>1</td> <td>Low level</td> </tr> </tbody> </table>							Set value	VDI_1 input level	0	High level	1	Low level
Set value	VDI_1 input level											
0	High level											
1	Low level											

Parameter name	Setting method	Effective time	Default	Range	Category	Unit	
P13-02	Virtual VDI_2 input value	Operation setting	Effective immediately	0	0 to 1	DI/DO	-
When P06-07 is set to 1, DI_2 channel logic is controlled by this function code.							

Parameter name	Setting method	Effective time	Default	Range	Category	Unit	
P13-03	Virtual VDI_3 input value	Operation setting	Effective immediately	0	0 to 1	DI/DO	-
When P06-10 is set to 1, DI_3 channel logic is controlled by this function code.							

Parameter name	Setting method	Effective time	Default	Range	Category	Unit	
P13-04	Virtual VDI_2 input value	Operation setting	Effective immediately	0	0 to 1	DI/DO	-
When P06-13 is set to 1, DI_4 channel logic is controlled by this function code.							

Parameter name	Setting method	Effective time	Default	Range	Category	Unit	
P13-05	Virtual VDI_5 input value	Operation setting	Effective immediately	0	0 to 1	DI/DO	-
When P06-16 is set to 1, DI_5 channel logic is controlled by this function code.							

Parameter name	Setting method	Effective time	Default	Range	Category	Unit	
P13-06 ☆	Virtual VDI_6 input value	Operation setting	Effective immediately	0	0 to 1	DI/DO	-
When P06-19 is set to 1, DI_6 channel logic is controlled by this function code.							

Parameter name	Setting method	Effective time	Default	Range	Category	Unit	
P13-07 ☆	Virtual VDI_7 input value	Operation setting	Effective immediately	0	0 to 1	DI/DO	-
When P06-22 is set to 1, DI_7 channel logic is controlled by this function code.							

P13-08	Parameter name	Setting method	Effective time	Default	Range	Category	Unit
☆	Virtual VDI_8 input value	Operation setting	Effective immediately	0	0 to 1	DI/DO	-
When P06-25 is set to 1, DI_8 channel logic is controlled by this function code.							

P13-11	Parameter name	Setting method	Effective time	Default	Range	Category	Unit
	Virtual VDO_1 input value	Operation setting	Effective immediately	0	0 to 1	DI/DO	-
Used to set the input level logic when the DO function selected by VDO_1 is valid							
		Set value	VDo_1 input level				
		0	High level				
		1	Low level				

	Parameter name	Setting method	Effective time	Default	Range	Category	Unit
P13-12	Virtual VDO_2 input value	Operation setting	Effective immediately	0	0 to 1	DI/DO	-
P13-13	Virtual VDO_3 input value	Operation setting	Effective immediately	0	0 to 1	DI/DO	-
P13-14	Virtual VDO_4 input value	Operation setting	Effective immediately	0	0 to 1	DI/DO	-

“☆” indicates that the VD2F servo drive does not support this function code.

Group U0 Universal monitoring

U0-01	Monitoring name	Range	Category	Panel display	Unit	Data type												
	Servo status	1 to 4	Universal	Decimal	-	16-bit												
Display the status of servo drive.																		
<table border="1"> <thead> <tr> <th>Display value</th> <th>Status</th> <th>Display value</th> <th>Status</th> </tr> </thead> <tbody> <tr> <td>1</td> <td>Initialization</td> <td>3</td> <td>Run</td> </tr> <tr> <td>2</td> <td>Rdy and JOG</td> <td>4</td> <td>Fault</td> </tr> </tbody> </table>							Display value	Status	Display value	Status	1	Initialization	3	Run	2	Rdy and JOG	4	Fault
Display value	Status	Display value	Status															
1	Initialization	3	Run															
2	Rdy and JOG	4	Fault															

U0-02	Monitoring name	Range	Category	Panel display	Unit	Data type				
	Servo motor speed	-5000 to 5000	Universal	Decimal	rpm	16-bit				
Display the actual speed of servo drive. The accuracy is 1 rpm. The display of servo drive panel is as below.										
<table border="1"> <thead> <tr> <th>500 rpm display</th> <th>-500 rpm display</th> </tr> </thead> <tbody> <tr> <td></td> <td></td> </tr> </tbody> </table>							500 rpm display	-500 rpm display		
500 rpm display	-500 rpm display									

U0-03	Monitoring name	Range	Category	Panel display	Unit	Data type				
	Input speed instruction	-5000 to 5000	Universal	Decimal	rpm	16-bit				
Display input speed instruction. The accuracy is 1 rpm. The display of servo drive panel is as below.										
<table border="1"> <thead> <tr> <th>3000 rpm display</th> <th>-3000 rpm display</th> </tr> </thead> <tbody> <tr> <td></td> <td></td> </tr> </tbody> </table>							3000 rpm display	-3000 rpm display		
3000 rpm display	-3000 rpm display									

U0-04	Monitoring name	Range	Category	Panel display	Unit	Data type				
	Corresponding speed of position instruction	-5000 to 5000	Universal	Decimal	rpm	16-bit				
Display the current speed instruction value of servo drive in position mode. The accuracy is 1 rpm. The display of servo drive panel is as below.										
<table border="1"> <thead> <tr> <th>3000 rpm display</th> <th>-3000 rpm display</th> </tr> </thead> <tbody> <tr> <td></td> <td></td> </tr> </tbody> </table>							3000 rpm display	-3000 rpm display		
3000 rpm display	-3000 rpm display									

U0-05	Monitoring name	Range	Category	Panel display	Unit	Data type
	Pulse deviation	-2^{31} to 2^{31}	Universal	Decimal	Equivalent pulse deviation	32-bit

Display pulse deviation. If U0-05 is set to 32768, the display of servo drive panel is as below.

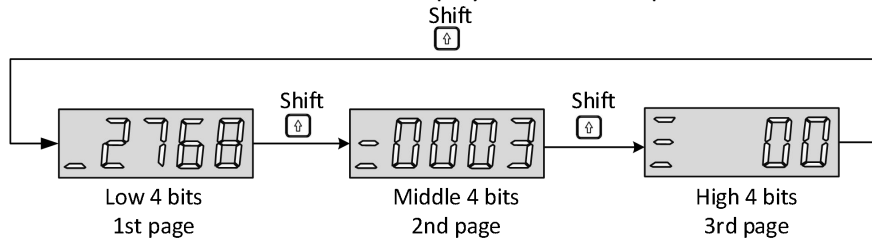

U0-08	Monitoring name	Range	Category	Panel display	Unit	Data type
	Input instruction pulse frequency	-	Universal	Decimal	KHz	16-bit

Display the input instruction pulse frequency of servo drive.

U0-09	Monitoring name	Range	Category	Panel display	Unit	Data type
	Input instruction pulse number	-2^{31} to 2^{31}	Universal	Decimal	Equivalent pulse deviation	32-bit

Display instruction pulse number that input the servo drive. If U0-09 is set to -2147483646, the display of servo drive panel is as below.

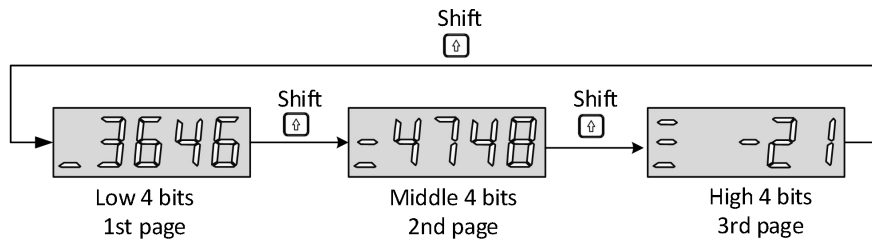

U0-12	Monitoring name	Range	Category	Panel display	Unit	Data type
	Real-time torque value	-3000 to 3000	Universal	Decimal	0.1%	16-bit

U0-13	Monitoring name	Range	Category	Panel display	Unit	Data type
	Encoder cumulative position (Lower 32 bits)	-2^{31} to 2^{31}	Universal	Decimal	Encoder unit	32-bit

U0-15	Monitoring name	Range	Category	Panel display	Unit	Data type
	Encoder cumulative position (High 32 bits)	-2^{31} to 2^{31}	Universal	Decimal	Encoder unit	32-bit

Display the cumulative data of encoder position. It is used with U0-13 cooperatively.

U0-16	Monitoring name	Range	Category	Panel display	Unit	Data type
	Shutdown vibration frequency	0 to 2000	Universal	Decimal	0.1Hz	16-bit

Display the detected frequency during the deceleration to stop.

U0-17	Monitoring name	Range	Category	Panel display	Unit	Data type
	DI input signal status	00000000 to 11111111	Universal	Binary	Encoder unit	16-bit

Display the current level status of DI terminal. The upper part of the digital tube of servo drive panel is lit up to indicate a high level (denoted by "1"). The lower part is lit up to indicate a low level (denoted by "0").

Take the DI1 to DI7 terminals as the high level and DI8 as the low level as an example. The corresponding binary code is "01111111", and Wecon servo control device debugging software U0-17 displays the current binary value is 0b0111 1111. The panel of servo drive is displayed as below.

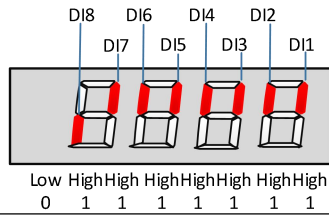

Monitoring name	Range	Category	Panel display	Unit	Data type
U0-19 DO output signal status	00000000 to 00001111	Universal	Binary	Encoder unit	16-bit

Display the current level status of 4 DO terminals. The upper part of the digital tube of servo drive panel is lit up to indicate a high level (denoted by "1"). The lower part is lit up to indicate a low level (denoted by "0"). Take the DO1, DO2 and DO3 terminals as the high level and DO2 as the low level as an example. The corresponding binary code is "1101", and Wecon servo upper computer debugging software U0-17 displays the current binary value is 0b0000 1101. The panel of servo drive is displayed as below.

DO4 DO2
DO3 DO1

high high low high
1 1 0 1

Monitoring name	Range	Category	Panel display	Unit	Data type
U0-20 Real-time load inertia ratio	0 to 1000000	Universal	Decimal	%	16-bit

Display the current load inertia ratio. If the load inertia ratio is 3 times (300%) , the panel of servo drive is displayed as below.

Monitoring name	Range	Category	Panel display	Unit	Data type
U0-21 AI1 input voltage value	-	Universal	Decimal	V	16-bit
Reserved☆					

Display the actual sampling voltage of analog channel 1.

10.00V display

-10.00V display

“☆” indicates that the VD2F and VD2L servo drive does not have this monitoring.

Monitoring name	Range	Category	Panel display	Unit	Data type
U0-22 AI2 input voltage value	-	Universal	Decimal	V	16-bit
Reserved☆					

“☆” indicates that the VD2F and VD2L servo drive does not have this monitoring.

Monitoring name	Range	Category	Panel display	Unit	Data type
U0-23 Vibration Frequency	-	Universal	Decimal	Hz	16-bit

Monitoring name	Range	Category	Panel display	Unit	Data type
U0-24 Vibration amplitude	-	Universal	Decimal	rpm	16-bit

Monitoring name	Range	Category	Panel display	Unit	Data type
U0-25 Forward torque limit value	0 to 300	Universal	Decimal	%	16-bit

Display the set value of P01-15 (forward torque limit) of servo drive. If U0-25 is 288%, the panel of servo drive is displayed as below.

U0-26	Monitoring name	Range	Category	Panel display	Unit	Data type
	Reverse torque limit value	0 to 300	Universal	Decimal	%	16-bit

Display the set value of P01-16 (reverse torque limit) of servo drive. If U0-26 is 300%, the panel of servo drive is displayed as below.

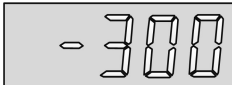

U0-27	Monitoring name	Range	Category	Panel display	Unit	Data type
	Forward speed limit value	0 to 5000	Universal	Decimal	rpm	16-bit

Display the set value of P01-12 (forward speed threshold) of servo drive. If P01-12 is set to 2000, the panel of servo drive is displayed as below.

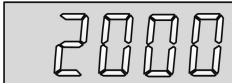

U0-28	Monitoring name	Range	Category	Panel display	Unit	Data type
	Reverse speed limit value	-5000 to 0	Universal	Decimal	rpm	16-bit

Display the set value of P01-13 (reverse speed threshold) of servo drive. If P01-13 is set to 3000, the panel of servo drive is displayed as below.

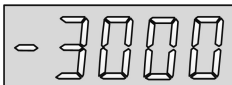

U0-29	Monitoring name	Range	Category	Panel display	Unit	Data type
	Mechanical angle	0 to 359	Universal	Decimal	°	16-bit

Display current mechanical angle of motor. 0 corresponds to a mechanical angle of 0 degree. If the mechanical angle is 270°, the panel of servo drive is displayed as below.

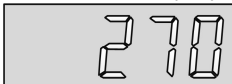

U0-30	Monitoring name	Range	Category	Panel display	Unit	Data type
	Electrical angle	0 to 359	Universal	Decimal	°	16-bit

Display current electrical angle of motor. The accuracy is 1°. When the motor rotates, the angle range is 360°. When the motor is 4 poles, every time the motor is rotated one turn, it undergoes a change process of 0° to 359° four times.

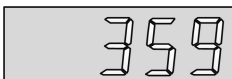

U0-31	Monitoring name	Range	Category	Panel display	Unit	Data type
	Bus voltage	-	Universal	Decimal	V	16-bit

Display the DC bus voltage of the main circuit input voltage of servo drive after rectification. If the bus voltage is 310.9, the panel of servo drive is displayed as below.

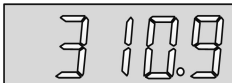

U0-32	Monitoring name	Range	Category	Panel display	Unit	Data type
	Radiator temperature	-	Universal	Decimal	°C	16-bit

U0-33	Monitoring name	Range	Category	Panel display	Unit	Data type
	Instantaneous output power	-	Universal	Decimal	W	16-bit

U0-34	Monitoring name	Range	Category	Panel display	Unit	Data type
	Average output power	-	Universal	Decimal	W	16-bit

U0-35	Monitoring name	Range	Category	Panel display	Unit	Data type
	Total operation time (hour)	-	Universal	Decimal	h	16-bit

U0-37	Monitoring name	Range	Category	Panel display	Unit	Data type
	Total operation time (minutes)	-	Universal	Decimal	min	16-bit

U0-38	Monitoring name	Range	Category	Panel display	Unit	Data type
	Total operation time (seconds)	-	Universal	Decimal	s	16-bit

U0-39	Monitoring name	Range	Category	Panel display	Unit	Data type
	Load torque percentage	-	Universal	Decimal	%	16-bit

Display current load torque percentage. If the current load torque percentage is 10.3%, the panel of servo drive is displayed as below.

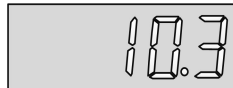

U0-40	Monitoring name	Range	Category	Panel display	Unit	Data type
	Current operation time (hour)	-	Universal	Decimal	h	16-bit

U0-42	Monitoring name	Range	Category	Panel display	Unit	Data type
	Current operation time (minutes)	-	Universal	Decimal	min	16-bit

U0-43	Monitoring name	Range	Category	Panel display	Unit	Data type
	Current operation time (seconds)	-	Universal	Decimal	s	16-bit

U0-44	Monitoring name	Range	Category	Panel display	Unit	Data type
	Instantaneous braking resistor power	-	Universal	Decimal	W	16-bit

U0-46	Monitoring name	Range	Category	Panel display	Unit	Data type
	Average braking resistor power	-	Universal	Decimal	W	16-bit

U0-48	Monitoring name	Range	Category	Panel display	Unit	Data type
	Power-on times	-	Universal	Decimal	Times	16-bit

U0-49	Monitoring value name	Range	Category	Panel display	Unit	Data type
	Internal counting of motor overload	--	Universal	Decimal	100	16 Bit

U0-50	Monitoring name	Range	Category	Panel display	Unit	Data type
	Motor cumulative number of turns (low 32 bits)	0 to $2^{32}-1$	Universal	Decimal	Cycle	32-bit

U0-51	Monitoring name	Range	Category	Panel display	Unit	Data type
	Motor cumulative number of turns (high 32 bits)	0 to $2^{32}-1$	Universal	Decimal	Cycle	32-bit

U0-53	Monitoring name	Range	Category	Panel display	Unit	Data type
	Motor model code	-	Universal	Hexadecimal	-	16-bit

Display current Motor model code. Take WD80M-07530S-A1F (A026) as an example, the panel of servo drive is displayed as below.

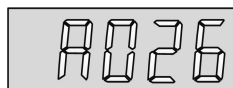

U0-54	Monitoring name	Range	Category	Panel display	Unit	Data type
-------	-----------------	-------	----------	---------------	------	-----------

	Absolute encoder position within 1 circle	0 to $2^{32}-1$	Universal	Decimal	Encoder unit	32-bit
Display the single turn position feedback value of absolute encoder						

U0-55	Monitoring name	Range	Category	Panel display	Unit	Data type
	Circle numbers of multi-turn absolute encoder	0 to 65535	Universal	Decimal	Encoder unit	32-bit
Display the circle number of multi-turn absolute encoder						

U0-56	Monitoring name	Range	Category	Panel display	Unit	Data type
	Multi-turn absolute encoder current position	-2^{31} to 2^{31}	Universal	Decimal	Instruction unit	32-bit
Display the absolute position of motor (instruction unit). It is only valid is multi-turn absolute encoder motor						

Group U1 Warning monitoring

U1-01	Monitoring name	Range	Category	Panel display	Unit	Data type
	Current fault code	-	Warning	-	-	16-bit
If there is fault in servo drive, it would display the corresponding fault. If not, the panel displays "---". Take the fault "encoder disconnection" as an example, the panel of servo drive is displayed as below.						
Servo drive has an fault "encoder disconnection"				Servo drive has no fault		

U1-02	Monitoring name	Range	Category	Panel display	Unit	Data type
	Current warning code	-	Warning	-	-	16-bit
If there is warning in servo drive, it would display the corresponding warning. If not, the panel displays "---". Take the warning "DI port configuration duplication" as an example, the panel is displayed as below.						
Servo drive has an warning "DI port configuration duplication"				Servo drive has no warning		

U1-03	Monitoring name	Range	Category	Panel display	Unit	Data type
	U phase current when faults occur	-	Warning	Decimal	A	16-bit

U1-04	Monitoring name	Range	Category	Panel display	Unit	Data type
	V phase current when faults occur	-	Warning	Decimal	A	16-bit

U1-05	Monitoring name	Range	Category	Panel display	Unit	Data type
	Bus voltage when faults occur	-	Warning	Decimal	V	16-bit

U1-06	Monitoring name	Range	Category	Panel display	Unit	Data type
	IGBT temperature when faults occur	-	Warning	Decimal	°C	16-bit

U1-07	Monitoring name	Range	Category	Panel display	Unit	Data type
	Torque component when faults occur	-	Warning	Decimal	%	16-bit

U1-08	Monitoring name	Range	Category	Panel display	Unit	Data type
	Excitation component when faults occur	-	Warning	Decimal	%	16-bit

U1-09	Monitoring name	Range	Category	Panel display	Unit	Data type
	Position deviation when faults occur	-	Warning	Decimal	Encoder unit	32-bit

U1-10	Monitoring name	Range	Category	Panel display	Unit	Data type
	The speed when faults occur	-	Warning	Decimal	rpm	16-bit
U1-11	Monitoring name	Range	Category	Panel display	Unit	Data type
	The time when faults occur	-	Warning	Decimal	s	16-bit
U1-12	Monitoring name	Range	Category	Panel display	Unit	Data type
	Number of faults in this operation	-	Warning	Decimal	-	16-bit
U1-13	Monitoring name	Range	Category	Panel display	Unit	Data type
	Number of warnings in this operation	-	Warning	Decimal	-	16-bit
U1-14	Monitoring name	Range	Category	Panel display	Unit	Data type
	Total number of historical faults	-	Warning	Decimal	-	16-bit
U1-15	Monitoring name	Range	Category	Panel display	Unit	Data type
	Total number of historical warnings	-	Warning	Decimal	-	16-bit
U1-16	Monitoring name	Range	Category	Panel display	Unit	Data type
	The 1st fault code of the most recent	-	Warning	-	-	16-bit
Display the 1st fault code of the most recent of servo drive						
U1-17	Monitoring name	Range	Category	Panel display	Unit	Data type
	The 2nd fault code of the most recent	-	Warning	-	-	16-bit
U1-18	Monitoring name	Range	Category	Panel display	Unit	Data type
	The 3rd fault code of the most recent	-	Warning	-	-	16-bit
U1-19	Monitoring name	Range	Category	Panel display	Unit	Data type
	The 4th fault code of the most recent	-	Warning	-	-	16-bit
U1-20	Monitoring name	Range	Category	Panel display	Unit	Data type
	The 5th fault code of the most recent	-	Warning	-	-	16-bit
U1-21	Monitoring name	Range	Category	Panel display	Unit	Data type
	The 1st warning code of the most recent	-	Warning	-	-	16-bit
Display the 1st warning code of the most recent of servo drive						
U1-22	Monitoring name	Range	Category	Panel display	Unit	Data type
	The 2nd warning code of the most recent	-	Warning	-	-	16-bit
U1-23	Monitoring name	Range	Category	Panel display	Unit	Data type
	The 3rd warning code of the most recent	-	Warning	-	-	16-bit
U1-24	Monitoring name	Range	Category	Panel display	Unit	Data type
	The 4th warning code of the most recent	-	Warning	-	-	16-bit
U1-25	Monitoring name	Range	Category	Panel display	Unit	Data type
	The 5th warning code of the most recent	-	Warning	-	-	16-bit

Group U2 Device monitoring

U2-01	Monitoring name	Range	Category	Panel display	Unit	Data type
	Product series	-	Device	Hexadecimal	-	16-bit

Display the product series code of servo drive.
The code name of VD2 A and VD2 B servo drivers is 0x4432, and the code name of VD2F servo drivers is 0x3246; The VD2L servo driver is codenamed 0x324C. The panel is shown below.

4432

3246

324C

U2-02	Monitoring name	Range	Category	Panel display	Unit	Data type
	Model	-	Device	Hexadecimal	-	16-bit

Display the servo drive model.

	U2-01 display	U2-02 display	Model
		0301	VD2-010SA1G
		0401	VD2-014SA1G
		0501	VD2-016SA1G
4432		0601	VD2-019SA1G
		0701	VD2-021SA1G
		0801	VD2-025SA1G
		0901	VD2-030SA1G
3246		0301	VD2F-010SA1P
		0401	VD2F-014SA1P

U2-03	Monitoring name	Range	Category	Panel display	Unit	Data type
	Model	-	Warning	Hexadecimal	-	16-bit

	U2-01 display	U2-02 display	U2-03 display	Model
	4432	0703	0301	VD2-021TA1G

U2-04	Monitoring name	Range	Category	Panel display	Unit	Data type
	Firmware version	-	Device	Decimal	-	16-bit

Display the firmware version. Display format: X.YY. For example, 1.13. The panel is displayed as below.

1.13

U2-05	Monitoring name	Range	Category	Panel display	Unit	Data type
	FPGA version	-	Device	Decimal	-	16-bit

Display the hardware version (FPGA)
Display format: X.YY. For example, 1.01. The panel is displayed as below.

1.01

U2-06	Monitoring name	Range	Category	Panel display	Unit	Data type
	Manufacture date (year)	-	Device	Decimal	Year	16-bit
Firmware date (year) *						

Display the year of manufacture of the VD2F drive firmware.

U2-07	Monitoring name	Range	Category	Panel display	Unit	Data type
	Manufacture date (month)	-	Device	Decimal	Month	16-bit
Firmware date (month) *						

Display the month of manufacture of the VD2F drive firmware.

U2-08	Monitoring name	Range	Category	Panel display	Unit	Data type
	Manufacture date (day)	-	Device	Decimal	Day	16-bit
Firmware date (day) *						

Displays the production date of the VD2F drive firmware.
For example, the firmware production day of VD2F-014SA1P_V1.01 is January 10, 2022, the panel is displayed as below.

U2-06	U2-07	U2-08
22	1	10

U2-09	Monitoring name	Range	Category	Panel display	Unit	Data type
	Device serial number 1	-	Warning	Decimal	-	16-bit

U2-10	Monitoring name	Range	Category	Panel display	Unit	Data type
	Device serial number 2	-	Warning	Decimal	-	16-bit

U2-11	Monitoring name	Range	Category	Panel display	Unit	Data type
	Device serial number 3	-	Warning	Decimal	-	16-bit

U2-12	Monitoring name	Range	Category	Panel display	Unit	Data type
	Device serial number 4	-	Warning	Decimal	-	16-bit

U2-13	Monitoring name	Range	Category	Panel display	Unit	Data type
	Device serial number 5	-	Warning	Decimal	-	16-bit

U2-14	Monitoring name	Range	Category	Panel display	Unit	Data type
	Device serial number 6	-	Warning	Decimal	-	16-bit

U2-15	Monitoring name	Range	Category	Panel display	Unit	Data type
	Device serial number 7	-	Warning	Decimal	-	16-bit

U2-16	Monitoring name	Range	Category	Panel display	Unit	Data type
	Device serial number 8	-	Warning	Decimal	-	16-bit

10. Malfunctions

10.1 Faults and warnings handling at startup

10.1.1 Position control mode

Boot process	Fault phenomenon	Reason	Confirmation method	
Power supply (L1, L2, L3) Turn on control supply (L1C, L2C)	① Digital tube does not light up	Control terminal is disconnected	<ul style="list-style-type: none"> ☞ Rewiring ☞ L1C and L2C power lines are led separately from the socket 	
	② Voltage indicator does not light up	Control the supply voltage failure	Measures the AC voltage between L1C & L2C.	
		Servo drive fault	Contact the agent or customer service	
	Panel display "Er.xx"	Refer to 10.2 Handling of faults and warnings during operation		
After removing the fault, the servo drive panel should display "rdy"				
Servo drive enable signal is valid (S-ON is ON)	The axis of servo motor is in a free running state	Servo enable signal is invalid	<ul style="list-style-type: none"> ☞ Check whether group P06 is set the servo enable signal (DI function 1: S-ON). If it is, check whether the corresponding DI terminal logic is valid. If it is invalid, please make it valid. Refer to Group P06 DI/DO configuration ☞ If group P06 parameters have set the servo enable signal, and the corresponding terminal logic is valid, but the panel still displays "rdy", check whether the DI terminal wiring is correct, please refer to 4 Wiring 	
		Control mode error	Check whether the parameter P00-01 is set correctly	
	Panel displays Er.xx	Refer to 10.2 Handling of faults and warnings during operation		
	After troubleshooting, the servo drive panel should display "run"			

Input position instruction	The motor does not rotate	U0-09 (input instruction pulse number) always displays 0	Not input position instruction ① Confirm whether DI terminal uses forward drive prohibited (DI function 3: POT) or reverse drive prohibited (DI function 4: NOT). ② Confirm whether DI terminal uses instruction pulse input prohibited (DI function 11: INH) ③ When P01-06=0(position instruction source), PLC or other pulse output device do not output pulse. Please use oscilloscope to check whether there is pulse input or check U0-08 (input instruction pulse frequency). Refer to 4 Wiring ④ When P01-06=1(position instruction source), please check whether the parameters of group P07 are set correctly. If yes, please confirm whether the DI function 20 (internal multi-segment position enable signal) and the corresponding DI terminal logic are set to be valid. Refer to Group P07 multi-segment position
			After troubleshooting, the servo motor should be able to rotate normally
The motor does not rotate smoothly at low speed	Unstable low speed	Unreasonable gain setting	Please adjust the gain.
	The motor shaft vibrates left and right	Load inertia ratio is too large	After the inertia recognition is complete, performs gain adjustment.
	After troubleshooting, the servo motor should be able to rotate normally		
Normal operation	Inaccurate positioning	There is a position deviation that does not meet production requirements	⚙️ Confirm the U0-09 value (input instruction pulse number) is consistent with the actual one sent by the host computer. If not, please check confirm whether the motor is blocked. ⚙️ Confirm whether the device is vibrating. If yes, adjust the gain. ⚙️ Confirm whether the coupling at the motor shaft is locked.

10.1.2 Speed control mode

Boot process	Fault phenomenon	Reason	Confirmation method
Power supply (L1, L2, L3) Turn on control supply (L1C, L2C)	① Digital tube does not light up ② Voltage indicator does not light up	Control terminal is disconnected	⚙️ Rewiring ⚙️ L1C and L2C power lines are led separately from the socket
		Control the supply voltage failure	Measures the AC voltage between L1C & L2C.

		Servo drive fault	Contact the agent or customer service
	Panel display "Er.xx"	Refer to 10.2 Handling of faults and warnings during operation	
After removing the fault, the servo drive panel should display "rdy"			
Servo drive enable signal is valid(S-ON is ON)	The axis of servo motor is in a free running state	Servo enable signal is invalid	<ul style="list-style-type: none"> ☞ Check whether group P06 is set the servo enable signal (DI function 1: S-ON). If it is, check whether the corresponding DI terminal logic is valid. If it is invalid, please make it valid. Refer to Group P06 DI/DO configuration ☞ If group P06 parameters have set the servo enable signal, and the corresponding terminal logic is valid, but the panel still displays "rdy", check whether the DI terminal wiring is correct, please refer to 4 Wiring
		Control mode error	Check whether the parameter P00-01 is set correctly
	Panel display Er.xx	Refer to 10.2 Handling of faults and warnings during operation	
	After troubleshooting, the servo drive panel should display "run"		
Input torque instruction	The motor does not rotate	U0-03 (input instruction pulse number) always displays 0	<ul style="list-style-type: none"> ☞ AI wiring error When selecting analog input signal, make sure that the connection of analog input terminal is correct. Refer to 4 Wiring. ☞ Not input speed instruction or speed instruction abnormal <ol style="list-style-type: none"> ① When selecting analog input signal, please confirm the AI parameters of group P05 is set correct, and then check the analog input voltage signal. It could be observed by oscilloscope or read by monitoring U0-21 and U0-22. ② When the internal speed instruction is given, please confirm P01-02 (internal speed instruction) is 0. ③ When using multi-segment speed function, please confirm the internal speed instruction parameters 0 to 7 of group P01 are right. ④ Please confirm whether the ZERO-speed clamp function is used for the DI terminal. (DI function 5: ZCLAMP)
			After troubleshooting, the servo motor should be able to rotate normally
The motor does not rotate smoothly at low speed	Unstable low speed	Unreasonable gain setting	Please adjust the gain.
	The motor shaft vibrates left and right	Load inertia ratio is too large	After the inertia recognition is complete, performs gain adjustment.

After troubleshooting, the servo motor should be able to rotate normally

Note: VD2F does not support monitoring U0-21 and U0-22.

10.1.3 Torque control mode

Boot process	Fault phenomenon	Reason	Confirmation method
Power supply (L1, L2, L3) Turn on control supply (L1C, L2C)	① Digital tube does not light up ② Voltage indicator does not light up	Control terminal is disconnected	<ul style="list-style-type: none"> ✎ Rewiring ✎ L1C and L2C power lines are led separately from the socket
		Control the supply voltage failure	Measures the AC voltage between L1C & L2C.
		Servo drive fault	Contact the agent or customer service
	Panel display "Er.xx"	Refer to 10.2 Handling of faults and warnings during operation	
After removing the fault, the servo drive panel should display "rdy"			
Servo drive enable signal is valid(S-ON is ON)	The axis of servo motor is in a free running state	Servo enable signal is invalid	<ul style="list-style-type: none"> ✎ Check whether group P06 is set the servo enable signal (DI function 1: S-ON). If it is, check whether the corresponding DI terminal logic is valid. If it is invalid, please make it valid. Refer to Group P06 DI/DO configuration ✎ If group P06 parameters have set the servo enable signal, and the corresponding terminal logic is valid, but the panel still displays "rdy", check whether the DI terminal wiring is correct, please refer to 4 Wiring
		Control mode error	Check whether the parameter P00-01 is set correctly
	Panel display Er.xx	Refer to 10.2 Handling of faults and warnings during operation	
	After troubleshooting, the servo drive panel should display "run"		
Input speed instruction	The motor does not rotate	U0-03 (input instruction pulse number) always displays 0	<ul style="list-style-type: none"> ✎ AI wiring error When selecting analog input signal, make sure that the connection of analog input terminal is correct. Refer to 4 Wiring. ✎ Not input torque instruction <ul style="list-style-type: none"> ① When selecting analog input signal, please confirm the AI parameters of group P05 is set correct, and then check the analog input voltage signal. It could be observed by oscilloscope or read by monitoring U0-21 and U0-22. ② When the internal speed instruction is given, please confirm P01-08 (torque instruction keyboard set value) is 0.
			After troubleshooting, the servo motor should be able to rotate normally

The motor does not rotate smoothly at low speed	Unstable low speed	Unreasonable gain setting	Please adjust the gain.
	The motor shaft vibrates left and right	Load inertia ratio is too large	After the inertia recognition is complete, performs gain adjustment.
	After troubleshooting, the servo motor should be able to rotate normally		

Note: VD2F and VD2L does not support monitoring U0-21 and U0-22.

10.2 Faults and warnings handling during operation

10.2.1 Overview

The faults and warnings of Wecon VD2 series servo drives are graded according to their severity, which can be divided into four grades: Category 1, Category 2, Category 3, Category 4. Severity level: Category 1 > Category 2 > Category 3 > Category 4, the specific classifications are as follows:

- Category 1: faults cannot be cleared;
- Category 2: faults are clearable;
- Category 3: faults are clearable;
- Category 4: warnings are clearable.

Among them, "clearable" means that the panel stops the fault display state by giving a "clear signal".

The specific operations are as follows:

- ① Set the function code P10-03=1 (fault clearing) or use DI function 02 (02-A-CLR, fault and warning clearing) and set it to logic valid, which can stop the fault display on the panel.
- ② The clearing method of category 2 and category 3 clearable faults: first turn off the servo enable signal (set S-ON to OFF), then set P10-03=1 or use DI function 02.
- ③ The clearing method of category 4 of clearable warnings: set P10-03=1 or use DI function 02.

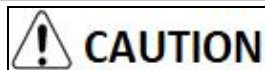

For some faults and warnings, you must change the settings to eliminate the causes before they can be cleared, but clearing does not mean that the changes take effect. For the changes that need to be re-powered to take effect, the power must be re-powered. For the changes that need to be stopped to take effect, the servo enable must be turned off. After the change takes effect, the servo drive can operate normally.

Associated function codes

Function Code	Name	Setting method	Effective time	Default value	Range	Definition	Unit
P10-03	Fault clearing	Operation setting	immediately Effective	0	0 to 1	0: No operation 1: For clearable faults, after the cause of fault is removed, and write 1 to the function code, the drive will stop the fault display and enter the Rdy (or RUN) state again.	-

						Note: If the servo S-ON is valid, when the fault is removed and cleared, the servo will directly enter the Run state. When performing fault clearing actions, be sure to stop sending control instructions such as pulses to ensure personal safety.
--	--	--	--	--	--	---

Associated function number:

Code	Name	Function name	Function
2	A-CLR	Fault and warning clearing	DI port logic is invalid, no reset faults and warnings DI port logic is valid, reset faults and warnings

VD2 series servo drives have a fault recording function, which could record the last 5 faults and the last 5 warning names and the status parameters of servo drive when the fault or warning occurs. After the fault or warning is cleared, the fault record will still save the fault and warning. The current fault code could be viewed through the monitoring parameter U1-01, and the current warning code could be viewed through U1-02. The monitoring U1-16 to U1-25 could display the last 5 fault codes and warning codes. Please refer to [Group U1 Warning monitoring](#).

10.2.2 Fault and warning code table

(1) The first category (category 1 for short) The fault could not be cleared

Category	Error name	Fault code	Content	Whether Clearable	Operation
Category 1	Parameter destruction	Er.01	Abnormal servo internal parameters	No	Stop immediately
Category 1	Parameter storage error	Er.02	Abnormal servo internal parameters	No	Stop immediately
Category 1	ADC reference source faults	Er.03	Abnormal ADC reference source	No	Stop immediately
Category 1	AD current sampling conversion error	Er.04	AD current sampling conversion error	No	Stop immediately
Category 1	Abnormal FPGA communication	Er.05	Abnormal FPGA communication	No	Stop immediately
Category 1	Wrong FPGA program version	Er.06	Wrong FPGA program version	No	Stop immediately
Category 1	Clock abnormal	Er.07	Clock abnormal	No	Stop immediately
Category 1	ADC conversion undone	Er.60	ADC conversion error	No	Stop immediately
Category 1	Internal software fault	Er.61	Abnormal servo internal software	No	Stop immediately
Category 1	Internal software fault	Er.62	Abnormal servo internal software	No	Stop immediately

Category 1	Internal software fault	Er.63	Abnormal servo internal software	No	Stop immediately
Category 1	Internal software fault	Er.64	Abnormal servo internal software	No	Stop immediately
Category 1	Internal software fault	Er.65	Abnormal servo internal software	No	Stop immediately
Category 1	Motor model error	Er.26	Motor model error	No	Stop immediately
Category 1	Encoder Z pulse lost	Er.28	Encoder Z pulse lost	No	Stop immediately
Category 1	Encoder UVW signal error	Er.30	Encoder UVW signal error	No	Stop immediately
Category 1	Exceeds motor maximum speed	Er.32	Exceeds motor maximum speed	No	Stop immediately
Category 1	Over current	Er.20	Servo drive hardware overcurrent	No	Stop immediately
Category 1	The brake resistor is turned on abnormally	Er.24	The brake resistor of servo drive is turned on abnormally	No	Stop immediately

(2) The 2nd category (category 2 for short) clearable faults

Category	Error name	Fault code	Content	Whether Clearable	Operation
Category 2	Main power supply overvoltage	Er.22	Main power supply overvoltage	Yes	Stop immediately
Category 2	Encoder disconnection	Er.27	The encoder cable is incorrectly connected	Yes	Stop immediately
Category 2	Power line disconnection	Er.31	The power cable is incorrectly connected	Yes	Stop immediately

(3) The 3rd Category (category 3 for short) clearable faults

Category	Error name	Fault code	Content	Whether clearable	Operation
Category 3	Main power supply under voltage	Er.21	Main power supply under voltage	Yes	Stop immediately
Category 3	Braking resistor is not connected	Er.23	Braking resistor is not connected	Yes	Stop immediately
Category 3	Braking resistor resistance is too large	Er.25	Braking resistor resistance is too large	Yes	Stop immediately
Category 3	Power module is over temperature	Er.33	Power module is over temperature	Yes	Stop immediately
Category 3	Motor overload protection	Er.34	Motor overload protection	Yes	Stop immediately
Category 3	Electronic gear ratio exceeds limit	Er.35	Electronic gear ratio exceeds limit	Yes	Stop immediately
Category 3	Position deviation is too large	Er.36	Position deviation is too large	Yes	Stop immediately

Category 3	Torque saturation abnormal	Er.37	Torque saturation abnormal	Yes	Stop immediately
Category 3	Main circuit electricity is lack of phase	Er.38	Main circuit electricity is lack of phase	Yes	Stop immediately
Category 3	Emergency stop	Er.39	Triggered the emergency stop signal	Yes	Stop immediately
Category 3	Encoder battery failure	Er.40	Encoder battery failure	Yes	Stop immediately
Category 3	Motor (encoder) over temperature	Er.41	Motor (encoder) over temperature	Yes	Stop immediately
Category 3	Encoder write faults	Er.42	The encoder fails to write data	Yes	Stop immediately

(4) The 4th category (category 4 for short) clearable warnings

Category	Error name	Fault code	Content	Whether Clearable	Operation
Category 4	Overspeed alarm	A-81	Motor exceeds the speed limit	Yes	Continue to run
Category 4	Overload	A-82	The motor was run continuously with a torque exceeding the rated value	Yes	Continue to run
Category 4	Braking resistor is over temperature or overloaded	A-83	Braking resistor is over temperature or overloaded	Yes	Continue to run
Category 4	Parameter modification that needs to be powered on again	A-84	Modify the parameter that needs to be powered on again	Yes	Continue to run
Category 4	Receive position pulse when servo is OFF	A-85	Servo drive receives position pulse when it is OFF	Yes	Continue to run
Category 4	Input pulse frequency is too high	A-86	Input pulse frequency is too high	Yes	Continue to run
Category 4	Main circuit momentary power off	A-88	Main circuit momentary power off	Yes	Continue to run
Category 4	DI port configuration is duplicate	A-89	DI port configuration is duplicate	Yes	Continue to run
Category 4	DO port configuration is duplicate	A-90	DO port configuration is duplicate	Yes	Continue to run
Category 4	Parameter modification is too frequent	A-91	Parameter modification is too frequent	Yes	Continue to run
Category 4	low encoder battery voltage Warning	A-92	The battery voltage of encoder is less than 3.1V	Yes	Continue to run
Category 4	Encoder read and write check abnormal and frequency is too high	A-93	Encoder read and write check abnormal and frequency is too high	Yes	Continue to run

10.3 Troubleshooting

Er.01 Parameter destruction

Fault

Servo drive panel display	Fault name
	Parameter destruction

Troubleshooting

Reason	Troubleshooting methods	Handling
EEPROM could not be read and written	Factory reset the parameter (P10-02=1) and power on again. If the servo drive still alarms after multiple operations, it is faulty.	Please contact the technician.

Er.02 Parameter storage error

Fault

Servo drive panel display	Fault name
	Parameter storage error

Troubleshooting

Reason	Troubleshooting methods	Handling
Firmware upgraded	Check whether the program has been upgraded.	Power on the servo drive again
Parameter read and write exceptions	After a parameter is changed, power it on again and check whether the parameter is saved	If the parameters are not saved after multiple power-on, contact technician.
Servo drive firmware faulty	Check if the servo drive monitoring quantity U2-04 (firmware version) is in the following range. VD2-0xxSA1G model: earlier than V1.14. VD2F-0xxSA1P model: earlier than V1.02	VD2-0xxSA1G model: Contact manufacturer to upgrade the firmware to V1.14 and above. VD2F-0xxSA1P model: Contact technician to upgrade the firmware to V1.02 and above.

Er.03 ADC reference source fault

Fault

Servo drive panel display	Fault name
	ADC reference source fault

Troubleshooting

Reason	Troubleshooting methods	Handling
The internal analog reference source of the drive is not accurate	Factory reset the parameter (P10-02=1) and power on again. If the servo drive still alarms after multiple operations, it is faulty.	If there is still alarm after multiple power-on, contact the technician.

Er.04 AD current sampling conversion error

Fault

Servo drive panel display	Fault name
	AD current sampling conversion error

Troubleshooting

Reason	Troubleshooting methods	Handling
Current sampling timeout	Factory reset the parameter (P10-02=1) and power on again. If the servo drive still alarms after multiple operations, it is faulty.	If there is still alarm after multiple power-on, contact the technician.
current sensor error		

Er.05 FPGA communication abnormal

Fault

Servo drive panel display	Fault name
	FPGA communication abnormal

Troubleshooting

Reason	Troubleshooting methods	Handling
FPGA communication abnormal	Factory reset the parameter (P10-02=1) and power on again. If the servo drive still alarms after multiple operations, it is faulty.	If there is still alarm after multiple power-on, contact the technician.

Er.06 Wrong FPGA program version

Fault

Servo drive panel display	Fault name
	Wrong FPGA program version

Troubleshooting

Reason	Troubleshooting methods	Handling
The FPGA program version does not match firmware version	Check whether the monitoring quantity of servo drive U2-04 (firmware version) and U2-05 (hardware version) conform to the following table	Contact technical to upgrade FPGA (hardware version)
Servo drive fault	Factory reset the parameter (P10-02=1) and power on again. If the servo drive still alarms after multiple operations, it is faulty.	If there is still alarm after multiple power-on, contact the technician.

Firmware version	Hardware version
1.00	1.00
1.10	1.01
1.11	1.01
1.12	1.01
1.13	1.01
1.14	1.01

Table 10-1 The firmware version and hardware version relationship of VD2-0SA1G servo drive

Er.07 Clock abnormal

Fault

Servo drive panel display	Fault name
	Clock abnormal

Troubleshooting

Reason	Troubleshooting methods	Handling
External interference	Check for strong magnetic fields nearby	Eliminate nearby strong magnetic interference
	Check whether there are sources of interference such as power supply inverter equipment nearby	Separate strong and weak power as much as possible, with good ground contact between motor and servo drive, and keep away from power cable wiring.
Servo drive fault	Factory reset the parameter (P10-02=1) and power on again. If the servo drive still alarms after multiple operations, it is faulty.	If there is still alarm after multiple power-on, contact the technician.

Er.20 Overcurrent

Fault

Servo drive panel display	Fault name
	Overcurrent

Troubleshooting

Reason	Troubleshooting methods	Handling
The UVW phase sequence of motor power cable is incorrect	Check whether the phase sequence of the motor power cable on the servo drive side and motor side corresponds to each other.	Connect correctly according to UVW on the drive side and UVW on the motor side
Motor power lines are short-circuited	Check whether power line UVW is short-circuited to PE	Replace motor power line
The motor power line wiring port is poorly contacted	Check whether the motor power line connection port is connected reliably	Tighten the fixing screws of the motor power line connection ports
Abnormal braking resistance	Internal brake resistance wiring error: check whether C, D are connected to the short cap and the contact is normal	Connect the short cap or short wire between C and D reliably
	External braking resistor wiring error: Check whether the external resistor is connected reliably between P+ and C.	External braking resistance is reliably strung between P+ and C

	Short-circuit of the built-in brake resistance: Check whether the built-in brake resistance is short-circuited.	Remove the shorting cap between C and D, and reliably string the external braking resistor of equal resistance between P+ and C. Contact technician to replace the internal braking resistor
	The resistance value of the external braking resistor is too small: Test the resistance value of the external braking resistor actually selected and compare it with the recommended braking resistor to confirm whether the resistance value of the actual resistor is too small	Choose a suitable external braking resistor
Encoder wiring error; loose plug	Check whether the cable port (CN1) of the encoder is properly connected	Tighten the fixing screws on the CN1 port
	Check whether the servo drive CN1 port jack is deformed	If the cable is deformed, replace the cable or its port
	Check whether both ends of the rectangular connector are reliably connected	Make sure that both ends of the rectangular connector are connected reliably; Replace it with an encoder cable with higher connection reliability.
Unreasonable parameter settings	Check whether P03-02 (Load rigidity Level) is set properly	Reduce the P03-02 (load stiffness level) setting value appropriately
	Check whether the gain parameters are set properly, resulting in overshoot	Adjust gain parameters reasonably
Frequent acceleration and deceleration	Check whether the acceleration and deceleration motion is frequent or the acceleration and deceleration time is too small	Appropriately extend the acceleration and deceleration time
Internal servo drive fault	Cross-verification. Use the normal motor, encoder cable to connect to the servo drive, only connect the encoder cable. If the servo drive still alarm, it is failure.	Contact technician for repair

Er.21 Main power supply undervoltage

Fault

Servo drive panel display	Fault name
	Main power supply undervoltage

Reason: DC bus voltage is lower than the fault value.

- 220V drive: DC bus voltage normal value is 310V; DC bus voltage fault value is 200V.
- 380V drive: DC bus voltage normal value is 540V; DC bus voltage fault value is 420V.

Troubleshooting

Reason	Troubleshooting methods	Handling
Power-off when VD2A drive is enabled	Check whether the servo drive is Power off when logic is valid. and the S-ON function is enabled in the P06 "DIDO Function configuration parameter".	It belongs to servo internal software logic. When the indicator light on the servo drive panel goes out automatically, the alarm will be removed automatically.
The power supply is unstable or OFF.	Check whether the drive input power specifications meet the following specifications: 220V drive: Valid value is 198V to 242V. 380V drive: Valid value is 342V to 440V.	Use after the power supply is stable; Increase power supply capacity
The voltage drops during operation of the servo drive	Check whether the servo drive shares the same power supply with other high loads	Turn off other loads from the same main circuit power supply. Separate power supply for servo drives
Missing phase (3-phase power supply operating on single-phase power)	Check if the main circuit wiring is correct VD2A: single-phase 220V input connected to L1, L3. VD2 B: single-phase 220V input connected to L1, L3, and single-phase 220V input connected to L1C, L2C. VD2 B: three-phase 220V input connected to L1, L2, L3. VD2F: single-phase 220V input connected to L1, L2	Connect the main circuit wiring correctly
Internal servo drive fault	Observe whether the monitoring quantity U0-31 (bus voltage) is in the following range: 220V drive: U0-31 less than 200V; 380V drive: U0-31 less than 400V.	Contact technician for repair

Er.22 Main power supply undervoltage

Fault

Servo drive panel display	Fault name
	Main power supply undervoltage

Reason: DC bus voltage is lower than the fault value.

- 220V drive: DC bus voltage normal value is 310V; DC bus voltage fault value is 390V.
- 380V drive: DC bus voltage normal value is 540V; DC bus voltage fault value is 670V.

Troubleshooting

Reason	Troubleshooting methods	Handling
The input voltage is too high	Check whether the drive input power specifications meet the following specifications: 220V drive: Valid value is 198V to 242V. 380V drive: Valid value is 342V to 440V.	Replace or adjust power supply

The power supply is not stable or struck by lightning	Check whether the input power supply of the servo drive meets the specifications and monitor whether it has been struck by lightning.	used after the power supply is stable Connect to surge suppressor
Abnormal braking resistance	Internal brake resistance wiring error: check whether C, D are connected to the short cap and the contact is normal	Connect the short cap or short wire between C and D reliably
	External braking resistor wiring error: Check whether the external resistor is connected reliably between P+ and C.	External braking resistance is reliably strung between P+ and C
	Short-circuit of the built-in brake resistance: Check whether the built-in brake resistance is short-circuited.	Remove the shorting cap between C and D, and reliably string the external braking resistor of equal resistance between P+ and C. Contact technician to replace the internal braking resistor
	The resistance value of the external braking resistor is too large: Check the resistance value of the external braking resistor actually selected and compare it with the recommended braking resistor to confirm whether the resistance value of the actual resistor is too large.	Choose a suitable external braking resistor
The motor is in a state of rapid acceleration and deceleration motion	Monitor the servo drive monitoring quantity U0-31 (bus voltage) to confirm whether the voltage exceeds the fault value when the motor is in the deceleration section.	Ensure that the input voltage is within specification and increase acceleration and deceleration times
Internal servo drive fault	The servo drive is still faulty after power on again	Servo drive may be damaged. Contact technician for repair

Er.23 Braking resistor is not connected

Fault

Servo drive panel display	Fault name
	Braking resistor is not connected

Troubleshooting

Reason	Troubleshooting methods	Handling
Internal brake resistance wiring error	Check whether C, D are connected to the short cap and the contact is normal	When using an internal braking resistor, reliably connect the shorting cap or shorting wire between C and D
External braking resistor wiring error	Check whether the external resistor is connected reliably between P+ and C.	When using an external braking resistor, the external resistor is reliably strung between P+ and C

Internal braking resistor damaged	The servo drive is powered off. Detects whether the resistance between P+ and D is 50Ω	Contact the technician to replace the internal braking resistor. Use an external braking resistor and change the relevant parameters of P00 "Basic Settings".
-----------------------------------	--	--

Er.24 Braking resistor turns on abnormally

Fault

Servo drive panel display	Fault name
	Braking resistor is not connected

Troubleshooting

Reason	Troubleshooting methods	Handling
Internal servo drive fault	The servo drive is still faulty after power on again	Servo drive may be damaged. Contact technician for repair

Er.25 Braking resistor resistance is too large

Fault

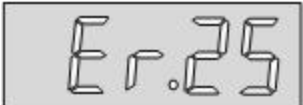
Servo drive panel display	Fault name
	Braking resistor resistance is too large

Troubleshooting

Reason	Troubleshooting methods	Handling
The resistance value of the external braking resistor is too large	Check the resistance value of the external braking resistor actually selected and compare it with the recommended braking resistor to confirm whether the resistance value of the actual resistor is too large.	Choose a suitable external braking resistor
Unreasonable parameter settings	Check whether the value of servo drive P00-10 (external brake resistance) is set too high	Reasonably set the P00-10 (external braking resistor resistance) parameter value
Servo drive firmware fault	Check if the servo drive monitoring quantity U2-04 (firmware version) is in the following range. VD2-0xxSA1G model: earlier than V1.14. VD2F-0xxSA1P model: earlier than V1.02	VD2-0xxSA1G model: Contact manufacturer to upgrade the firmware to V1.14 and above. VD2F-0xxSA1P model: Contact technician to upgrade the firmware to V1.02 and above.

Er.26 Braking resistor resistance is too large

Fault

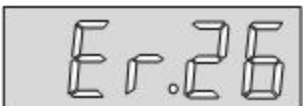
Servo drive panel display	Fault name
	Braking resistor resistance is too large

Troubleshooting

Reason	Troubleshooting methods	Handling
Servo drives do not support this motor	Check whether the servo driver model supports the motor	Contact technical for suitable recommendations of servo drive model or motor model.
Wrong motor model	Check whether the Motor Code is consistent with the Motor nameplate	Contact technician to record the motor Motor Code

Er.27 Encoder disconnection
Fault

Servo drive panel display	Fault name
	Encoder disconnection

Troubleshooting

Reason	Troubleshooting methods	Handling
Poor contact on CN1 port	Check whether the cable port (CN1) of the encoder is properly connected	Tighten the fixing screws on the CN1 port
	Check whether the servo drive CN1 port jack is deformed	If the cable is deformed, replace the cable or its port
Poor contact on adapter port (Rectangular connection cable)	Check whether both ends of the rectangular connector are reliably connected	Make sure that both ends of the rectangular connector are connected reliably; Replace it with an encoder cable with higher connection reliability.
Wrong encoder cable wiring	Check whether the both ends of the encoder cable are correctly connected	Adjust wiring according to the corresponding relationship of pins; The standard encoder cable of the manufacturer is preferred.

Er.28 Encoder Z pulse lost
Fault

Servo drive panel display	Fault name
	Encoder Z pulse lost

Troubleshooting

Reason	Troubleshooting methods	Handling
Wrong motor model	Check whether the Motor Code is consistent with the Motor nameplate	Contact technician to record the motor Motor Code
External interference	Check for strong magnetic fields nearby	Eliminate nearby strong magnetic interference
	Check whether there are sources of interference such as power supply inverter equipment nearby	Separate strong and weak power as much as possible, with good ground contact between motor and servo drive, and keep away from power cable wiring.

Encoder fault	Manually rotate the motor shaft counterclockwise or clockwise to observe whether the monitoring quantity U0-30 (electrical angle) changes regularly	If the value of U0-30 (electrical angle) changes abruptly or does not change, the encoder itself may have problems, please replace the motor or encoder.
---------------	---	--

Er.30 Encoder UVW signal error

Fault

Servo drive panel display	Fault name
	Encoder UVW signal error

Troubleshooting

Reason	Troubleshooting methods	Handling
External interference	Check that the motor and servo drive are well grounded	Motor and servo drive are well grounded
Encoder cable fault	Cross-verification. Use the normal motor, encoder cable to connect to the servo drive.	Replace it with an encoder cable with higher connection reliability.
Servo drive fault	The servo drive is still faulty after power on again	Servo drive may be damaged. Contact technician for repair

Er.31 Power line disconnection

Fault

Servo drive panel display	Fault name
	Power line disconnection

Troubleshooting

Reason	Troubleshooting methods	Handling
The motor power line wiring port is poorly contacted	Check whether the motor power line connection port is connected reliably	Tighten the fixing screws of the motor power line connection ports
The power cable is disconnected	Check the power cable for disconnections at both ends	Replace the power cable and power on again.
Poor contact on adapter port (Rectangular connection cable)	Check whether both ends of the rectangular connector are reliably connected	Make sure that both ends of the rectangular connector are connected reliably; Replace it with an encoder cable with higher connection reliability.

Er.32 Exceeds motor maximum speed

Fault

Servo drive panel display	Fault name
	Exceeds motor maximum speed

Troubleshooting

Reason	Troubleshooting methods	Handling
The UVW phase sequence of motor power cable is incorrect	Check whether the phase sequence of the motor power cable on the servo driver side and motor side corresponds to each other.	Connect correctly according to UVW on the drive side and UVW on the motor side
P01-10 parameter Settings are incorrect	Check that the parameter value of P01-10 (maximum speed threshold) is less than the maximum speed required for the actual operation of the motor	Reset P01-10 (maximum speed threshold) according to mechanical requirements
	Check whether the motor speed corresponding to the input instruction exceeds P01-10 (maximum speed threshold). Position mode, when the instruction is from a pulse instruction (P01-06 = 0). Motor speed (rpm) = input pulse frequency (Hz) * 60 * electronic gear ratio / encoder resolution	
Servo drive fault	The servo drive is still faulty after power on again	Servo drive may be damaged. Please replace the servo drive.

Er.33 Power module is over temperature
Fault

Servo drive panel display	Fault name
	Power module is over temperature

Troubleshooting

Reason	Troubleshooting methods	Handling
Ambient temperature is too high	Measure the ambient temperature	Reduce the ambient temperature of the servo drive
The cooling fan is faulty	Check the servo drive fan for blockage or damage	Contact technician for fan repair or replacement
The servo drive is mounted in an unreasonable orientation or the spacing between the servo drives is unreasonable	Check whether the servo drive installation is reasonable	Contact technical to obtain the installation standard of the servo drive
Servo drive fault	Restarting after 10 minutes of power failure is still reported	Servo drive may be damaged. Please replace the servo drive.

Er.34 Motor overload protection
Fault

Servo drive panel display	Fault name
	Motor overload protection

Troubleshooting

Reason	Troubleshooting methods	Handling
Motor power cable, encoder cable wiring error	Check whether the motor power cable and encoder cable wiring are correct.	Connect them according to the correct connection method. Priority is given to the use of motor power lines and encoder cables as standard by manufacturers
The load is too large	Check overload characteristics of motor or servo drive	Reduce the load. Contact technical to obtain the appropriate capacity drive and motor model.
Frequent acceleration and deceleration	Check whether the acceleration and deceleration motion is frequent or the acceleration and deceleration time is too small	Appropriately extend the acceleration and deceleration time
Motor model and servo driver do not match	Check the monitoring quantity U0-53 (motor model code).	Contact technician to obtain the matching motor model.
Unreasonable parameters	Use Wecon SCTools to obtain the actual torque waveform and observe whether overshoot is obvious	Set the appropriate loop gain parameters
	Observe whether the motor vibrates during operation	Set the appropriate rigidity level
	Check whether p10-04 (Motor overload protection time coefficient) is reasonable	Increase P10-04 (motor overload protection time factor) in the case of ensuring that the motor will not burn out.
Motor blockage	Check if the motor is blocked due to mechanical jamming of the load.	Release the mechanical jam.
The brakes are not open	Check whether the brake device is opened normally, and check whether the output voltage of the brake is 24V	Check the logic of brake power supply or brake output signal
Servo drive fault	The servo drive is still faulty after power on again	Servo drive may be damaged, please contact technician for repair.

Er.35 Electronic gear ratio exceeds limit
Fault

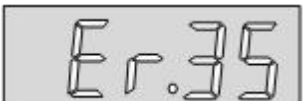
Servo drive panel display	Fault name
	Electronic gear ratio exceeds limit

Troubleshooting

Reason	Troubleshooting methods	Handling
The electronic gear ratio setting is greater than the settable range	Check that the ratio of function codes P01-17/P01-18, P01-19/P01-20 is in the following range. 17bit absolute encoder upper limit value: 500.	After modifying the corresponding function code according to the

	23bit absolute encoder upper limit value: 32000	range, set P10-03 (fault clearance) to 1.
The electronic gear ratio setting is less than the settable range	Check that the ratio of function codes P01-17/P01-18, P01-19/P01-20 is in the following range. 17bit absolute encoder lower limit value: 500.	

Er.36 Position deviation is too large

Fault

Servo drive panel display	Fault name
	Position deviation is too large

Troubleshooting

Reason	Troubleshooting methods	Handling
Cable error	Check whether the phase sequence of the motor power cable on the servo driver side and motor side corresponds to each other.	Connect correctly according to UVW on the drive side and UVW on the motor side
	Check whether both ends of the power cable are disconnected	Replace the power cable and power on again
Unreasonable parameter settings	Check whether P03-02 (Load rigidity Level) is set properly	Reduce the P03-02 (load stiffness level) setting value appropriately
	Check whether the gain parameters are set properly, resulting in overshoot	Adjust gain parameters reasonably
	Check whether P00-25 (position deviation threshold) is set properly	Increase the value of P00-25 (position deviation threshold)
	Use Wecon SCTools to obtain the equivalent speed of the position instruction and check whether the speed is greater than the motor speed limit	Increase the setting values of P01-12 (forward speed threshold) and P01-13 (reverse speed threshold) according to mechanical requirements
Motor blockage	Check if the motor is blocked due to mechanical jamming of the load.	Release the mechanical jam.
The brakes are not open	Check whether the brake device is opened normally, and check whether the output voltage of the brake is 24V	Check the logic of brake power supply or brake output signal
The input pulse frequency is too high	Position mode: when the instruction comes from the pulse instruction (P01-06=0), check whether the input pulse frequency is too high	Reduce the input pulse frequency
The equivalent velocity of position instruction changes too fast	Check if the position instruction changes too fast in the equivalent speed	Properly increase the acceleration and deceleration time and reduce the rate of change of the speed

Er.37 Torque saturation abnormal

Fault

Servo drive panel display	Fault name
	Torque saturation abnormal

Troubleshooting

Reason	Troubleshooting methods	Handling
Motor power line cable UVW phase sequence error	Check whether the phase sequence of the motor power cable on the servo driver side and motor side corresponds to each other.	Connect correctly according to UVW on the drive side and UVW on the motor side
Unreasonable parameter settings	Check whether P01-19 (Torque saturation timeout) is set properly	Increase P01-19 (Torque saturation timeout) setting value appropriately
	Check whether P01-15 (forward torque limit) and P01-16 (reverse torque limit) are set reasonable	Increase the setting values of P01-15 (forward torque limit) and P01-16 (reverse torque limit) appropriately
	Check whether the gain parameters are set properly	Adjust gain parameters reasonably
	Check whether the gain parameters are set properly	Increase the acceleration and deceleration time
The load is too heavy	Check whether the load is too heavy	Reduce the load
Motor blockage	Check whether the motor is blocked due to mechanical jamming of the load.	Release the mechanical jam.
The brakes are not open	Check whether the brake device is opened normally, and check whether the output voltage of the brake is 24V	Check the logic of brake power supply or brake output signal
Limit switches are mounted outside the travel	Check whether the limit switch is installed outside the travel	Adjust the installation position of limit switch

Er.38 Main circuit electricity is lack of phase

Fault

Servo drive panel display	Fault name
	Main circuit electricity is lack of phase

Troubleshooting

Reason	Troubleshooting methods	Handling
Cable error	Check whether the motor power line connection port is connected reliably	Tighten the fixing screws of the motor power line connection ports
	Check the power cable for disconnections at both ends	Replace the power cable and power on again.
Three-phase specification drives run on single-phase power supplies	Check whether the three-phase drive has a single-phase power supply	Connect a three-phase power supply according to the power supply specifications

The power supply is unstable or off	Check that the drive input power specifications meet the specifications: 220V drive valid value: 198V to 242V. 380V drive valid value: 342V to 418V	Use after the power supply is stable.
Servo drive fault	The servo drive is still faulty after power on again	Servo drive may be damaged, please contact technician for repair.

Er.39 Emergency stop

Fault

Servo drive panel display	Fault name
	Emergency stop

Troubleshooting

Reason	Troubleshooting methods	Handling
Servo drive receives emergency stop instructions	Check whether emergency stop protection is triggered manually	Power on the servo drive again
	Check whether the servo drive has mistakenly triggered the emergency stop signal. Check whether function 08 (E-STOP) is configured in the P06 group "DIDO configuration" function code group "DI port function selection" and whether the DI port wiring is normal.	Properly wire the DI port

Er.40 Encoder battery failure

Fault

Servo drive panel display	Fault name
	Encoder battery failure

Troubleshooting

Reason	Troubleshooting methods	Handling
Multi-turn absolute encoder is not connected to the battery during the power off of the servo drive	Check if the encoder is connected to the battery during the power off of the servo	Set P10-03 (Fault clearing) to 1
The voltage of multi-turn absolute encoder battery is low	Measure battery voltage	Contact technicians to replace with a new encoder battery

Er.41 Motor (encoder) over temperature

Fault

Servo drive panel display	Fault name
	Motor (encoder) over temperature

Troubleshooting

Reason	Troubleshooting methods	Handling
The motor is overloaded	Check whether the motor is overloaded	Reduce the load of the motor

Er.42 Encoder write fault fault

Fault

Servo drive panel display	Fault name
	Encoder write faults

Troubleshooting

Reason	Troubleshooting methods	Handling
Poor contact of CN1 port	Check whether the cable port (CN1) of the encoder is properly connected	Tighten the fixing screws on the CN1 port
	Check whether the servo drive CN1 port jack is deformed	If the cable is deformed, replace the cable or its port
Poor contact on adapter port (Rectangular connection cable)	Check whether both ends of the rectangular connector are reliably connected	Make sure that both ends of the rectangular connector are connected reliably; Replace it with an encoder cable with higher connection reliability.
External interference	Check for strong magnetic fields nearby	Eliminate nearby strong magnetic interference
	Check whether there are sources of interference such as power supply inverter equipment nearby	Separate strong and weak power as much as possible, with good ground contact between motor and servo drive, and keep away from power cable wiring.
Servo drive fault	The servo drive is still faulty after power on again	Servo drive may be damaged, please contact technician for repair.

Er.43 Drive overload fault

Fault phenomenon

Servo drive panel display	Fault name
	Drive overload fault

Troubleshooting

Reason	Troubleshooting	Handling
The average output power (U0-34) exceeds the limit power (overload 110%) for more than 20 minutes.	Whether the average output power (U0-34) often exceeds the limit (overload 110) Check whether the drive meets the requirements.	Observed whether the U0-34 is often greater than the servo limit power (overload 110%) during servo operation. When ER.43 alarm is found in the process of machine adjustment, please check whether the servo power is suitable. It is recommended to replace the driver model with higher power.
Servo drive fault	The servo drive is still faulty after power on again	Servo drive may be damaged, contact the manufacturer's technician for

		repair.
--	--	---------

Er.45 Drive Stall Overtemperature Protection

(1) Fault phenomenon

Servo drive panel display	Fault name
	Drive Stall Overtemperature Protection

(2) Troubleshooting

Reason	Troubleshooting	Treatment
Check whether U0-39 load torque percentage exceeds the maximum torque of the motor for 3 seconds or observe whether the load torque at the waveform interface of the oscilloscope of SCTool is greater than the maximum torque of the motor and the motor is stalled.	Check whether U0-39 load torque percentage exceeds the maximum torque of the motor, and observe whether the motor is stuck.	Observe maximum torque observes whether the load torque on the waveform interface of SCTool oscilloscope is greater than the motor maximum torque or check whether U0-39 load torque percentage exceeds the motor maximum torque for 3 seconds.

Drive Model	Rated Power/W	Limit Power/W (Overload 110%)
VD2-010SA1G/SA1H	400	440
VD2-014SA1G/SA1H	750	825
VD2-016SA1G/SA1H	1500	1650
VD2-019SA1G/SA1H	2300	2530
VD2-021SA1G/SA1H	2300	2530
VD2-025SA1G/SA1H	2600	2860
VD2-030SA1G/SA1H	2600	2860
VD2F-010SA1G	400	440
VD2F-014SA1G	750	825
VD2-021TA1G	3000	3300

Er.60 ADC conversion is not complete

Fault

Servo drive panel display	Fault name
---------------------------	------------

	ADC conversion is not complete
---	--------------------------------

Troubleshooting

Reason	Troubleshooting methods	Handling
External interference	Check for strong magnetic fields nearby	Eliminate nearby strong magnetic interference
	Check whether there are sources of interference such as power supply inverter equipment nearby	Separate strong and weak power as much as possible, with good ground contact between motor and servo drive, and keep away from power cable wiring.
Servo drive fault	Factory reset the parameter (P10-02=1) and power on again. If the servo drive still alarms after multiple operations, it is faulty.	If there is still alarm after multiple power-on, contact the technician.

Er.61 Internal software fault

Fault

Servo drive panel display	Fault name
	Internal software fault

Troubleshooting

Reason	Troubleshooting methods	Handling
Servo drive fault	Factory reset the parameter (P10-02=1) and power on again. If the servo drive still alarms after multiple operations, it is faulty.	If there is still alarm after multiple power-on, contact the technician.

Er.62 Internal software fault

Fault

Servo drive panel display	Fault name
	Internal software fault

Troubleshooting

Reason	Troubleshooting methods	Handling
Servo drive fault	Factory reset the parameter (P10-02=1) and power on again. If the servo drive still alarms after multiple operations, it is faulty.	If there is still alarm after multiple power-on, contact the technician.

Er.63 Internal software fault

Fault

Servo drive panel display	Fault name
	Internal software fault

Troubleshooting

Reason	Troubleshooting methods	Handling
Servo drive fault	Factory reset the parameter (P10-02=1) and power on again. If the servo drive still alarms after multiple operations, it is faulty.	If there is still alarm after multiple power-on, contact the technician.

Er.64 Internal software fault

Fault

Servo drive panel display	Fault name
	Internal software fault

Troubleshooting

Reason	Troubleshooting methods	Handling
Servo drive fault	Factory reset the parameter (P10-02=1) and power on again. If the servo drive still alarms after multiple operations, it is faulty.	If there is still alarm after multiple power-on, contact the technician.

Er.65 Internal software fault

Fault

Servo drive panel display	Fault name
	Internal software fault

Troubleshooting

Reason	Troubleshooting methods	Handling
Servo drive fault	Factory reset the parameter (P10-02=1) and power on again. If the servo drive still alarms after multiple operations, it is faulty.	If there is still alarm after multiple power-on, contact the technician.

A-80 Drive overpower warning

Fault

Servo drive panel display	Alarm name
	Drive overpower warning

(2) Troubleshooting

Reason	Troubleshooting	Handling
The average output power (U0-34) exceeds the limit power of the drive (overload 110%) for more than 5 seconds, the drive will have alarm.	Check whether the average output power (U0-34) exceeds the limit (overload 110%) The average output power (U0-34) exceeds the limit power (overload 110%) for more than 5 minutes. Check whether the U0-34 exceeds 110% of the rated power of the driver.	Check whether the U0-34 exceeds 110% of the rated power of the driver. When A80 alarm is found in the process of machine adjustment, please check whether the servo power is suitable.

Drive Model	Rated Power/W	Limit Power/W (Overload 110%)
VD2-010SA1G/SA1H	400	440
VD2-014SA1G/SA1H	750	825
VD2-016SA1G/SA1H	1500	1650
VD2-019SA1G/SA1H	2300	2530
VD2-021SA1G/SA1H	2300	2530
VD2-025SA1G/SA1H	2600	2860
VD2-030SA1G/SA1H	2600	2860
VD2F-010SA1G	400	440
VD2F-014SA1G	750	825
VD2-021TA1G	3000	3300

A-81 Overspeed alarm

Fault

Servo drive panel display	Fault name
	Overspeed alarm

Troubleshooting

Reason	Troubleshooting methods	Handling
Motor power line cable UVW phase sequence error	Check whether the phase sequence of the motor power cable on the servo driver side and motor side corresponds to each other.	Connect correctly according to UVW on the drive side and UVW on the motor side
P01-11 parameter setting is not proper	Check whether the value of P01-11 (warning speed threshold) is less than the max speed required for the operation of motor	Reset P01-11 (warning speed threshold) according to mechanical requirements

Input speed command is too high	Check whether the motor speed corresponding to the input command exceeds P01-11 (maximum speed threshold)	Reduce the input speed instruction according to the mechanical requirements; Reasonably increase P01-11 (warning speed threshold)
---------------------------------	---	---

A-82 Overload

Fault

Servo drive panel display	Fault name
	Overload

Troubleshooting

Reason	Troubleshooting methods	Handling
Motor power cable, encoder cable wiring error	Check whether the motor power cable and encoder cable wiring are correct.	Connect them according to the correct connection method. Priority is given to the use of motor power lines and encoder cables as standard by manufacturers
The load is too large	Check overload characteristics of motor or servo drive	Reduce the load. Contact technical to obtain the appropriate capacity drive and motor model.
Frequent acceleration and deceleration	Check whether the acceleration and deceleration motion is frequent or the acceleration and deceleration time is too small	Appropriately extend the acceleration and deceleration time
Motor model and servo driver do not match	Perform inertia identification and check the inertia ratio.	Contact technician to obtain the matching motor model.
Motor model and servo driver do not match	Check the monitoring quantity U0-53 (motor model code).	Contact technician to obtain the matching motor model.
Unreasonable parameters	Use Wecon SCTools to obtain the actual torque waveform and observe whether overshoot is obvious	Set the appropriate loop gain parameters
	Observe whether the motor vibrates during operation	Set the appropriate rigidity level

A-83 Braking resistor is over temperature or overloaded

Fault

Servo drive panel display	Fault name
	Braking resistor is over temperature or overloaded

Troubleshooting

Reason	Troubleshooting methods	Handling
Improper connection of internal braking resistor	Check whether C, D are connected to the short cap and the contact is normal	When using an internal braking resistor, reliably connect the shorting cap or shorting wire between C and D
Improper connection of external braking resistor	Remove the external braking resistor and measure whether the resistance value is " ∞ " (infinity)	Replace the new external braking resistor. After ensuring that the resistance value of the resistor is the same as the nominal value, connect it in series between P+ and C.

The resistance value of the external braking resistor is too large	Test the actual external braking resistor resistance and compare it with the recommended braking resistor to make sure the actual resistance is not too large.	Use a suitable external braking resistor.
Improper parameter setting	When using an external braking resistor, check the following parameters. Whether P00-09 (braking resistor setting) is reasonable. P00-10 (external braking resistor resistance value) is reasonable.	Reasonable setting of P00-09 (braking resistor setting): P00-09=1 (use external braking resistor and natural cooling) P00-09 = 3 (do not use the braking resistor, all by capacitor absorption) P00-10 (external braking resistor resistance value) parameter value and the actual use of external braking resistor are consistent.

A-84 Parameter modification that needs to be powered on again

Fault

Servo drive panel display	Fault name
	Braking resistor is over temperature or overloaded

Troubleshooting

Reason	Troubleshooting methods	Handling
Modified the effective timing to "power on again" parameter.	Check whether the servo drive has modified the parameter with the effective time "power on again".	Power on again

A-85 Receive position pulse when servo is OFF

Fault

Servo drive panel display	Fault name
	Receive position pulse when servo is OFF

Troubleshooting

Reason	Troubleshooting methods	Handling
Servo received position pulse when it is OFF.	Check whether the servo drive is in the OFF state, and check whether the host computer is sending pulse instruction.	The host computer stops sending pulse instructions.
Servo received pulse instruction in non-position mode	Check whether the servo drive P00-01 (control mode) is in position mode; Check whether the host computer is sending pulse instructions	

A-86 Input pulse frequency is too high

Fault

Servo drive panel display	Fault name
	Input pulse frequency is too high

Troubleshooting

Reason	Troubleshooting methods	Handling
The input pulse frequency is too high	Position mode; When the instruction source is pulse instructions (P01-06=0), check whether the input pulse frequency is too high	Reduce the input pulse frequency
Improper parameter setting	Check whether the parameter value of P01-16 (number of instruction pulses for one rotation of the motor) is greater than the actual demand value.	Reset P01-16 according to mechanical requirements (number of instruction pulses for one rotation of motor).
	Check whether the parameter value of P01-17 to P01-20 (electronic gear ratio) is greater than the actual demand value.	Reset parameter of values P01-17 to P01-20 (electronic gear ratio) according to mechanical requirements

A-88 Main circuit momentary power off

Fault

Servo drive panel display	Fault name
	Main circuit momentary power off

Troubleshooting

Reason	Troubleshooting methods	Handling
Power off	Check that the drive input power specifications meet the specifications: 220V drive valid value: 198V to 242V. 380V drive valid value: 342V to 418V	Use it after the power supply is stable
Servo drive fault	The servo drive is still faulty after power on again	Servo drive may be damaged, please contact technician for repair.

A-89 DI port configuration is duplicate

Fault

Servo drive panel display	Fault name
	DI port configuration is duplicate

Troubleshooting

Reason	Troubleshooting methods	Handling
The same non-zero DI function is assigned to multiple DI ports	Check whether the "DI port function selection" of the "DIDO Configuration" function code group of the P06 group is configured with the same DI function	Configuring each DI port for different DI functions and power on again. Configure the function of the unwanted DI ports to 0 (off) and power on again. Factory reset the parameter P10-02=1, and power on again.

A-90 DI port configuration is duplicate

Fault

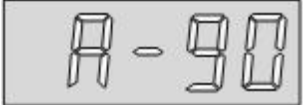
Servo drive panel display	Fault name
	DO port configuration i duplicate

Troubleshooting

Reason	Troubleshooting methods	Handling
The same non-zero DO function is assigned to multiple DO ports	Check whether the "DO port function selection" of the "DIDO Configuration" function code group of the P06 group is configured with the same DO function	Configuring each DO port for different DO functions and power on again. Configure the function of the unwanted DO ports to 0 (off) and power on again. Factory reset the parameter P10-02=1, and power on again.

A-91 Parameter modification is too frequent

Fault

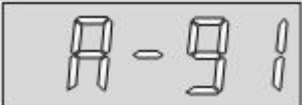
Servo drive panel display	Fault name
	Parameter modification is too frequent (modification frequency allowed of function code: 6 hours/150 times Note: 32-bit function code: recorded as 2 times)

Troubleshooting

Reason	Troubleshooting	Handling
EEPROM writing frequency is too high	Check whether the host computer frequently modifies the parameters (modification frequency allowed of function code: 6 hours/150 times Note: 32-bit function code: recorded as 2 times)	(1) During machine adjustment, A91 warning (6 hours/150 times) caused by manual frequent modification of function codes can be cleared through P10-03. In other cases, please check the PLC program (2) If A91 warning appears in the normal working mode of the machine, please check whether the PLC program frequently modifies the function code.

		(3) When the function code needs to be modified frequently, it is recommended to close Modbus write to EEPROM (P12-4 is set to 0)
external interference	Check for strong magnetic fields nearby	Eliminate nearby strong magnetic interference
	Check whether there are sources of interference such as power supply inverter equipment nearby	Separate strong and weak power as much as possible, with good ground contact between motor and servo drive, and keep away from power cable wiring.
	Increase the abnormal threshold setting of P0-31 encoder read-write check.	Eliminate the A93 warning by increasing the exception threshold is suitable as a temporary solution. The disadvantage is that the motor may run in an unstable state.
Encoder fault	Manually rotate the motor shaft counterclockwise or clockwise to observe whether the monitoring quantity U0-30 (electrical angle) changes regularly	If the value of U0-30 (electrical angle) changes abruptly or does not change, the encoder itself may have problems, please replace the motor or encoder.
Servo drive fault	<ul style="list-style-type: none"> •Cross-verification. Use the normal motor, encoder cable to connect to the servo drive. If the servo drive still have alarm, it is servo fault. 	Servo driver may be damaged, please contact the manufacturer's technician.

A-92 Low encoder battery voltage warning

Fault

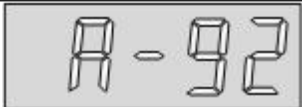
Servo drive panel display	Fault name
	Low encoder battery voltage warning

Troubleshooting

Reason	Troubleshooting methods	Handling
The encoder battery voltage is less than 3.1V	Measure the encoder battery voltage	Contact technician to replace a new encoder battery

A-93 Abnormal and frequency of encoder read and write check is too high

Fault

Servo drive panel display	Fault name
	Abnormal and frequency of encoder read and write check is too high

Troubleshooting

Reason	Troubleshooting methods	Handling
External interference	Check for strong magnetic fields nearby	Eliminate nearby strong magnetic interference
	Check whether there are sources of interference such as power supply inverter equipment nearby	Separate strong and weak power as much as possible, with good ground contact between motor and servo drive, and keep away from power cable wiring.

Internal servo drive fault	Cross-verification. Use the normal motor, encoder cable to connect to the servo drive, only connect the encoder cable. If the servo drive still alarm, it is failure.	Contact technician for repair
----------------------------	---	-------------------------------

11. Appendix

11.1 Lists of parameters

In order to facilitate your use, the VD2SA series provides monitoring display and setting display functions. The specification are as follows.

Number	Parameter group name	Parameter group	Range
1	Basic settings	Group P00	P00-01 to P00-30
2	Control parameters	Group P01	P01-01 to P01-33
3	Gain adjustment	Group P02	P02-01 to P02-12
4	Self-adjustment parameters	Group P03	P03-01 to P03-08
5	Vibration suppression	Group P04	P04-01 to P04-10
6	Signal input and output	Group P05	P05-01 to P05-21
7	DI / DO configuration	Group P06	P06-02 to P06-33
8	Multi-segment position	Group P07	P07-01 to P07-72
9	Accessibility	Group P10	P10-01 to P10-06
10	Communication parameters	Group P12	P12-01 to P12-05
11	Communication input and output	Group P13	P13-01 to P13-14
12	Universal	Group U0	U0-01 to U0-56
13	Warning	Group U1	U1-01 to U1-25
14	Device	Group U2	U2-01 to U2-16

Comments about the contents of the parameter table

(1) Parameter name

If a parameter name is “reserved”, it is occupied by system. Please do not configure the parameter.

If a parameter name is “not supported”, it means that the model does not support the parameter.

For the difference of servo drive parameters of different models, please refer to the parameter table.

(2) Parameter unit

If a parameter unit is “-”, it has no unit.

(3) The time when the modification takes effect

Some of parameters need to be powered on again to take effect. Please refer to the parameter table.



The following parameter table is described in terms of VD2-014SA1G model V1.13 firmware version. Some of the parameters are different from the old version.

Group P00 Basic settings

Function code	Name	Setting method	Effective time	Default	Range	Unit	Modbus address		Data type
							Hexadecimal	Decimal	
P00-01	Control mode	Shutdown setting	Effective immediately	1	1 to 6	-	0x0001	1	16-bit
P00-04	Rotation direction	Shutdown setting	Effective immediately	0	0 to 1	-	0x0004	4	16-bit
P00-05	Servo OFF shutdown mode	Shutdown setting	Effective immediately	0	0 to 1	-	0x0005	5	16-bit
P00-09	Braking resistance setting	Operation setting	Effective immediately	0	0 to 3	-	0x0009	9	16-bit
P00-10	External braking resistor resistance	Operation setting	Effective immediately	50	0 to 65535	Ω	0x000A	10	16-bit
P00-11	External braking resistor power	Operation setting	Effective immediately	100	0 to 65535	W	0x000B	11	16-bit
P00-12	Position pulse type selection	Operation setting	Power-on again	0	0 to 5	-	0x000C	12	16-bit
P00-13	Maximum position pulse frequency	Shutdown setting	Effective immediately	300	1 to 500	kHz	0x000D	13	16-bit
P00-14	Position pulse anti-interference grade	Operation setting	Power-on again	2	0 to 9	-	0x000E	14	16-bit
P00-16	Number of instruction pulses when the motor rotates one circle	Shutdown setting	Effective immediately	10000	0 to 131072	Instruction pulse unit	0x0010	16	32-bit
P00-17	Electronic gear 1 numerator	Operation setting	Effective immediately	1	1 to 4294967294	-	0x0012	18	32-bit
P00-18	Electronic gear 1 denominator	Operation setting	Effective immediately	1	1 to 4294967294	-	0x0014	20	32-bit
P00-19	Electronic Gear 2 nominator	Operation setting	Effective immediately	1	1 to 4294967294	-	0x0016	22	32-bit
P00-20	Electronic gear 2 denominator	Operation setting	Effective immediately	1	1 to 4294967294	-	0x0018	24	32-bit
P00-21	Pulse frequency division output direction	Operation setting	Power-on again	0	0 to 1	-	0x001A	26	16-bit
P00-22	Number of output pulses when the motor rotates one circle	Operation setting	Power-on again	2500	0 to 2500	Pulse unit	0x001B	27	16-bit
P00-23	Z pulse output OZ polarity	Operation setting	Power-on again	0	0 to 1	-	0x001C	28	16-bit
P00-24	Z pulse output	Operation setting	Power-on again	3	0-200	ms	0x001D	29	16-bit
P00-25	Position deviation limit	Shutdown setting	Effective immediately	60000	0 to 2147483646	Equivalent pulse unit	0x001E	30	32-bit
P00-27	Pulse output frequency division numerator	Operation setting	Power-on again	1	1 to 2500	-	0x0021	33	16-bit

P00-28	Pulse output frequency division denominator	Operation setting	Power-on again	1	1 to 2500	-	0x0022	34	16-bit
P00-29	Number of equivalent position unit in a circle	Shutdown setting	Effective immediately	10000	0 to 131072	-	0x0023	35	32-bit
P00-30	Shield multi-turn absolute encoder battery fault	Operation setting	Power-on again	0	0 to 1	-	0x0025	37	16-bit
P00-31	Encoder read-write verification exception threshold setting	Operation setting	Effective immediately	20	0 to 100	-	0x0026	38	16-bit

Group P01 Control parameter

Function code	Name	Setting method	Effective time	Default	Range	Unit	Modbus address		Data type
							Hexadecimal	Decimal	
P01-01	Speed instruction source	Shutdown setting	Effective immediately	0	0 to 1	-	0x0101	257	16-bit
P01-02	Internal speed instruction 0	Operation setting	Effective immediately	0	-5000 to 5000	rpm	0x0102	258	16-bit
P01-03	Acceleration time	Operation setting	Effective immediately	50	0 to 65535	ms	0x0103	259	16-bit
P01-04	Deceleration time	Operation setting	Effective immediately	50	0 to 65535	ms	0x0104	260	16-bit
P01-05	Shutdown deceleration time	Shutdown setting	Effective immediately	50	0 to 65535	ms	0x0105	261	16-bit
P01-06	Position instruction source	Operation setting	Effective immediately	0	0 to 1	-	0x0106	262	16-bit
P01-07	Torque instruction source	Shutdown setting	Effective immediately	0	0 to 1	-	0x0107	263	16-bit
P01-08	Torque instruction keyboard setting value	Operation setting	Effective immediately	0	-3000 to 3000	0.1%	0x0108	264	16-bit
P01-09	Source of speed limit in torque mode	Shutdown setting	Effective immediately	0	0 to 1	-	0x0109	265	16-bit
P01-10	Maximum speed threshold	Operation setting	Effective immediately	3600	0 to 5000	rpm	0x010A	266	16-bit
P01-11	Warning speed threshold	Operation setting	Effective immediately	3300	0 to 5000	rpm	0x010B	267	16-bit
P01-12	Forward speed threshold	Operation setting	Effective immediately	3000	0 to 5000	rpm	0x010C	268	16-bit
P01-13	Reverse speed threshold	Operation setting	Effective immediately	3000	0 to 5000	rpm	0x010D	269	16-bit
P01-14	Torque limit source	Shutdown setting	Effective immediately	0	0 to 1	-	0x010E	270	16-bit
P01-15	Forward torque limit	Operation setting	Effective immediately	3000	0 to 3000	0.1%	0x010F	271	16-bit
P01-16	Reverse torque limit	Operation setting	Effective immediately	3000	0 to 3000	0.1%	0x0110	272	16-bit
P01-17	Forward torque limit in torque mode	Operation setting	Effective immediately	3000	0 to 5000	rpm	0x0111	273	16-bit

(Full V1.1)

P01-18	Reverse torque limit in torque mode	Operation setting	Effective immediately	3000	0 to 5000	rpm	0x0112	274	16-bit
P01-19	Torque saturation timeout period	Operation setting	Effective immediately	3000	0 to 65535	ms	0x0113	275	16-bit
P01-21	Zero-speed clamp function selection	Operation setting	Effective immediately	3000	0 to 3	rpm	0x0112	277	16-bit
P01-22	Zero speed clamp speed threshold	Operation setting	Effective immediately	20	0 to 5000	ms	0x0113	278	16-bit
P01-23	Internal speed instruction 1	Operation setting	Effective immediately	0	0 to 3	-	0x0115	279	16-bit
P01-24	Internal speed instruction 2	Operation setting	Effective immediately	20	-5000 to 5000	rpm	0x0116	280	16-bit
P01-25	Internal speed instruction 3	Operation setting	Effective immediately	0	-5000 to 5000	rpm	0x0117	279	16-bit
P01-26	Internal speed instruction 4	Operation setting	Effective immediately	0	-5000 to 5000	rpm	0x0118	280	16-bit
P01-27	Internal speed instruction 5	Operation setting	Effective immediately	0	-5000 to 5000	rpm	0x0119	281	16-bit
P01-28	Internal speed instruction 6	Operation setting	Effective immediately	0	-5000 to 5000	rpm	0x011A	282	16-bit
P01-29	Internal speed instruction 7	Operation setting	Effective immediately	0	-5000 to 5000	rpm	0x011B	283	16-bit
P01-30	Delay from brake output ON to instruction reception	Operation setting	Effective immediately	0	0 to 500	ms	0x011C	284	16-bit
P01-31	In the static state, delay from the brake output is OFF to the motor is not energized.	Operation setting	Effective immediately	0	1 to 1000	ms	0x011D	285	16-bit
P01-32	Rotation state, when the brake output is OFF, the speed threshold	Operation setting	Effective immediately	250	0 to 3000	rpm	0x011E	286	16-bit
P01-33	Rotation status, delay from servo enable OFF to brake output OFF	Operation setting	Effective immediately	150	1 to 1000	ms	0x011F	287	16-bit

Group P02 Gain adjustment

Function code	Name	Setting method	Effective time	Default	Range	Unit	Modbus address		Data type
							Hexadecimal	Decimal	
P02-01	1st position loop gain	Operation setting	Effective immediately	400	0 to 6200	0.1Hz	0x0201	513	16-bit
P02-02	1st speed loop gain	Operation setting	Effective immediately	65	0 to 35000	0.1Hz	0x0202	514	16-bit
P02-03	1st speed loop integral time constant	Operation setting	Effective immediately	1000	100 to 65535	0.1ms	0x0203	515	16-bit
P02-04	2nd position loop gain	Operation setting	Effective immediately	35	0 to 6200	0.1Hz	0x0204	516	16-bit
P02-05	2nd speed loop gain	Operation setting	Effective immediately	65	0 to 35000	0.1Hz	0x0205	517	16-bit
P02-06	2nd speed loop integral time constant	Operation setting	Effective immediately	1000	0 to 65535	0.1ms	0x0206	518	16-bit
P02-07	2nd gain switching mode	Operation setting	Effective immediately	0	0 to 3	-	0x0207	519	16-bit
P02-08	Gain switching condition selection	Operation setting	Effective immediately	0	0 to 10		0x0208	520	16-bit
P02-09	Speed feedforward gain	Operation setting	Effective immediately	0	0 to 1000	0.1%	0x0209	521	16-bit
P02-10	Speed feedforward filter time constant	Operation setting	Effective immediately	50	0 to 10000	0.01ms	0x020A	522	16-bit
P02-11	Torque feedforward gain	Operation setting	Effective immediately	0	0 to 2000	0.1%	0x020B	523	16-bit
P02-12	Torque feedforward filter time constant	Operation setting	Effective immediately	50	0 to 10000	0.01ms	0x020C	524	16-bit
P02-13	Delay Time for Gain Switching	Operation setting	Effective immediately	20	0 to 10000	0.1ms	0x020D	525	16-bit
P02-14	Gain switching grade	Operation setting	Effective immediately	50	0 to 20000		0x020E	526	16-bit
P02-15	Gain switching hysteresis	Operation setting	Effective immediately	20	0 to 20000		0x020F	527	16-bit
P02-16	Position loop gain switching time	Operation setting	Effective immediately	30	0 to 10000	0.1ms	0x0210	528	16-bit
P02-20	Enable model tracking control function	Shutdown setting	Effective immediately	0	0 to 1		0x0214	532	16-bit
P02-21	Model tracking control gain	Shutdown setting	Effective immediately	1000	200 to 20000	0.1/s	0x0215	533	16-bit
P02-22	Model tracking control gain compensation	Shutdown setting	Effective immediately	1000	500 to 2000	0.10%	0x0216	534	16-bit
P02-23	Model tracking control forward rotation bias	Shutdown setting	Effective immediately	1000	0 to 10000	0.10%	0x0217	535	16-bit
P02-24	Model tracking control reverses rotation bias	Shutdown setting	Effective immediately	1000	0 to 10000	0.10%	0x0218	536	16-bit

P02-25	Model tracking control speed feedforward compensation	Shutdown setting	Effective immediately	1000	0 to 10000	0.10%	0x0219	537	16-bit
------------------------	---	------------------	-----------------------	------	------------	-------	--------	-----	--------

Group P03 Self-adjustment parameters

Function code	Name	Setting method	Effective time	Default	Range	Unit	Modbus address		Data type
							Hexadecimal	Decimal	
P03-01	Load inertia ratio	Operation setting	Effective immediately	300	100 to 10000	0.01	0x0301	769	16-bit
P03-02	Load rigidity grade selection	Operation setting	Effective immediately	14	0 to 31	-	0x0302	770	16-bit
P03-03	Self-adjusting mode selection	Operation setting	Effective immediately	0	0 to 2	-	0x0303	771	16-bit
P03-04	Online inertia recognition sensitivity	Operation setting	Effective immediately	0	0 to 2	-	0x0304	772	16-bit
P03-05	Number of cycles of inertia recognition	Shutdown setting	Effective immediately	2	1 to 20	Circle	0x0305	773	16-bit
P03-06	Maximum speed of inertia recognition	Shutdown setting	Effective immediately	1000	300 to 2000	rpm	0x0306	774	16-bit
P03-07	Parameter identification of rotation direction	Shutdown setting	Effective immediately	0	0 to 2	-	0x0307	775	16-bit
P03-08	Parameter identification waiting time	Shutdown setting	Effective immediately	1000	300 to 10000	ms	0x0308	776	16-bit

Group P04 Vibration suppression

Function code	Name	Setting method	Effective time	Default	Range	Unit	Modbus address		Data type
							Hexadecimal	Decimal	
P04-01	Pulse instruction filtering method	Shutdown setting	Effective immediately	0	0 to 1	-	0x0401	1025	16-bit
P04-02	Position instruction first-order low-pass filtering time constant	Shutdown setting	Effective immediately	0	0 to 1000	ms	0x0402	1026	16-bit
P04-03	Position instruction average filter time constant	Shutdown setting	Effective immediately	0	0 to 128	ms	0x0403	1027	16-bit
P04-04	Torque filter time constant	Operation setting	Effective immediately	50	10 to 2500	0.01ms	0x0404	1028	16-bit
P04-05	1st notch filter frequency	Operation setting	Effective immediately	300	250 to 5000	Hz	0x0405	1029	16-bit
P04-06	1st notch filter depth	Operation setting	Effective immediately	100	0 to 100	-	0x0406	1030	16-bit
P04-07	1st notch filter width	Operation setting	Effective immediately	4	0 to 12	-	0x0407	1031	16-bit
P04-08	2nd notch filter frequency	Operation setting	Effective immediately	500	250 to 5000	Hz	0x0408	1032	16-bit
P04-09	2nd notch filter depth	Operation setting	Effective immediately	100	0 to 100	-	0x0409	1033	16-bit
P04-10	2nd notch filter width	Operation setting	Effective immediately	4	0 to 12	-	0x040A	1034	16-bit
P04-11	Enable low-frequency vibration suppression function	Operation setting	Effective immediately	4	0 to 1	-	0x040B	1035	16-bit
P04-12	Low-frequency vibration suppression frequency	Operation setting	Effective immediately	800	10 to 2000	0.1HZ	0x040C	1036	16-bit
P04-14	Shutdown vibration detection amplitude	Operation setting	Effective immediately	100	0 to 3000	0.001	0x040E	1038	16-bit
P04-18	Speed feedback filtering time	Operation setting	Effective immediately	40	20 to 1000	0.01ms	0x0412	1042	16-bit
P04-19	Enable the type A suppression function	Operation setting	Effective immediately	0	0 to 1	-	0x0413	1043	16-bit
P04-20	Type A suppression frequency	Operation setting	Effective immediately	1000	100 to 20000	0.1HZ	0x0414	1044	16-bit
P04-21	Type A suppression gain correction	Operation setting	Effective immediately	100	0 to 1000	0.01	0x0415	1045	16-bit
P04-22	Type A suppression damping gain	Operation setting	Effective immediately	0	0 to 500	0.01	0x0416	1046	16-bit
P04-23	Type A suppression phase correction	Operation setting	Effective immediately	200	0 to 900	0.1 degree	0x0417	1047	16-bit

Group P05 Signal input and output

Function code	Name	Setting method	Effective time	Default	Range	Unit	Modbus address		Data type
							Hexadecimal	Decimal	
P05-01	AI_1 input bias	Operation setting	Effective immediately	0	-5000 to 5000	mV	0x0501	1281	16-bit
P05-02	AI_1 input filter time constant	Operation setting	Effective immediately	200	0 to 60000	0.01ms	0x0502	1282	16-bit
P05-03	AI_1 dead zone	Operation setting	Effective immediately	20	0 to 1000	mV	0x0503	1283	16-bit
P05-04	AI_1 zero drift	Operation setting	Effective immediately	0	-500 to 500	mV	0x0504	1284	16-bit
P05-05	AI_2 input bias	Operation setting	Effective immediately	0	-5000 to 5000	mV	0x0505	1285	16-bit
P05-06	AI_2 input filter time constant	Operation setting	Effective immediately	200	0 to 60000	0.01ms	0x0506	1286	16-bit
P05-07	AI_2 dead zone	Operation setting	Effective immediately	20	0 to 500	mV	0x0507	1287	16-bit
P05-08	AI_2 zero drift	Operation setting	Effective immediately	0	-500 to 500	mV	0x0508	1288	16-bit
P05-09	Analog quantity 10V for speed value	Shutdown setting	Effective immediately	3000	100 to 4500	rpm	0x0509	1289	16-bit
P05-10	Analog quantity 10V for torque value	Shutdown setting	Effective immediately	1000	0 to 3000	0.1%	0x050A	1290	16-bit
P05-11	Positioning is completed, positioning close condition setting	Operation setting	Effective immediately	0	0 to 3	-	0x050B	1291	16-bit
P05-12	Positioning completion threshold	Operation setting	Effective immediately	800	1 to 65535	Equivalent pulse unit	0x050C	1292	16-bit
P05-13	Positioning approach threshold	Operation setting	Effective immediately	5000	1 to 65535	Equivalent pulse unit	0x050D	1293	16-bit
P05-14	Position detection window time	Operation setting	Effective immediately	10	0 to 20000	ms	0x050E	1294	16-bit
P05-15	Positioning signal hold time	Operation setting	Effective immediately	100	0 to 20000	ms	0x050F	1295	16-bit
P05-16	Rotation detection speed threshold	Operation setting	Effective immediately	20	0 to 1000	rpm	0x0510	1296	16-bit
P05-17	Speed consistent signal threshold	Operation setting	Effective immediately	10	0 to 100	rpm	0x0511	1297	16-bit
P05-18	Speed approach signal threshold	Operation setting	Effective immediately	100	10 to 6000	rpm	0x0512	1298	16-bit
P05-19	Zero speed output signal threshold	Operation setting	Effective immediately	10	0 to 6000	rpm	0x0513	1299	16-bit
P05-20	Torque arrival threshold	Operation setting	Effective immediately	100	0 to 300	%	0x0514	1300	16-bit
P05-21	Torque arrival hysteresis value	Operation setting	Effective immediately	10	0 to 20	%	0x0515	1301	16-bit

Group P06 DIDO configuration

Function code	Name	Setting method	Effective time	Default	Range	Unit	Modbus address		Data type
							Hexadecimal	Decimal	
P06-02	DI_1 channel function selection	Operation setting	Power-on again	1	0 to 32	-	0x0602	1538	16-bit
P06-03	DI_1 channel logic selection	Operation setting	Effective immediately	0	0 to 1	-	0x0603	1539	16-bit
P06-04	DI_1 input source selection	Operation setting	Effective immediately	0	0 to 1	-	0x0604	1540	16-bit
P06-05	DI_2 channel function selection	Operation setting	Power-on again	2	0 to 32	-	0x0605	1541	16-bit
P06-06	DI_2 channel logic selection	Operation setting	Effective immediately	0	0 to 1	-	0x0606	1542	16-bit
P06-07	DI_2 input source selection	Operation setting	Effective immediately	0	0 to 1	-	0x0607	1543	16-bit
P06-08	DI_3 channel function selection	Operation setting	Power-on again	3	0 to 32	-	0x0608	1544	16-bit
P06-09	DI_3 channel logic selection	Operation setting	Effective immediately	0	0 to 1	-	0x0609	1545	16-bit
P06-10	DI_3 input source selection	Operation setting	Effective immediately	0	0 to 1	-	0x060A	1546	16-bit
P06-11	DI_4 channel function selection	Operation setting	Power-on again	4	0 to 32	-	0x060B	1547	16-bit
P06-12	DI_4 channel logic selection	Operation setting	Effective immediately	0	0 to 1	-	0x060C	1548	16-bit
P06-13	DI_4 input source selection	Operation setting	Effective immediately	0	0 to 1	-	0x060D	1549	16-bit
P06-14	DI_5 channel function selection	Operation setting	Power-on again	7	0 to 32	-	0x060E	1550	16-bit
P06-15	DI_5 channel logic selection	Operation setting	Effective immediately	0	0 to 1	-	0x060F	1551	16-bit
P06-16	DI_5 input source selection	Operation setting	Effective immediately	0	0 to 1	-	0x0610	1552	16-bit
P06-17	DI_6 channel function selection	Operation setting	Power-on again	11	0 to 32	-	0x0611	1553	16-bit
P06-18	DI_6 channel logic selection	Operation setting	Effective immediately	0	0 to 1	-	0x0612	1554	16-bit
P06-19	DI_6 input source selection	Operation setting	Effective immediately	0	0 to 1	-	0x0613	1555	16-bit
P06-20	DI_7 channel function selection	Operation setting	Power-on again	0	0 to 32	-	0x0614	1556	16-bit
P06-21	DI_7 channel logic selection	Operation setting	Power-on again	0	0 to 1	-	0x0615	1557	16-bit
P06-22	DI_7 input source selection	Operation setting	Effective immediately	0	0 to 1	-	0x0616	1558	16-bit
P06-23	DI_8 channel function selection	Operation setting	Power-on again	0	0 to 32	-	0x0617	1559	16-bit
P06-24	DI_8 channel logic selection	Operation setting	Power-on again	0	0 to 1	-	0x0618	1560	16-bit
P06-25	DI_8 input source selection	Operation setting	Effective immediately	0	0 to 1	-	0x0619	1561	16-bit

(Full V1.1)

P06-26	DO_1 channel function selection	Operation setting	Effective immediately	132	128 to 148	-	0x061A	1562	16-bit
P06-27	DO_1 channel logic selection	Operation setting	Effective immediately	0	0 to 1	-	0x061B	1563	16-bit
P06-28	DO_2 channel function selection	Operation setting	Effective immediately	130	128 to 148	-	0x061C	1564	16-bit
P06-29	DO_2 channel logic selection	Operation setting	Effective immediately	0	0 to 1	-	0x061D	1565	16-bit
P06-30	DO_3 channel function selection	Operation setting	Effective immediately	129	128 to 148	-	0x061E	1566	16-bit
P06-31	DO_3 channel logic selection	Operation setting	Effective immediately	0	0 to 1	-	0x061F	1567	16-bit
P06-32	DO_4 channel function selection	Operation setting	Effective immediately	134	128 to 148	-	0x0620	1568	16-bit
P06-33	DO_4 channel logic selection	Operation setting	Effective immediately	0	0 to 1	-	0x0621	1569	16-bit

Group P07 multi-segment position

Function code	Name	Setting method	Effective time	Default	Range	Unit	Modbus address		Data type
							Hexadecimal	Decimal	
P07-01	multi-segment position operation mode	Shutdown setting	Effective immediately	0	0 to 2	-	0x0701	1793	16-bit
P07-02	Starting position number	Shutdown setting	Effective immediately	1	1 to 16	-	0x0702	1794	16-bit
P07-03	End position number	Shutdown setting	Effective immediately	1	1 to 16	-	0x0703	1795	16-bit
P07-04	Margin processing method	Shutdown setting	Effective immediately	0	0 to 1	-	0x0704	1796	16-bit
P07-05	Displacement instruction type	Shutdown setting	Effective immediately	0	0 to 1	-	0x0705	1797	16-bit
P07-06	Waiting time unit	Shutdown setting	Effective immediately	0	0 to 1	-	0x0706	1798	16-bit
P07-07	Reserved	Shutdown setting	Effective immediately	0	0 to 63355	-	0x0707	1799	16-bit
P07-08	Reserved	Shutdown setting	Effective immediately	0	0 to 0	-	0x0708	1800	16-bit
P07-09	The 1st position displacement	Operation setting	Effective immediately	10000	-2147483647 to 2147483646	-	0x0709	1801	32-bit
P07-10	Maximum speed of the 1st position displacement	Operation setting	Effective immediately	100	1 to 5000	rpm	0x070B	1803	16-bit
P07-11	Acceleration and deceleration time of the 1st position displacement	Operation setting	Effective immediately	100	1 to 65535	ms	0x070C	1804	16-bit
P07-12	Waiting time after completion of the 1st position displacement	Operation setting	Effective immediately	100	1 to 65535	Set by P07-06	0x070D	1805	16-bit
P07-13	The 2nd position displacement	Operation setting	Effective immediately	10000	-2147483647 to 2147483646	-	0x070E	1806	32-bit
P07-14	Maximum speed of the 2nd position displacement	Operation setting	Effective immediately	100	1 to 5000	rpm	0x0710	1808	16-bit
P07-15	Acceleration and deceleration time of the 2nd position displacement	Operation setting	Effective immediately	100	1 to 65535	ms	0x0711	1809	16-bit
P07-16	Waiting time after completion of the 2nd position displacement	Operation setting	Effective immediately	100	1 to 65535	Set by P07-06	0x0712	1810	16-bit
P07-17	The 3rd position displacement	Operation setting	Effective immediately	10000	-2147483647 to 2147483646	-	0x0713	1811	32-bit

P07-18	Maximum speed of the 3rd position displacement	Operation setting	Effective immediately	100	1 to 5000	rpm	0x0715	1813	16-bit
P07-19	Acceleration and deceleration time of the 3rd position displacement	Operation setting	Effective immediately	100	1 to 65535	ms	0x0716	1814	16-bit
P07-20	Waiting time after completion of the 3rd position displacement	Operation setting	Effective immediately	100	1 to 65535	Set by P07-06	0x0717	1815	16-bit
P07-21	The 4th position displacement	Operation setting	Effective immediately	10000	-2147483647 to 2147483646	-	0x0718	1816	32-bit
P07-22	Maximum speed of the 4th position displacement	Operation setting	Effective immediately	100	1 to 5000	rpm	0x071A	1818	16-bit
P07-23	Acceleration and deceleration time of the 4th position displacement	Operation setting	Effective immediately	100	1 to 65535	ms	0x071B	1819	16-bit
P07-24	Waiting time after completion of the 4th position displacement	Operation setting	Effective immediately	100	1 to 65535	Set by P07-06	0x071C	1820	16-bit
P07-25	The 5th position displacement	Operation setting	Effective immediately	10000	-2147483647 to 2147483646	-	0x071D	1821	32-bit
P07-26	Maximum speed of the 5th position displacement	Operation setting	Effective immediately	100	1 to 5000	rpm	0x071F	1823	16-bit
P07-27	Acceleration and deceleration time of the 5th position displacement	Operation setting	Effective immediately	100	1 to 65535	ms	0x0720	1824	16-bit
P07-28	Waiting time after completion of the 5th position displacement	Operation setting	Effective immediately	100	1 to 65535	Set by P07-06	0x0721	1825	16-bit
P07-29	The 6th position displacement	Operation setting	Effective immediately	10000	-2147483647 to 2147483646	-	0x0722	1826	32-bit
P07-30	Maximum speed of the 6th position displacement	Operation setting	Effective immediately	100	1 to 5000	rpm	0x0724	1828	16-bit
P07-31	Acceleration and deceleration time of the 6th position displacement	Operation setting	Effective immediately	100	1 to 65535	ms	0x0725	1829	16-bit
P07-32	Waiting time after completion of the 6th position displacement	Operation setting	Effective immediately	100	1 to 65535	Set by P07-06	0x0726	1830	16-bit

P07-33	The 7th position displacement	Operation setting	Effective immediately	10000	-2147483647 to 2147483646	-	0x0727	1831	32-bit
P07-34	Maximum speed of the 7th position displacement	Operation setting	Effective immediately	100	1 to 5000	rpm	0x0729	1833	16-bit
P07-35	Acceleration and deceleration time of the 7th position displacement	Operation setting	Effective immediately	100	1 to 65535	ms	0x072A	1834	16-bit
P07-36	Waiting time after completion of the 7th position displacement	Operation setting	Effective immediately	100	1 to 65535	Set by P07-06	0x072B	1835	16-bit
P07-37	The 8th position displacement	Operation setting	Effective immediately	10000	-2147483647 to 2147483646	-	0x072C	1836	32-bit
P07-38	Maximum speed of the 8th position displacement	Operation setting	Effective immediately	100	1 to 5000	rpm	0x072E	1838	16-bit
P07-39	Acceleration and deceleration time of the 8th position displacement	Operation setting	Effective immediately	100	1 to 65535	ms	0x072F	1839	16-bit
P07-40	Waiting time after completion of the 8th position displacement	Operation setting	Effective immediately	100	1 to 65535	Set by P07-06	0x0730	1840	16-bit
P07-41	The 9th position displacement	Operation setting	Effective immediately	10000	-2147483647 to 2147483646	-	0x0731	1841	32-bit
P07-42	Maximum speed of the 9th position displacement	Operation setting	Effective immediately	100	1 to 5000	rpm	0x0733	1843	16-bit
P07-43	Acceleration and deceleration time of the 9th position displacement	Operation setting	Effective immediately	100	1 to 65535	ms	0x0734	1844	16-bit
P07-44	Waiting time after completion of the 9th position displacement	Operation setting	Effective immediately	100	1 to 65535	Set by P07-06	0x0735	1845	16-bit
P07-45	The 10th position displacement	Operation setting	Effective immediately	10000	-2147483647 to 2147483646	-	0x0736	1846	32-bit
P07-46	Maximum speed of the 10th position displacement	Operation setting	Effective immediately	100	1 to 5000	rpm	0x0738	1848	16-bit
P07-47	Acceleration and deceleration time of the 10th position displacement	Operation setting	Effective immediately	100	1 to 65535	ms	0x0739	1849	16-bit
P07-48	Waiting time after completion of the	Operation setting	Effective immediately	100	1 to 65535	Set by P07-06	0x073A	1850	16-bit

	10th position displacement								
P07-49	The 11th position displacement	Operation setting	Effective immediately	10000	-2147483647 to 2147483646	-	0x073B	1851	32-bit
P07-50	Maximum speed of the 11th position displacement	Operation setting	Effective immediately	100	1 to 5000	rpm	0x073D	1853	16-bit
P07-51	Acceleration and deceleration time of the 11th position displacement	Operation setting	Effective immediately	100	1 to 65535	ms	0x073E	1854	16-bit
P07-52	Waiting time after completion of the 11th position displacement	Operation setting	Effective immediately	100	1 to 65535	Set by P07-06	0x073F	1855	16-bit
P07-53	The 12th position displacement	Operation setting	Effective immediately	10000	-2147483647 to 2147483646	-	0x0740	1856	32-bit
P07-54	Maximum speed of the 12th position displacement	Operation setting	Effective immediately	100	1 to 5000	rpm	0x0742	1858	16-bit
P07-55	Acceleration and deceleration time of the 12th position displacement	Operation setting	Effective immediately	100	1 to 65535	ms	0x0743	1859	16-bit
P07-56	Waiting time after completion of the 12th position displacement	Operation setting	Effective immediately	100	1 to 65535	Set by P07-06	0x0744	1860	16-bit
P07-57	The 13th position displacement	Operation setting	Effective immediately	10000	-2147483647 to 2147483646	-	0x0745	1861	32-bit
P07-58	Maximum speed of the 13th position displacement	Operation setting	Effective immediately	100	1 to 5000	rpm	0x0747	1863	16-bit
P07-59	Acceleration and deceleration time of the 13th position displacement	Operation setting	Effective immediately	100	1 to 65535	ms	0x0748	1864	16-bit
P07-60	Waiting time after completion of the 13th position displacement	Operation setting	Effective immediately	100	1 to 65535	Set by P07-06	0x0749	1865	16-bit
P07-61	The 14th position displacement	Operation setting	Effective immediately	10000	-2147483647 to 2147483646	-	0x074A	1866	32-bit
P07-62	Maximum speed of the 14th position displacement	Operation setting	Effective immediately	100	1 to 5000	rpm	0x074C	1868	16-bit
P07-63	Acceleration and deceleration time of the 14th position displacement	Operation setting	Effective immediately	100	1 to 65535	ms	0x074D	1869	16-bit

P07-64	Waiting time after completion of the 14th position displacement	Operation setting	Effective immediately	100	1 to 65535	Set by P07-06	0x074E	1870	16-bit
P07-65	The 15th position displacement	Operation setting	Effective immediately	10000	-2147483647 to 2147483646	-	0x074F	1871	32-bit
P07-66	Maximum speed of the 15th position displacement	Operation setting	Effective immediately	100	1 to 5000	rpm	0x0751	1873	16-bit
P07-67	Acceleration and deceleration time of the 15th position displacement	Operation setting	Effective immediately	100	1 to 65535	ms	0x0752	1874	16-bit
P07-68	Waiting time after completion of the 15th position displacement	Operation setting	Effective immediately	100	1 to 65535	Set by P07-06	0x0753	1875	16-bit
P07-69	The 16th position displacement	Operation setting	Effective immediately	10000	-2147483647 to 2147483646	-	0x0754	1876	32-bit
P07-70	Maximum speed of the 16th position displacement	Operation setting	Effective immediately	100	1 to 5000	rpm	0x0756	1878	16-bit
P07-71	Acceleration and deceleration time of the 16th position displacement	Operation setting	Effective immediately	100	1 to 65535	ms	0x0757	1879	16-bit
P07-72	Waiting time after completion of the 16th position displacement	Operation setting	Effective immediately	100	1 to 65535	Set by P07-06	0x0758	1880	16-bit

Group P10 Accessibility

Function code	Name	Setting method	Effective time	Default	Range	Unit	Modbus address		Data type
							Hexadecimal	Decimal	
P10-01	JOG speed	Operation setting	Effective immediately	100	0 to 3000	rpm	0x0A01	2561	16-bit
P10-02	Restore factory settings	Shutdown setting	Effective immediately	0	0 to 65535	-	0x0A02	2562	16-bit
P10-03	Fault clearing	Operation setting	Effective immediately	0	0 to 1	-	0x0A03	2563	16-bit
P10-04	Motor overload protection time factor	Operation setting	Effective immediately	100	1 to 800	%	0x0A04	2564	16-bit
P10-05	Motor model	Operation setting	Power-on again	0	0 to 65535	-	0x0A05	2565	16-bit
P10-06	Multi-turn absolute encoder reset	Shutdown setting	Effective immediately	0	0 to 1	-	0x0A06	2566	16-bit
P10-07	Set machine code manually	Operation setting	Power-on again	0	0 to 1	-	0x0A07	2567	16-bit

(Full V1.1)

P10-08	Multi-turn absolute encoder origin offset compensation	Operation setting	Effective immediately	0	-2147483647 to 2147483646	-	0x0A08	2568	32-bit
P10-11	Motor stall over-temperature enable	Operation setting	Effective immediately	0	0 to 1	-	0x0A0C	2572	16-bit

Group P12 Communication parameters

Function code	Name	Setting method	Effective time	Default	Range	Unit	Modbus address		Data type
							Hexadecimal	Decimal	
P12-01	Servo address	Operation setting	Effective immediately	1	1 to 247	-	0x0C01	3073	16-bit
P12-02	Baud rate	Operation setting	Effective immediately	2	0 to 6	-	0x0C02	3074	16-bit
P12-03	Serial data format	Operation setting	Effective immediately	0	0 to 3	-	0x0C03	3075	16-bit
P12-04	Modbus communication data is written into EEPROM	Operation setting	Effective immediately	0	0 to 1	-	0x0C04	3076	16-bit
P12-05	RS422/RS485 function selection	Operation setting	Effective immediately	0	0 to 1	-	0x0C05	3077	16-bit
P12-06	Modbus 32-bit variable high and low byte order	Operation setting	Effective immediately	0	0 to 1	-	0x0C06	3078	16-bit

Group P13 Virtual input terminal

Function code	Name	Setting method	Effective time	Default	Range	Unit	Modbus address		Data type
							Hexadecimal	Decimal	
P13-01	Virtual VDI_1 input value	Operation setting	Effective immediately	0	0 to 1	-	0x0D01	3329	16-bit
P13-02	Virtual VDI_2 input value	Operation setting	Effective immediately	0	0 to 1	-	0x0D02	3330	16-bit
P13-03	Virtual VDI_3 input value	Operation setting	Effective immediately	0	0 to 1	-	0x0D03	3331	16-bit
P13-04	Virtual VDI_4 input value	Operation setting	Effective immediately	0	0 to 1	-	0x0D04	3332	16-bit
P13-05	Virtual VDI_5 input value	Operation setting	Effective immediately	0	0 to 1	-	0x0D05	3333	16-bit
P13-06	Virtual VDI_6 input value	Operation setting	Effective immediately	0	0 to 1	-	0x0D06	3334	16-bit
P13-07	Virtual VDI_7 input value	Operation setting	Effective immediately	0	0 to 1	-	0x0D07	3335	16-bit
P13-08	Virtual VDI_8 input value	Operation setting	Effective immediately	0	0 to 1	-	0x0D08	3336	16-bit
P13-11	Virtual VDO_1 input value	Operation setting	Effective immediately	0	0 to 1	-	0x0D0B	3339	16-bit
P13-12	Virtual VDO_2 input value	Operation setting	Effective immediately	0	0 to 1	-	0x0D0C	3340	16-bit
P13-13	Virtual VDO_3 input value	Operation setting	Effective immediately	0	0 to 1	-	0x0D0D	3341	16-bit
P13-14	Virtual VDO_4 input value	Operation setting	Effective immediately	0	0 to 1	-	0x0D0E	3342	16-bit

DI/DO channel function definition

DI channel function definition			
No.	Name	Function name	Content
0	--	Off (not used)	-
1	S-ON	Servo enable	Invalid DI port logic: Servo motor enable prohibited Valid DI port logic: Servo motor is enabled
2	A-CLR	Fault and warning clear	Invalid DI port logic: No reset fault or warning Valid DI port logic: Reset fault or warning
3	POT	Forward drive prohibition	Invalid DI port logic: Forward drive allowed Valid DI port logic: Forward drive Prohibited
4	NOT	Reverse drive prohibition	Invalid DI port logic: Reverse drive allowed Valid DI port logic: Reverse drive Prohibited
5	ZCLAMP	Zero-speed clamp	Invalid DI port logic: Zero-speed clamp prohibited Valid DI port logic: Zero-speed clamp enabled
6	CL	Clear deviation counter	Invalid DI port logic: Position deviation is not clear Valid DI port logic: Position deviation is clear
7	C-SIGN	Instruction is reversed	Invalid DI port logic: default instruction direction Valid DI port logic: Reverse direction of instruction
8	E-STOP	Emergency stop	Invalid DI port logic: Position lock after zero speed stop Valid DI port logic: Current running status is not affected
9	GEAR-SEL	Electronic Gear Switch 1	Invalid DI port logic: electronic Gear Switch 1 Valid DI port logic: electronic Gear Switch 2
10	GAIN-SEL	Gain switch	-
11	INH	Instruction pulse input prohibited	Invalid DI port logic: Instruction pulse input allowed Valid DI port logic: Instruction pulse input prohibited
12	VSSEL	Vibration control input switching	-
13	INSPD1	Internal speed instruction selection 1	Constitutes an internal multi-segment speed running segment number
14	INSPD2	Internal speed instruction selection 2	Constitutes an internal multi-segment speed running segment number
15	INSPD3	Internal speed instruction selection 3	Constitutes an internal multi-segment speed running segment number
16	J-SEL	Inertia ratio switch (not implemented yet)	-
17	MixModeSel	MixModeSel Mix mode selection	Invalid DI port logic: Current running is not affected Valid DI port logic: Servo motor is in mix control mode
18	None	None	-
19	None	None	-
20	ENINPOS	Internal multi-segment enable signal	Invalid DI port logic: Current running is not affected Valid DI port logic: Servo motor runs multi-segment position
21	INPOS1	Internal multi-segment position selection 1	Constitutes an internal multi-segment position running segment number
22	INPOS2	Internal multi-segment position selection 2	Constitutes an internal multi-segment position running segment number
23	INPOS3	Internal multi-segment position selection 3	Constitutes an internal multi-segment position running segment number
24	INPOS4	Internal multi-segment position selection 4	Constitutes an internal multi-segment position running segment number

DO channel function definition			
No.	Name	Function name	Content
128	--	OFF (not used)	-
129	RDY	Servo is ready	Servo is ready, and could receive S-ON signal. Invalid DO port logic: Servo is not ready Valid DO port logic: Servo is ready
130	ALM	Fault signal	Valid when the fault is detected
131	WARN	Warning signal	Valid when warning signals are output
132	TGON	Rotation detection	When the absolute value of servo motor speed is higher than P05-16 set value: Invalid DO port logic: invalid motor rotation detection signal Valid DO port logic: valid motor rotation detection signal
133	ZSP	Zero speed signal	The signal output by the servo motor when it stops: Invalid DO port logic: invalid motor zero-speed signal Valid DO port logic: valid motor zero-speed signal
134	P-COIN	Positioning complete	Output this signal indicates that the servo drive positioning is complete
135	P-NEAR	Positioning approach	Output this signal indicates that the servo drive positioning is approach
136	V-COIN	Consistent speed	In speed mode, when the absolute value of the difference between motor speed and speed instruction is less than the set value of P05-17, the signal is valid
137	V-NEAR	Speed approach	Invalid DO port logic: The absolute value of motor speed feedback after filtering is greater than the set value of P05-18 Valid DO port logic: The absolute value of motor speed feedback after filtering is less than the set value of P05-18
138	T-COIN	Torque arrival	Invalid DO port logic: The absolute value of torque instruction is greater than the set value. Valid DO port logic: The absolute value of torque instruction reaches the set value.
139	T-LIMIT	Torque limit	The confirmation signal of torque limit. Invalid DO port logic: The torque of motor is not limited Valid DO port logic: The torque of motor is limited
140	V-LIMIT	Speed limited	The confirmation signal of speed limit in torque mode. Invalid DO port logic: The motor speed is not limited Valid DO port logic: The motor speed is limited
141	BRK-OFF	Brake output	Output brake signal Invalid DO port logic: The brake device does not operate Valid DO port logic: The brake device operates
142	SRV-ST	Servo on state output	Invalid DO port logic: Servo motor is not operate Valid DO port logic: Servo motor is in operation
143	VD2A VD2B	None	-
	VD2F	OZ	Z pulse output The output signal indicates that servo drive rotates 1 turn
144	None	-	-
145	COM_VDO1	Communication VDO1 output	Use communication VDO
146	COM_VDO2	Communication VDO2 output	Use communication VDO
147	COM_VDO3	Communication VDO3 output	Use communication VDO
148	COM_VDO4	Communication VDO4 output	Use communication VDO

Group U0 Monitoring parameters

Function code	Name	Category	Unit	Modbus address		Data type
				Hexadecimal	Decimal	
U0-01	Servo Status	Universal	-	0x1E01	7681	16-bit
U0-02	Servo motor speed	Universal	rpm	0x1E02	7682	16-bit
U0-03	Input speed instruction	Universal	rpm	0x1E03	7683	16-bit
U0-04	Corresponding speed of position instruction	Universal	rpm	0x1E04	7684	16-bit
U0-05	Pulse deviation	Universal	Equivalent pulse unit	0x1E05	7685	32-bit
U0-06	Reserved	Universal	-	0x1E07	7687	16-bit
U0-07	Reserved	Universal	-	0x1E08	7688	16-bit
U0-08	Input instruction pulse frequency	Universal	kHz	0x1E09	7689	16-bit
U0-09	Input instruction pulse number (lower 32 bits)	Universal	Instruction unit	0x1E0A	7690	32-bit
U0-10	Reserved	Universal	Instruction unit	0x1E0C	7692	16-bit
U0-11	Reserved	Universal	Instruction unit	0x1E0D	7693	32-bit
U0-12	Real-time torque monitoring	Universal	0.1%	0x1E0F	7695	16-bit
U0-13	Encoder cumulative position (lower 32 bits)	Universal	Encoder unit	0x1E10	7696	32-bit
U0-14	Reserved	Universal	Encoder unit	0x1E12	7698	16-bit
U0-15	Encoder cumulative position (high 32 bits)	Universal	Encoder unit	0x1E13	7699	32-bit
U0-16	Reserved	Universal	Encoder unit	0x1E15	7701	16-bit
U0-17	DI input signal status	Universal	-	0x1E16	7702	16-bit
U0-18	Reserved	Universal	-	0x1E17	7703	16-bit
U0-19	DO output signal status	Universal	-	0x1E18	7704	16-bit
U0-20	Real-time load inertia ratio	Universal	%	0x1E19	7705	16-bit
U0-21	AI1 input voltage value Reserved*	Universal	V	0x1E1A	7706	16-bit
U0-22	AI2 input voltage value Reserved*	Universal	V	0x1E1B	7707	16-bit
U0-23	Vibration Frequency	Universal	Hz	0x1E1C	7708	16-bit
U0-24	Vibration Amplitude	Universal	rpm	0x1E1D	7709	16-bit
U0-25	Forward torque limit value	Universal	%	0x1E1E	7710	16-bit
U0-26	Reverse torque limit value	Universal	%	0x1E1F	7711	16-bit
U0-27	Forward speed limit value	Universal	rpm	0x1E20	7712	16-bit
U0-28	Reverse speed limit value	Universal	rpm	0x1E21	7713	16-bit
U0-29	Mechanical angle	Universal	°	0x1E22	7714	16-bit
U0-30	Electrical angle	Universal	°	0x1E23	7715	16-bit
U0-31	Bus voltage	Universal	V	0x1E24	7716	16-bit
U0-32	Radiator temperature	Universal	°C	0x1E25	7717	16-bit
U0-33	Instantaneous output power	Universal	W	0x1E26	7718	16-bit
U0-34	Average output power	Universal	W	0x1E27	7719	16-bit
U0-35	Total operation time (hour)	Universal	h	0x1E28	7720	16-bit
U0-36	Reserved	Universal	-	0x1E29	7721	16-bit
U0-37	Total operation time (minute)	Universal	min	0x1E2A	7722	16-bit
U0-38	Total operation time (second)	Universal	s	0x1E2B	7723	16-bit

(Full V1.1)

U0-39	Load torque percentage	Universal	%	0x1E2C	7724	16-bit
U0-40	Current operation time (hour)	Universal	h	0x1E2D	7725	16-bit
U0-41	Reserved	-	-	0x1E2E	7726	16-bit
U0-42	Current operation time (minute)	Universal	min	0x1E2F	7727	16-bit
U0-43	Current operation time (second)	Universal	s	0x1E30	7728	16-bit
U0-44	Instantaneous braking resistor power	Universal	W	0x1E31	7729	16-bit
U0-45	Reserved	-	-	0x1E32	7730	16-bit
U0-46	Average braking resistor power	Universal	W	0x1E33	7731	16-bit
U0-47	Reserved	Universal	-	0x1E34	7732	16-bit
U0-48	Power-on times	Universal	Times	0x1E35	7733	16-bit
U0-49	Reserved	-	-	0x1E36	7734	16-bit
U0-50	Motor cumulative number of turns (low 32 bits)	Universal	Circle	0x1E37	7735	32-bit
U0-51	Motor cumulative number of turns (high 32 bits)	Universal	Circle	0x1E39	7737	32-bit
U0-52	Reserved	Universal	-	0x1E3B	7739	16-bit
U0-53	Motor model code	Universal	-	0x1E3C	7740	16-bit
U0-54	Absolute encoder position in 1 circle	Universal	Encoder unit	0x1E3D	7741	32-bit
U0-55	Circle numbers of multi-turn absolute encoder	Universal	Circle	0x1E3F	7743	16-bit
U0-56	Current position of the multi-turn absolute encoder	Universal	Instruction unit	0x1E41	7745	32-bit

Group U1 Warning monitoring

Function code	Name	Category	Unit	Modbus address		Data type
				Hexadecimal	Decimal	
U1-01	Current fault code	Warning	-	0x1F01	7937	16-bit
U1-02	Current warning code	Warning	-	0x1F02	7938	16-bit
U1-03	U phase current when faults occur	Warning	A	0x1F03	7939	16-bit
U1-04	V phase current when faults occur	Warning	A	0x1F04	7940	16-bit
U1-05	Bus voltage when faults occur	Warning	V	0x1F05	7941	16-bit
U1-06	IGBT temperature when faults occur	Warning	°C	0x1F06	7942	16-bit
U1-07	Torque component when faults occur	Warning	%	0x1F07	7943	16-bit
U1-08	Excitation component when faults occur	Warning	%	0x1F08	7944	16-bit
U1-09	Position deviation when faults occur	Warning	Encoder unit	0x1F09	7945	32-bit
U1-10	Speed value when faults occur	Warning	rpm	0x1F0B	7947	16-bit
U1-11	Time when the fault occurred	Warning	s	0x1F0C	7948	16-bit
U1-12	Number of faults in this operation	Warning	-	0x1F0D	7949	16-bit
U1-13	Number of warnings in this operation	Warning	-	0x1F0E	7950	16-bit
U1-14	Total number of historical faults	Warning	-	0x1F0F	7951	16-bit
U1-15	Total number of historical warnings	Warning	-	0x1F10	7952	16-bit
U1-16	The 1st fault code of the most recent	Warning	-	0x1F11	7953	16-bit
U1-17	The 2nd fault code of the most recent	Warning	-	0x1F12	7954	16-bit
U1-18	The 3rd fault code of the most recent	Warning	-	0x1F13	7955	16-bit
U1-19	The 4th fault code of the most recent	Warning	-	0x1F14	7956	16-bit
U1-20	The 5th fault code of the most recent	Warning	-	0x1F15	7957	16-bit
U1-21	The 1st warning code of the most recent	Warning	-	0x1F16	7958	16-bit
U1-22	The 2nd warning code of the most recent	Warning	-	0x1F17	7959	16-bit
U1-23	The 3rd warning code of the most recent	Warning	-	0x1F18	7960	16-bit

U1-24	The 4th warning code of the most recent	Warning	-	0x1F19	7961	16-bit
U1-25	The 5th warning code of the most recent	Warning	-	0x1F1A	7962	16-bit

Group U2 Device monitoring

Function code	Name	Category	Unit	Modbus address		Data type
				Hexadecimal	Decimal	
U2-01	Product Series	Device	-	0x2001	8193	16-bit
U2-02	Model	Device	-	0x2002	8194	16-bit
U2-03	Model	Device	-	0x2003	8195	16-bit
U2-04	Firmware version	Device	-	0x2004	8196	16-bit
U2-05	FPGA version	Device	-	0x2005	8197	16-bit
U2-06	Firmware day (year)	Device	Year	0x2006	8198	16-bit
U2-07	Firmware day (month)	Device	Month	0x2007	8199	16-bit
U2-08	Firmware day (day)	Device	Day	0x2008	8200	16-bit
U2-09	Device serial number 1	Device	-	0x2009	8201	16-bit
U2-10	Device serial number 2	Device	-	0x200A	8202	16-bit
U2-11	Device serial number 3	Device	-	0x200B	8203	16-bit
U2-12	Device serial number 4	Device	-	0x200C	8204	16-bit
U2-13	Device serial number 5	Device	-	0x200D	8205	16-bit
U2-14	Device serial number 6	Device	-	0x200E	8206	16-bit
U2-15	Device serial number 7	Device	-	0x200F	8207	16-bit
U2-16	Device serial number 8	Device	-	0x2010	8208	16-bit

11.2 List of fault and warning codes

Code	Content	Clearable	Stop immediately
Er.01	Parameter damage		○
Er.02	Parameter storage error		○
Er.03	ADC reference source error		○
Er.04	AD current sampling conversion error		○
Er.05	FPGA communication exception		○
Er.06	FPGA incorrect program version		○
Er.07	Clock exception		○
Er.20	Overcurrent		○
Er.21	Main power supply is undervoltage	✓	○
Er.22	Main power supply is overvoltage	✓	○
Er.23	Braking resistor is not connected	✓	○
Er.24	Braking resistor is abnormal		○
Er.25	Braking resistor resistance is too large	✓	○
Er.26	Wrong motor model		○
Er.27	Encoder is disconnected	✓	○
Er.28	Encoder Z pulse is lost		○
Er.29	The incremental encoder AB count does not equal to the number of encoder lines multiply by 4		○
Er.30	Encoder UVW signal error		○
Er.31	The power line is disconnected	✓	○
Er.32	Exceeding the maximum speed of motor		○
Er.33	The power module is over temperature	✓	○
Er.34	Motor overload protection	✓	○
Er.35	Electronic gear ratio exceeds the limit	✓	○

Er.36	Position deviation is too large	✓	○
Er.37	Torque saturation is abnormal	✓	○
Er.38	The main circuit is electrically deficient	✓	○
Er.39	Emergency stop	✓	○
Er.40	Encoder battery failure	✓	○
Er.41	Motor (encoder) over temperature	✓	○
Er.42	Encoder write failure	✓	○
Er.60	ADC conversion is incomplete		○
Er.61	Internal software fault		○
Er.62	Internal software fault		○
Er.63	Internal software fault		○
Er.64	Internal software fault		○
Er.65	Internal software fault		○
A-81	Over speed alarm	✓	
A-82	Overload	✓	
A-83	Braking resistor is over temperature or overload	✓	
A-84	Parameter modification that needs to be powered on again	✓	
A-85	Receive position pulse when servo is OFF	✓	
A-86	Input pulse frequency is too high	✓	
A-88	Main circuit momentary is power off	✓	
A-89	DI port configuration is duplicate	✓	
A-90	DO port configuration is duplicate	✓	
A-91	Parameter modification is too frequent	✓	
A-92	low encoder battery voltage warning	✓	
A-93	Encoder read and write check abnormal and frequency is too high	✓	

Clearable: The panel can be stopped displaying the status by giving a "clear signal"

Stop immediately: The control action state stops immediately.

11.3 Wire

Wire model	Wire length	Wire exterior
P-Z301-R4M-3MX4	3m	<p>Suitable for VD2A drive connecting 60/80 flange lead wire motor</p>
P-Z301-R4M-5MX4	5m	
P-Z301-R4M-10MX4	10m	
P-U301-R4M-3MX4	3m	<p>Suitable for VD2B drive connecting 80 flange lead wire motor</p>
P-U301-R4M-5MX4	5m	
P-U301-R4M-10MX4	10m	

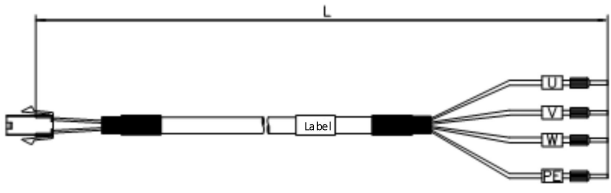
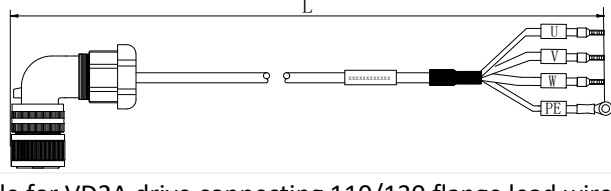
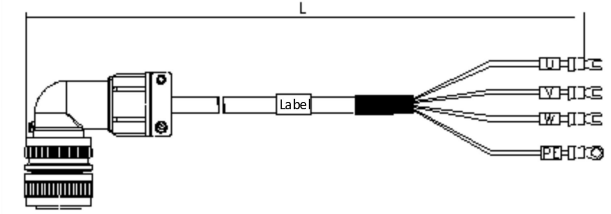
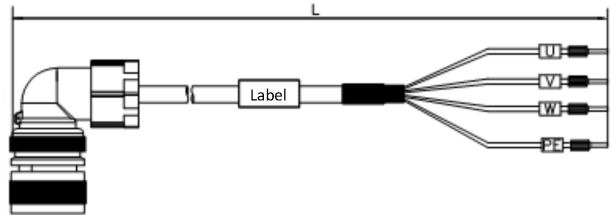
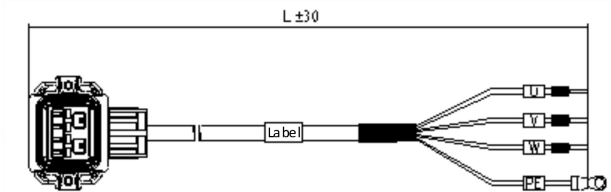
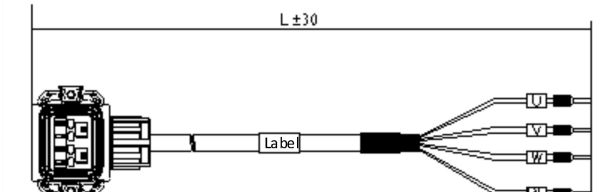
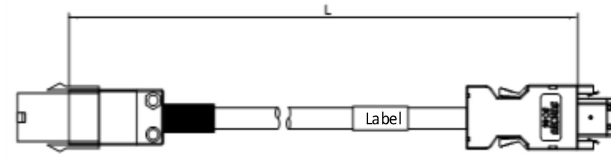
P-Z4-R4M-3MX4	3m	 <p>Suitable for VD2F drive connecting 40/60/80 flange lead wire motor</p>
P-Z4-R4M-5MX4	5m	
P-Z4-R4M-10MX4	10m	
P-Z3O1-H28J4M-3MX4	3m	 <p>Suitable for VD2A drive connecting 110/130 flange lead wire motor</p>
P-Z3O1-H28J4M-5MX4	5m	
P-Z3O1-H28J4M-10MX4	10m	
P-U3O1-H28J4M-3MX4	3m	 <p>Suitable for VD2B drive connecting 110/130 flange lead wire motor</p>
P-U3O1-H28J4M-5MX4	5m	
P-U3O1-H28J4M-10MX4	10m	
P-Z4-H28J4M-3MX4	3m	 <p>Suitable for VD2F drive connecting 110/130 flange lead wire motor</p>
P-Z4-H28J4M-5MX4	5m	
P-Z4-H28J4M-10MX4	10m	
P-Z3O1-MC4S-3MX4	3m	 <p>Suitable for VD2A drive connecting 60/80 flange lead wire motor</p>
P-Z3O1-MC4S-5MX4	5m	
P-Z3O1-MC4S-10MX4	10m	
P-Z4-MC4S-3MX4	3m	 <p>Suitable for VD2F drive connecting 60/80 flange lead wire motor</p>
P-Z4-MC4S-5MX4	5m	
P-Z4-MC4S-10MX4	10m	

Table 11-1 Servo motor power cable exterior diagram

Wire model	Wire length	Wire exterior
E-J1394-R9M-3MX5-A	3m	 <p>Suitable for VD2/VD2F drives connecting 40/60/80 flange lead wire motor (single-turn encoder)</p>
E-J1394-R9M-5MX5-A	5m	
E-J1394-R9M-10MX5-A	10m	

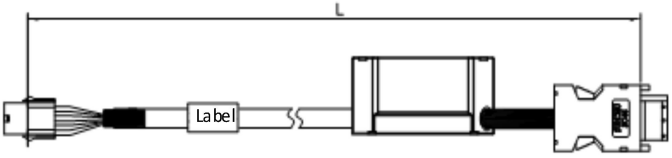
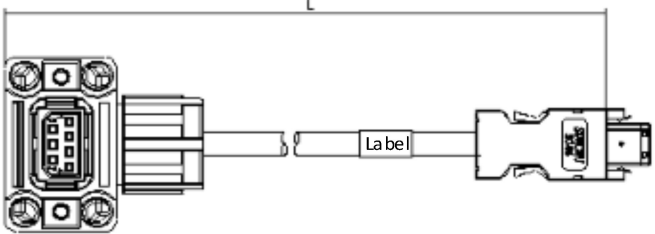
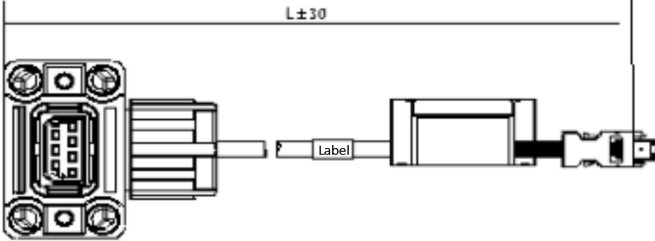
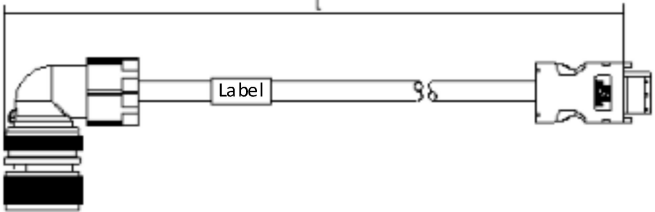
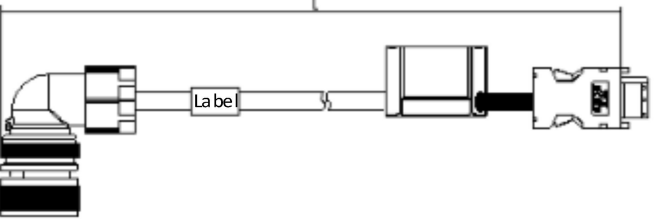
E-J1394-R9M-3MX7-A1	3m	
E-J1394-R9M-5MX7-A1	5m	
E-J1394-R9M-10MX7-A1	10m	
E-J1394-MC7S-3MX5-A	3m	
E-J1394-MC7S-5MX5-A	5m	
E-J1394-MC7S-10MX5-A	10m	
E-J1394-MC7S-3MX7-A1	3m	
E-J1394-MC7S-5MX7-A1	5m	
E-J1394-MC7S-10MX7-A1	10m	
E-J1394-H28K7M-3MX5-A	3m	
E-J1394-H28K7M-5MX5-A	5m	
E-J1394-H28K7M-10MX5-A	10m	
E-J1394-H28K7M-3MX7-A1	3m	
E-J1394-H28K7M-5MX7-A1	5m	
E-J1394-H28K7M-10MX7-A1	10m	

Table 11-2 Servo encoder power cable exterior diagram